



**VersaNail**  
**Humeral Proximal**  
Nailing System

**Sales Sheet**

**BIOMET**

# VersaNail Humeral Proximal Nailing System

## Features and Benefits

DESIGNED to treat proximal fractures, unique locking capabilities,  
SIMPLIFIED push-button release, ADJUSTABLE targeting device.

## Nail Specifications, Nail Size and Screw Chart

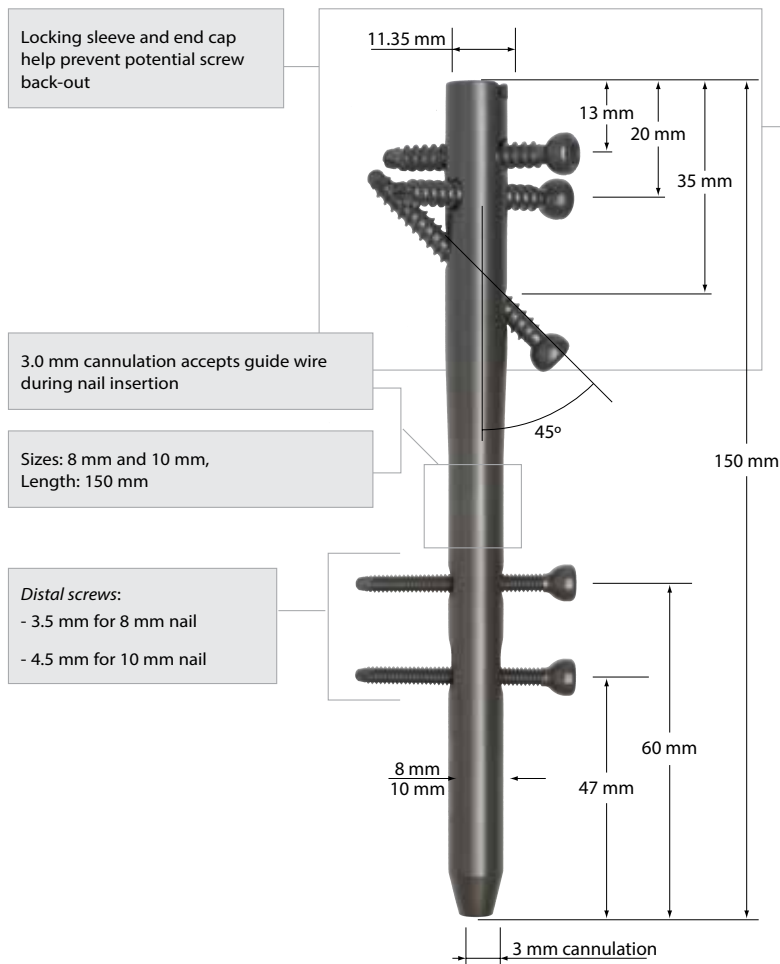

**Proximal screws:**

- Unique proximal screw configuration enhances fragment fixation
- 4.8 mm for 8 mm and 10 mm nails
- 2 L-M transverse screws: 30 degrees from oblique screw
- 1 L-M oblique screw: 45 degrees

## Implant Offering

Proximal Nail Diameters: 8 mm and 10 mm Nail Length: 150 mm Nail packaged complete with End Cap (Sterile)		
Cat. No.	Diameter (mm)	Length (mm)
1818-08-015	8	150
1818-10-015	10	150
Proximal Screws (Non-sterile)		
1819-48-030 to 1819-48-076	4.8 Cancellous	30 - 76
Proximal Screws (Sterile)		
1818-48-030 to 1818-48-076	4.8 Cancellous	30 - 76
Distal Screws (Non-sterile)		
1819-35-020 to 1819-35-040	3.5 Cortical	20 - 40
14022-20 to 14022-70	4.5 Cortical	20 - 70
Distal Screws (Sterile)		
1818-35-020 to 1818-35-040	3.5 Cortical	20 - 40
8050-45-020 to 8050-45-070	4.5 Cortical	20 - 70

This material is intended for health care professionals and the Biomet sales force only. Distribution to any other recipient is prohibited. All content herein is protected by copyright, trademarks and other intellectual property rights owned by or licensed to Biomet Inc. or its affiliates unless otherwise indicated. This material must not be redistributed, duplicated or disclosed, in whole or in part, without the express written consent of Biomet.

Check for country product clearances and reference product specific instructions for use. For complete product information, including indications, contraindications, warnings, precautions, and potential adverse effects, see the package insert and Biomet's website.

Not for distribution in France.

**BIOMET**  
TRAUMA

One Surgeon. One Patient.

©2014 Biomet Trauma • Form No. BMET0084.0-GBL • REV0614

**Legal Manufacturer**  
Biomet Trauma  
56 East Bell Drive  
P.O. Box 587  
Warsaw, Indiana 46581  
USA

[www.biomet.com](http://www.biomet.com)

**EC REP** **Authorised Representative**  
Biomet UK Ltd.  
Waterton Industrial Estate  
Bridgend, South Wales  
CF31 3XA  
UK