



# Zimmer® Natural Nail® System

Cephalomedullary Nail  
Surgical Technique

STANDARD





**Zimmer Natural Nail  
System Cephalomedullary  
Nail Surgical Technique -  
Standard**

<b>Table of Contents</b>	
<b>Product Overview</b>	<b>2</b>
<b>Implant Overview</b>	<b>2</b>
<b>Indications</b>	<b>2</b>
<b>Contraindications</b>	<b>2</b>
<b>Surgical Technique</b>	<b>2</b>
Preoperative Planning	2
Patient Positioning	2
Reduction	3
Starting Point Location	3
Proximal Reaming	4
Shaft Reaming	5
Implant Selection	5
Nail Assembly and Insertion	5
Lag Screw Placement	7
Distal Targeting For Short Nails	10
Freehand Technique for Long Nails	11
Final Implant Placement	11
Postoperative Care	11
Nail Extraction	11
<b>Cephalomedullary Long Nail Details</b>	<b>13</b>
<b>Cephalomedullary Short Nail Details</b>	<b>14</b>
<b>Product Information</b>	<b>15</b>

## Product Overview

The *Zimmer Natural Nail System* is a system of intramedullary nails, screws, instruments and other associated implants that are designed to provide stable internal fixation for fractured long bones. The nails have been designed for specific applications to help restore the shape of the fractured bone to its natural, pre-injured state.

The Cephalomedullary Nail was designed to help treat fractures of the femur, especially intertrochanteric and subtrochanteric fractures. The nail features a small proximal section that is designed to minimize the amount of bone that must be removed for nail insertion. A lag screw is placed through the nail into the femoral head to secure the nail in place proximally and help control the different segments of the bone while healing occurs. Screws are placed through the nail distally to further secure the implant in place and maintain length and alignment while healing occurs.

A choice of short and long nails, as well as nails of different diameters and center-column-diaphyseal (CCD) angles are available to best match the individual anatomy of the patient.

## Implant Overview

Nail Diameters: 10, 11.5, 13, 14.5 (14.5 is available only for short nails)

Nail Lengths: 21.5cm (short), 30 to 48cm in 2cm increments

CCD Angles: 125°, 130°, 135°

Lag Screw Diameter: 10.5mm

Lag Screw Lengths: 70 to 130mm in 5mm increments

Distal Screw Diameter: 5.0mm

Distal Screw Lengths: 20 to 60mm in 2.5mm increments, 65 to 100mm in 5mm increments

Distal Screws available in fully- and partially-threaded configurations

Materials: Ti-6Al-4V alloy

Precision instrumentation is provided to help implant the nail. Many of the instruments and implants feature a color coding system to help the surgical team use the system. Certain instruments are not color coded. The color coding system is referenced in the technique. A wall chart (97-2493-003-00) is also available to help explain the color coding system.

## Indications

The *Zimmer Natural Nail System* is intended for temporary fracture fixation and stabilization of the bone.

Indications for the Cephalomedullary nails include:

- Compound and simple shaft fractures
- Proximal, metaphyseal and distal shaft fractures
- Segmental fractures
- Comminuted fractures
- Fractures involving osteopenic and osteoporotic bone
- Pathological fractures
- Fractures with bone loss
- Pseudoarthrosis, non-union, mal-union and delayed union
- Periprosthetic fractures
- Surgically created defects such as osteotomies
- Intertrochanteric and subtrochanteric fractures

## Contraindications

- A medullary canal obliterated by a previous fracture or tumor
- Bone shaft having excessive bow or deformity
- Lack of bone substance or bone quality, which makes stable seating of the implant impossible
- All concomitant diseases that can impair the functioning and the success of the implant
- Infection
- Insufficient blood circulation
- Skeletally immature patients

**WARNING: This nail should only be used to treat a periprosthetic fracture if the in situ device is firmly fixed. When treating a periprosthetic fracture, the nail should be positioned so that it does not come in contact with the in situ device.**

## Surgical Technique

### Preoperative Planning

Preoperative planning is recommended before beginning the surgical procedure. An A/P and Lateral x-ray of the injured femur should be taken preoperatively and evaluated for length, canal size and implant suitability. A/P and Lateral x-rays of the contralateral uninjured femur can also be taken preoperatively to provide insight into the characteristics of the pre-injured femur.

## Patient Positioning

Patients can be positioned either supine or in a lateral decubitus position. As the C-arm will be used during the procedure, care should be taken to orient the patient to allow for A/P and Lateral imaging of the proximal femur, the fracture and the distal femur. The use of a fracture table can be beneficial in helping to reduce fractures as well as to facilitate intraoperative imaging with a C-arm. The patient should be positioned to allow for easy access to the greater trochanter of the femur with instrumentation. Adduction of the affected leg can also be helpful, especially in the supine position.

Drape the patient appropriately to allow the surgeon to work around the hip and full length of the femur (to the knee).

## Reduction

It is critical to achieve anatomic reduction before beginning any of the steps to place the intramedullary nail. Traction should be used as necessary to help achieve fracture reduction. Several instruments are available to assist in fracture reduction including clamps, ball spike pushers and Steinmann pins.

## Starting Point Location

Palpate the greater trochanter manually. Incise the skin starting about 2 cm proximal to the tip of the greater trochanter and extending proximally 2 to 3 cm. Dissect through the tissues splitting the fascia lata down to the bone. Assemble the STARTING POINT LOCATOR inside the ENTRY CANNULA. Place the tip of the STARTING POINT LOCATOR through the incision down to the tip of the greater trochanter (Fig. 1).

In large patients and/or when using the standard guide, a more proximal incision may be appropriate.



Fig. 1

Place the 3.0mm PIN through the center hole of the STARTING POINT LOCATOR. Use the C-arm to visualize the pin's position from an A/P and Lateral view. The pin should be inserted at the tip of the greater trochanter in the posterior portion of the middle third of the trochanter. The pin should not be on the lateral portion of the greater trochanter, it must be on the tip. A starting point slightly medial to the tip of the trochanter is also acceptable.

**NOTE: A starting point lateral to the tip of the greater trochanter may lead to a varus reduction following nail insertion.**

If necessary, remove the pin and move it into the hole in the STARTING POINT LOCATOR that will align the pin correctly with the tip of the greater trochanter.

Drive the pin through the tip of the greater trochanter down to the level of the lesser trochanter. Remove the STARTING POINT LOCATOR from the ENTRY CANNULA. Use the 8mm ENTRY REAMER to ream an entry portal into the proximal femur through the starting point on the tip of the greater trochanter (Fig 2). Remove the reamer and 3.0mm pin.

Alternatively, a CANNULATED AWL can be used to find the entry point and create the entry portal (Fig. 3). Widening of the fracture side and varus tilting of the proximal fragment should be avoided.



Fig. 2



Fig. 3

Place a 3.0mm x 100cm BALL TIP GUIDE WIRE or TEAR DROP GUIDE WIRE through the ENTRY CANNULA, all the way into the distal femur (Fig. 4). To aid in manipulation, bend the tip of the GUIDE WIRE at about a 10° angle 5cm from the end.

**CAUTION: If the GUIDE WIRE is bent shorter than 5cm from the end of the wire and/or more than 10 degrees it may be difficult to remove from the nail. If the wire becomes lodged inside the nail, utilize the GUIDE WIRE GRIPPER and mallet to remove the guide wire from the nail.**

If you plan to ream the canal of the femur, the GUIDE WIRE should be embedded in the distal femur at the level of the distal epiphyseal scar using the GUIDE WIRE GRIPPER and a MALLET (Fig. 5). Care should be taken not to drive the wire through the knee joint.



Fig. 4

A REDUCTION FINGER is included in the set. The ball tip guide wire can be fed retrograde through the REDUCTION FINGER. The REDUCTION FINGER can then be placed into the femur and used to help reduce the femur from the inside as well as to help facilitate passage of the guide wire past the fracture site.

If a LONG NAIL is to be implanted, assemble the Two Piece NAIL LENGTH GAUGE. This step can be skipped if using a short nail (21.5cm in length). Slide the tube portion of the gauge over the 3.0mm x 100cm GUIDE WIRE until the tip of the tube is at the level of the tip of the greater trochanter (confirm position using fluoroscopy) (Fig. 6). The proximal end of the GUIDE WIRE indicates the length of the wire in the canal. When determining nail length, consideration should be taken as to how deep the nail will be inserted into the femur based upon the shape of the patient's proximal femur. A RULER is also included in the set which can be used to radiographically determine nail length.

### Proximal Reaming

Use the 15.5mm TAPERED REAMER (BLUE) to prepare the proximal femur for the proximal portion of the nail (Fig. 7). The C-arm should be used to visualize the depth of the reamer in the proximal femur. Care should be taken to keep the reamer in line with the shaft of the femur to avoid reaming through the cortex of the femur.

The 15.5mm TAPERED REAMER has three grooves on it. The most proximal groove

indicates the final position of the top of the nail. The two distal grooves help visualize the placement of the lag screw. Visualizing a line between these grooves on each side of the reamer (under fluoroscopic visualization) will indicate where a 130° CCD angle lag screw would be placed in the femoral neck and head.

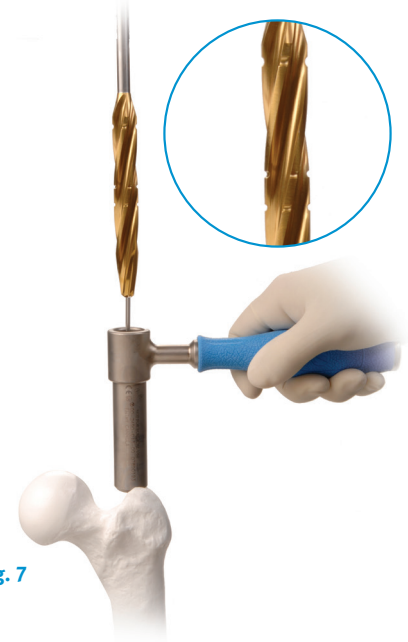

Fig. 7



Fig. 5



Fig. 6

A CHANNEL REAMER is also available for proximal reaming. The INNER CHANNEL REAMER is placed inside the 14.5mm CHANNEL REAMER SLEEVE and secured by twisting the connector. The CHANNEL REAMER is then advanced over the GUIDE WIRE through the greater trochanter. Advance the reamer to level of the lesser trochanter (Fig. 8), or deep enough to accommodate the proximal body of the nail.

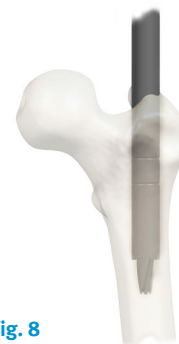

Fig. 8



After reaming to the proper depth, the INNER CHANNEL REAMER is removed by disengaging the connector and pulling the INNER CHANNEL REAMER out of the surgical field (Fig.9). The CHANNEL REAMER SLEEVE can be left in place to act as a tissue protection sleeve during shaft reaming for shaft reamers up to 13mm in diameter. To achieve greater reaming depth or diameter, the ENTRY CANNULA can be used in place of the sleeve. To facilitate reamer removal via the sleeve, power the reamer until it enters the sleeve. Following shaft reaming the CHANNEL REAMER SLEEVE should be removed from the surgical field (Fig.10).



Fig. 9

Fig. 10

### Shaft Reaming

Reaming should be performed through the ENTRY CANNULA. To reduce the risk of enlarging the entry hole laterally, push the ENTRY CANNULA medially. Start with a small reamer. Increase the diameter of the reamer by 0.5 - 1.0mm depending on the amount of resistance felt while reaming. (Fig. 11). When cortical chatter occurs, stop



Fig. 11

reaming. Choose a nail that is 1.5 - 2.0mm smaller than the last reamer used. If a short nail is to be used, it is only necessary to ream the proximal 21.5cm of the canal. If a long nail is planned, ream the full length of the canal. The GUIDE WIRE PUSHER can help prevent the GUIDE WIRE from coming out of the femur during reaming.

**NOTE: If the GUIDE WIRE becomes lodged within the reamer, use the GUIDE WIRE PUSHER to push the GUIDE WIRE back into the IM canal.**

### Implant Selection

The diameter and length of the nail have already been determined (using nail length gauge and last size of reamer utilized). Visualizing the reduced femur and/or the contralateral femur, determine which CCD angle is appropriate for the patient.

### Nail Assembly and Insertion

The color code for the cephalomedullary nail is BLUE. Ti-6Al-4V alloy nails, the TARGETING GUIDE and the CONNECTING BOLT all have blue colors on them, as well as the word BLUE on them.

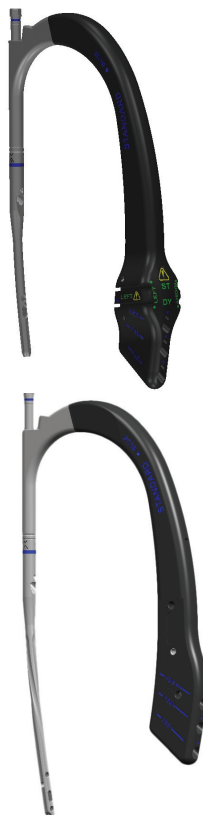

Fig. 12

Fig. 13

**! Both a MODULAR STANDARD (00-2490-003-10) and STANDARD (00-2490-003-00) TARGETING GUIDE exists. When implanting a short nail the STANDARD TARGETING GUIDE (Fig. 12) must be used. When implanting a long nail, either the MODULAR STANDARD TARGETING GUIDE (Fig. 13) or STANDARD TARGETING GUIDE can be used.**

Place the CONNECTING BOLT through the barrel of the TARGETING GUIDE (Fig. 14). The arrow on the nail (with an R for a Right Nail or an L for a Left Nail) will line up with the arrow on the barrel of the guide when the nail is correctly aligned.

Begin threading the CONNECTING BOLT (by hand or using the CONNECTING BOLT INSERTER) into the proximal portion of the nail. Orient the proximal portion of the nail so that the slots in the nail match up with the corresponding tines on the barrel of the TARGETING GUIDE. Completely tighten the CONNECTING BOLT using an 11mm WRENCH to secure the nail to the guide (Fig 15).



Fig. 14

Fig. 15

Lay the guide attached to the nail over the femur. Confirm that the bow of the nail is anterior similar to the bow of the femur. Confirm also that the lag screw hole in the nail is oriented to guide a lag screw into the femoral head. Care must be taken to ensure that the correct nail is selected and that it is assembled correctly to the guide. If this is not the case, loosen and reattach the nail appropriately or choose the correct nail and attach it to the guide.

**!** Use a LAG SCREW CANNULA and the LAG SCREW REAMER or a CANNULA, DRILL SLEEVE AND DRILL to verify that the guide will target all required holes in the nail correctly. Hole indicators can be placed in static (ST) and dynamic (DY) holes of the targeting guide and in holes for CCD angles that will not be used to avoid the accidental use of those holes during the surgery. Use a push-and-twist motion when inserting the hole indicators to help ensure that they stay in place.

**!** The STANDARD TARGETING GUIDE is designed to target the transverse distal static (ST) and dynamic (DY) holes in SHORT nails. As the guide is designed to work with both left and right ST and DY holes, care must be taken to ensure that the correct ST/DY holes will be used for the surgery (use the left holes when using a left nail, and vice versa). The holes that will be used to place screws into the distal portion of SHORT NAILS are on the anterior side of the guide when the patient is in a supine position.

**!** The MODULAR STANDARD TARGETING GUIDE (00-2490-003-10) is not designed to target the transverse distal static (ST) and dynamic (DY) holes and therefore should not be used with short nails.



Fig. 16



Fig. 17

Insert the nail over the GUIDE WIRE with the arm of the guide facing anteriorly (Fig. 16).

As the nail passes through the canal, it will naturally turn approximately 90° until the anterior bow of the nail is in line with the bow of the femur. Monitor the progression of the nail down the canal using the C-arm, especially as the nail is passing through or near the fracture site.

**CAUTION: Do not pry excessively on the targeting guide as damage may result.**

If the nail does not pass down the canal easily, attach the IMPACTION HEAD to the TARGETING GUIDE. Using the MALLET, impact gently on the IMPACTION HEAD (Fig. 17).

**CAUTION: Do not strike excessively as damage to the guide and bone may result. Verify that the CONNECTING BOLT is tight while, and after, impacting. Do not impact on any portion of the TARGETING GUIDE as this may break the guide or cause it to lose its accuracy.**

If the nail will not advance with impaction, remove the nail and ream the canal to a larger diameter at additional 0.5 mm increments or consider using a smaller diameter nail.

Anteversion can be verified by placing a threaded guide pin through the skin and soft tissue along the anterior axis of the femoral neck.

Remove the GUIDE WIRE from the nail using the GUIDE WIRE GRIPPER.

If it is desired to utilize an antirotation pin to assist in stabilizing the femoral head during lag screw preparation and insertion, a 3.2mm PIN can be used. It can be placed using a freehand technique anterior to the nail and into the femoral neck and head.<sup>1,2</sup>



**⚠ The holes proximal to the lag screw cannula holes in the STANDARD TARGETING GUIDE are used merely as a general reference for the pin placement through the implant antirotation pin hole and must not be solely relied upon to accurately place the pin.**

### Lag Screw Placement

For the STANDARD and MODULAR STANDARD GUIDES, instruments marked BLUE are utilized to place the LAG SCREW. Marks on the targeting guides near the holes indicate the color of cannula that should be passed through that specific hole. The chart below details the color coded instruments that are used to target and place the lag screw.

Instrument Type	Standard
Lag Screw Cannula	Blue
Lag Screw Pin Sleeve	Blue
Lag Screw Reamer	Blue
Lag Screw Tap	Blue
Lag Screw Inserter	Blue
Lag Screw Retaining Shaft	Blue

**CAUTION: Retighten the CONNECTING BOLT to the nail to maintain targeting accuracy.**

The Tip-Apex Distance (TAD), the sum of the distances of the tip of the lag screw to the apex of the femoral head in the A/P and Lateral x-ray views, has been shown to be a key indicator in reducing cut-out of lag screws in the femoral head. The TAD should be less than 25mm.<sup>3</sup>

Position the TARGETING GUIDE so that the trajectory of the LAG SCREW CANNULA will place the lag screw in the appropriate position in the femoral head and neck. PINS can be held over the skin in line with the LAG SCREW CANNULA to help estimate this position and correct CCD angle.

**NOTE: If planning to use an ANTIROTATION PIN to further stabilize the femoral head, insert the DOUBLE CANNULA instead of the LAG SCREW CANNULA.**

Assemble the LAG SCREW TROCAR into the LAG SCREW CANNULA and pass through the correct hole in the TARGETING GUIDE for the chosen CCD angle. The lag screw hole labeled 125 is designed to be used with the long and short nails containing a 125° CCD angle, the lag screw hole labeled 130 is designed to be used with the long and short nails containing a 130° CCD angle, and the lag screw hole labeled 135 is designed to be used with the long and short nails containing a 135° CCD angle. Make a small skin incision, then dissect through the fascia and other soft tissues down to the bone. Advance the cannula through the guide down to the bone (Fig. 18).

**CAUTION: Do not impact on the cannula, as the tip of the cannula may skive along the bone and prevent accurate targeting**



Fig. 18

**CAUTION: Both 3.0mm and 3.2mm instruments (guide pins, depth gauges, reamers, taps, pin sleeves) are available. The 3.2mm versions of the instruments can easily be distinguished as they have gold coating on them. The 3.0mm and 3.2mm instruments can not be used interchangeably. Mixing of these instruments can lead to lag screw mis-measurement which could result in patient injury and/or damage to the instruments.**

This technique describes use of the 3.2mm instruments. The 3.0mm instruments can be used in an identical fashion.



Fig. 19

Another A/P C-arm image can be taken at this point to ensure that the TARGETING GUIDE is still aligned correctly by visualizing a line extending from the center of the cannula into the femoral head. Remove the TROCAR and insert the 3.2mm LAG SCREW PIN SLEEVE. Insert a 3.2mm PIN through the PIN SLEEVE. Under fluoroscopy, drill the PIN to the level of the subchondral bone of the femoral head without penetrating the femoral cortex (Fig. 19).

Assess the position of the PIN using the C-arm in the A/P and Lateral planes. If the PIN is appropriately placed, proceed with the next steps.

**NOTE: If the PIN is not appropriately placed, remove it, adjust the guide under fluoroscopy and replace the PIN correctly.**

**TECHNIQUE TIP – If the PIN appears to be changing direction at the point it enters the lateral cortex of the femur, remove the pin and pin sleeve and perforate the lateral cortex using the lag screw reamer. Replace the pin sleeve in the cannula and drive the pin as previously stated to the level of the subchondral bone in the femoral head.**

<sup>3</sup> Baumgaertner et.al., The value of the tip-apex distance in predicting failure of fixation of peritrochanteric fractures of the hip, J Bone Joint Surg AM. 1995;77:1058-1064

If it is desired to utilize an ANTIROTATION PIN to assist in stabilizing the femoral head during lag screw insertion, a 3.0mm ANTIROTATION PIN can be placed into the femoral neck and head using a DOUBLE CANNULA. Use the smaller sleeve of the DOUBLE CANNULA to place this pin at this time. The pin is passed so that it does not penetrate the femoral cortex in the femoral head or neck (Fig. 20). Place pin to appropriate depth beyond fracture site to provide stabilization.

**NOTE: Place the 3.2mm PIN prior to the ANTIROTATION PIN to reduce mis-targeting. Position the ANTIROTATION PIN slightly proximal to the center-line of the femoral neck.**



Fig. 20

Alternatively, the pin can be placed using a freehand technique anterior to the nail and into the femoral neck and head.<sup>4,5</sup>

**NOTE: Insert 3.2mm pin anterior to the nail. Inserting them posterior to the nail may cause damage to the neurovascular structures.**

Remove the 3.2mm LAG SCREW PIN SLEEVE from The LAG SCREW CANNULA.

Slide the CANNULATED LAG SCREW DEPTH GAUGE over the 3.2mm PIN down to the bone (Fig. 21).

Confirm that the depth gauge is touching the lateral cortex of the femur using fluoroscopy to accurately determine the length of lag screw to be used. The end of

the PIN in the depth gauge indicates the length of lag screw to be used.

Slide the LAG SCREW STOP ASSEMBLY onto the LAG SCREW REAMER (Fig. 22). Place the window in the stop over the number measured with the CANNULATED LAG SCREW DEPTH GAUGE (Fig. 23). If the measurement was between markings on the cannulated depth gauge, set the stop to the smaller number.

Prior to reaming, manually bend the ANTIROTATION PIN approximately 30° away from the path of the 3.2mm PIN. Attach the LAG SCREW REAMER to the drill. Ream over the PIN to the level of the subchondral bone (Fig. 24). While drilling, use the C-arm intermittently to verify position of the reamer and to make sure that the PIN is not migrating through the femoral head. Remove the reamer. Push the end of the PIN while withdrawing the power tool.



Fig. 21



Fig. 22

The lag screw is self tapping. If preferred, tap a hole for the lag screw over the PIN. The stop can be used to indicate the appropriate depth gauge.

Select the appropriate length LAG SCREW based on previous measurements. The SCREW DEPTH GAUGE can also be used to verify the length of lag screw that should be used.

Attach the LAG SCREW to the LAG SCREW INSERTER using the LAG SCREW RETAINING SHAFT to fully secure the screw to the inserter (Fig. 25).



Fig. 23



Fig. 24



Fig. 25

<sup>4</sup> AO Principles of Fracture Management, Thieme, 2000

<sup>5</sup> Browner et.al., Skeletal Trauma Vol. 2, Basic Science, Management and Reconstruction, p.1929 – 1931, 2003

If compression is planned, thread the COMPRESSION DEVICE onto the LAG SCREW INSERTER and twist it to the level of the handle (Fig. 26). This may be done before or after attaching the lag screw.

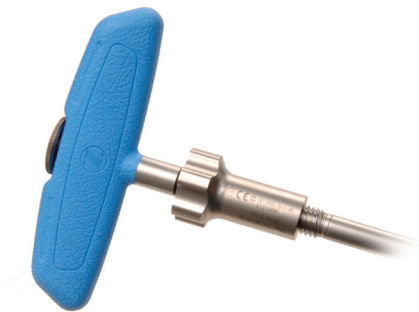

Fig. 26

Insert the LAG SCREW over the PIN and into the femur (Fig. 27). Confirm placement using the C-arm. The handle on the LAG SCREW INSERTER must be parallel or perpendicular to the axis of the guide (indicated by colored dots between the holes for the lag screw cannulas). Rotate the LAG SCREW INSERTER up to 90° in order to correctly orient the handle to the guide (Fig. 28).

**NOTE: Do not overtighten the lag screw. The distal edge must protrude laterally through the femur to ensure that sliding can occur.**

**TECHNIQUE TIP: If using an ANTIROTATION PIN through the nail, position the T-handle perpendicular to the guide. This reduces the risk of interference when removing the ANTIROTATION PIN.**



Fig. 27



Fig. 28

**NOTE: Remove the ANTIROTATION PIN (if used).**

If compression is desired, twist the COMPRESSION DEVICE in a clockwise fashion (Fig. 29).



Fig. 29

As the device presses against the LAG SCREW CANNULA, it will generate compression across the fracture (Fig. 30). Compress as needed to reduce the fracture.



Fig. 30

A SET SCREW (included in the lag screw package or packaged separately) must be used to prevent the lag screw from rotating post-operatively. Insert the tip of the FLEXIBLE CAPTURED SET SCREW DRIVER or 3.5mm HEX SCREWDRIVER into the 3.5mm hex end of the SET SCREW (Fig. 31).

The SET SCREW is then passed through the CONNECTING BOLT into the proximal portion of the nail (Fig. 32).



Fig. 31



Fig. 32

**NOTE:** If using the FLEXIBLE CAPTURED SET SCREW DRIVER make sure that it is not used at an angle greater than 40°. If it is used at an angle greater than 40°, it may be damaged.

**NOTE:** Do not drive the set screw into the nail under power as damage to the set screw or the nail could result.

The SET SCREW should be tightened down into the groove in the lag screw. As noted above, the LAG SCREW INSERTER must be positioned so that the handle on the inserter is parallel or perpendicular to the colored dots on the TARGETING GUIDE in order for the SET SCREW and LAG SCREW grooves to engage properly. To verify engagement, attempt to twist the LAG SCREW INSERTER. If it cannot be rotated using a reasonable amount of force, the construct is in the correct position. If rotation is possible, adjust the position of the LAG SCREW (rotate slightly) so that the set screw can enter the groove in the LAG SCREW (Fig. 33).



Fig. 33

**NOTE:** To achieve sliding, tighten the SET SCREW and then rotate the FLEXIBLE CAPTURED SET SCREW DRIVER counterclockwise one quarter turn. Do not unscrew the SET SCREW more than one quarter turn. Make sure that the SET SCREW is still engaged in the groove by checking that it is still not possible to turn the LAG SCREW with the LAG SCREW INSERTER.

Disengage the LAG SCREW INSERTER from the LAG SCREW. A 3.5mm HEX SCREWDRIIVER may be used to disengage the LAG SCREW RETAINING SHAFT from the LAG SCREW.

**TECHNIQUE TIP:** The LAG SCREW CANNULA can be left in place to aid in stabilizing the construct during distal screw placement in the short nails, if desired (Fig. 34). Remove the FLEXIBLE CAPTURED SET SCREW DRIVER and set aside.

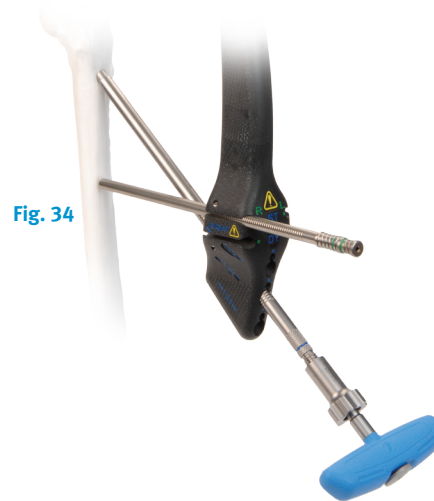

Fig. 34

### Distal Targeting For Short Nails

Color coded instruments are also used for distal targeting of short nails. For the STANDARD TARGETING GUIDE, instruments marked GREEN are utilized to place the distal screws. The chart below details the color coded instruments that are used for distal targeting and distal screw placement.

Instrument Type	Standard
8.0mm Screw Cannula	Green
4.3mm Drill Sleeve	Green-Red
4.3mm Drill Bit	Green-Red
Screwdriver	Green
Screw Depth Gauge	Green

**!** The STANDARD TARGETING GUIDE is designed to target the distal static (ST) and dynamic (DY) holes in SHORT nails. As the guide is designed to work with both left and right ST and

DY holes, care must be taken to ensure that the correct targeting holes (left or right) are used for drilling and screw placement. At this point in the surgery, with the guide oriented horizontally and the nail in place, the correct holes are on the top (anterior) side of the guide. A YELLOW CAUTION SYMBOL is engraved on the face of the guide near the ST/DY holes to remind the surgeon to take note of the placement of the screw. Additionally, the words "LEFT" and "RIGHT" are embossed in green on the appropriate side of the guide where the SCREW CANNULAS should be placed to insert these screws.

**!** The MODULAR STANDARD TARGETING GUIDE can not be used to distal target the short nails.

Assemble the TROCAR to the 8.0mm CANNULA. Pass the CANNULA through the appropriate hole in the TARGETING GUIDE to target the distal hole or slot. The hole is labeled ST is for the Static Hole. The hole labeled DY is for the Dynamic Slot.

After pressing the tip of the TROCAR and CANNULA against the skin, make a small incision at that point through the skin and fascia lata. Spread the soft tissue down to the bone. Advance the CANNULA down to the bone.

**CAUTION:** Do not impact on the CANNULA or TROCAR, as the tip of the cannula may skive along the bone and prevent accurate targeting.

Remove the TROCAR (if used) and insert the 4,3mm DRILL SLEEVE into the CANNULA.

Utilize the 4.3mm DRILL BIT to drill through both cortices of bone. The depth of the hole can be measured using calibrations on the DRILL BIT. Another option is to remove the drill bit and the drill sleeve and then use the SCREW DEPTH GAUGE to measure the depth of the hole.

**CAUTION:** In cases where hard cortical bone is encountered, or at the surgeon's preference, a 5.0mm TAP (00-2490-048-50) can be used to ease insertion of the screws.



The nail utilizes a 5.0mm screw distally. The screw packages are labeled with the color RED. The distal hole and slot in the nail allows for standard or fixed angle locking. To achieve STANDARD LOCKING, choose a PARTIALLY THREADED 5.0mm SCREW. To achieve a FIXED ANGLE construct, choose a FIXED ANGLE 5.0mm SCREW (Fig 35), applicable for long nails only). In SHORT nails, either screw type will result in a STANDARD LOCKING construct.

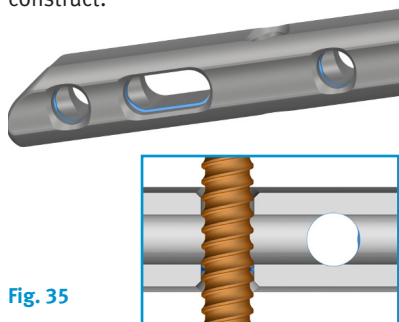

Fig. 35

Choose the appropriate length screw based on the DEPTH GAUGE or DRILL BIT reading. Use the 3.5mm HEX SCREWDRIVER to place the screw bicortically through the bone.

If using the CAPTURED SCREWDRIVER, place the appropriate screw on the 3.5mm HEX and tighten the screw to the CAPTURED SCREWDRIVER by turning the knob next to the handle clockwise.

**CAUTION: If using the CAPTURED SCREW DRIVER, do not torque the CAPTURED SCREWDRIVER beyond the calibration line next to the handle.**

**CAUTION: Do not drive the screws into the bone under power, as damage to the bone, screws and nail could result.**

Remove the screwdriver and cannula. If desired, repeat these steps to place another screw in the other hole or slot. If not previously done, remove the LAG SCREW CANNULA.

### Freehand Technique for Long Nails

Insert the FREE HAND 4.3mm DRILL BIT (RED) into the DISTAL TARGETING DEVICE. Finger tighten the SET SCREW. Position

the C-arm in order to get a lateral view of the distal femur. Adjust the angle of the C-arm so that the hole through the nail appears as a perfect circle on the monitor. Bring the tip of the drill bit to the skin and use the C-arm to center it over the hole that you desire to place a screw through. Make a stab wound at this point and dissect down to the bone. Place the tip of the drill bit against the bone. Verify that the tip of the drill bit is in the center of the hole. Align the drill bit with the C-arm beam. Tap the drill bit into the bone using the MALLET.

Remove the DISTAL TARGETING DEVICE. Slide the FREE HAND TISSUE PROTECTION SLEEVE over the DRILL BIT. Attach the DRILL to the FREE HAND 4.3mm DRILL BIT and advance the drill bit through the bone. Verify that the drill bit has gone through the hole in the nail.

Remove the drill bit. Measure the depth of the hole using the FREE HAND SCREW DEPTH GAUGE. Insert the appropriate length screw using the screwdriver.

If using the CAPTURED SCREWDRIVER, place the appropriate screw on the 3.5mm HEX and tighten the screw to the CAPTURED SCREWDRIVER by turning the knob next to the handle clockwise (Fig. 36).

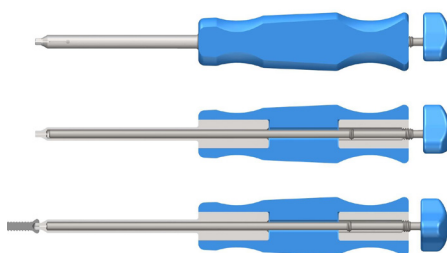

Fig. 36

**CAUTION: If using the CAPTURED SCREW DRIVER, do not torque the CAPTURED SCREWDRIVER beyond the calibration line next to the handle.**

**CAUTION: Do not drive the screws into the bone under power, as damage to the bone, screws and nail could result.**

Repeat these steps to insert additional distal screws.

### Final Implant Placement

Observe the depth of the nail in the proximal femur. Ridges at 5 and 10mm from the end of the targeting guide barrel indicate nail depth.

It is recommended to use a NAIL CAP to close the proximal part of the nail to prevent bone ingrowth.

Place a 2.0mm GUIDE PIN through the CONNECTING BOLT and into the proximal portion of the NAIL. Loosen and remove the CONNECTING BOLT from the nail taking care to leave the 2.0mm GUIDE PIN in place. If a NAIL CAP will not be used, do not introduce the 2.0mm GUIDE PIN.

**TECHNIQUE NOTE: The 0mm height NAIL CAP can be placed through the TARGETING GUIDE following removal of the CONNECTING BOLT. Other NAIL CAPS cannot be placed until the TARGETING GUIDE is also removed.**

Choose the appropriate height of NAIL CAP. Secure the selected NAIL CAP to the NAIL CAP INSERTER using the NAIL CAP RETAINING SHAFT (Fig. 37).



Fig. 37

Place the NAIL CAP over the 2.0mm GUIDE WIRE and thread it into the top of the NAIL. Using the C-arm, verify that the cap is completely seated in the top of the nail.

Disengage the NAIL CAP INSERTER from the NAIL CAP. Remove the 2.0mm GUIDE PIN.

Close all wounds and apply the appropriate dressings.

\* It is the responsibility of the surgeon to determine what is the most suitable postoperative care depending on each patient's health condition.



### Postoperative Care

Early range of motion exercises of the knee and ankle are encouraged. Allow toe-touch weight bearing to progress to full weight bearing as fracture callus increases on the x-ray films.\*

### Nail Extraction

Use the C-arm to locate any distal screws. Remove the screws using a 3.5mm HEX SCREWDRIVER. Remove the NAIL CAP (if one was inserted) with a 5.0mm HEX SCREWDRIVER. Use a 3.5mm HEX SCREWDRIVER to remove the set screw. Expose the lag screw and use the LAG SCREW INSERTER to remove it.

**NOTE: To remove the lag screw it is not necessary that the set screw is completely removed. Turn the set screw two turns backwards and make sure that the set screw is still engaged in the threads of the nail.**

**NOTE: It is recommended to use the LAG SCREW CANNULA as guidance for the LAG SCREW INSERTER while removing the lag screw. Assemble the LAG SCREW INSERTER through the LAG SCREW CANNULA into the lag screw. Use the compression device to push the LAG SCREW CANNULA to the bone. Make sure the LAG SCREW INSERTER is fully seated. Hand tighten the LAG SCREW INSERTER with the 3.5mm HEX SCREWDRIVER.**

To remove the nail, slide a 3.0mm x 100cm GUIDE WIRE through the nail. Insert the CEPHALOMEDULLARY CANNULATED EXTRACTION ADAPTER over the wire into the top of the nail. Tighten the adapter to the nail. Attach a SLAPHAMMER or other impaction device and impact to back out the nail. The nail should move with each impaction. Periodically retighten the adapter and/or SLAPHAMMER during extraction as needed. The nail may rotate as it passes through the canal during extraction.

### Cephalomedullary Long Nail Details

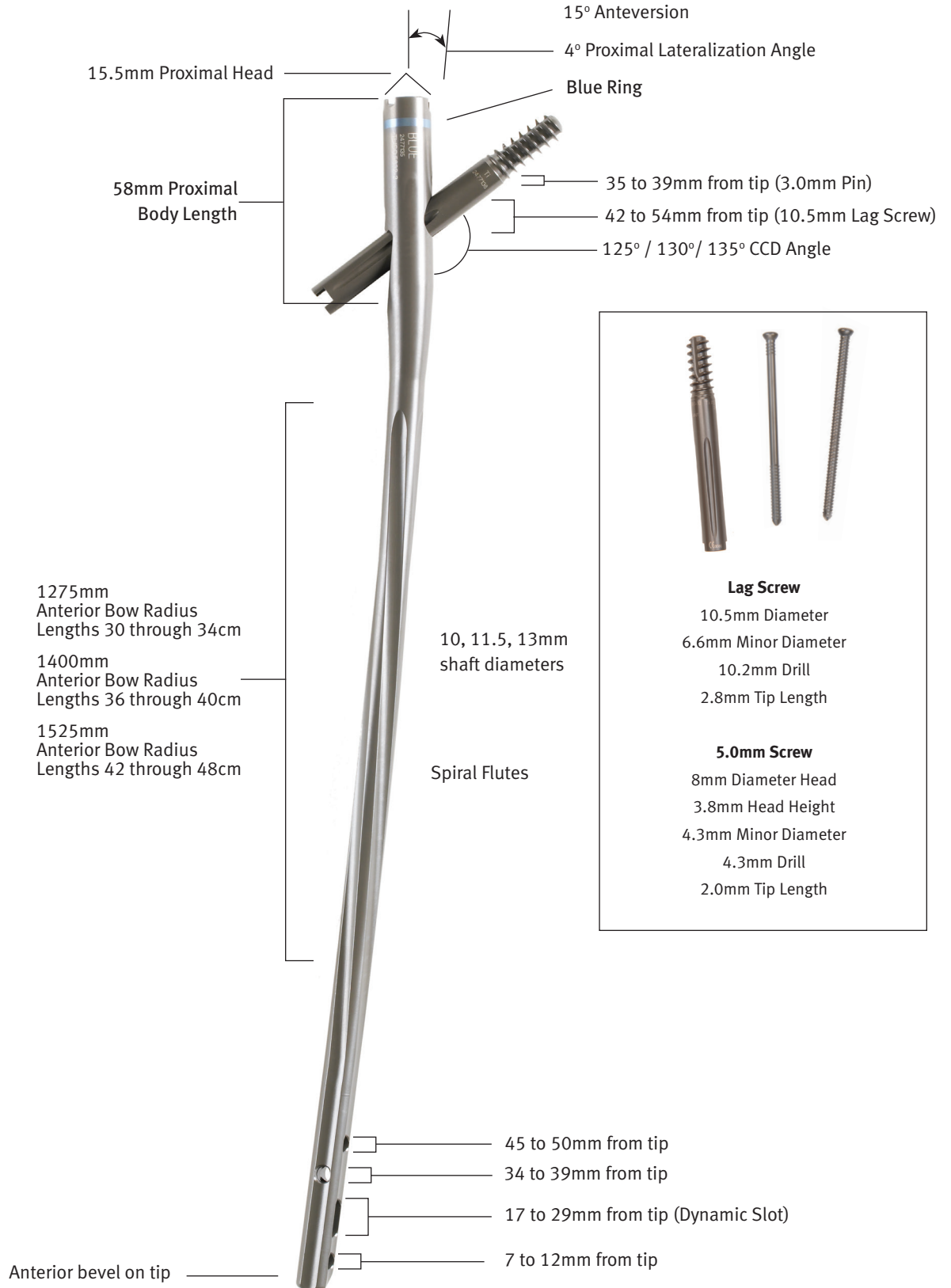

## Cephalomedullary Short Nail Details

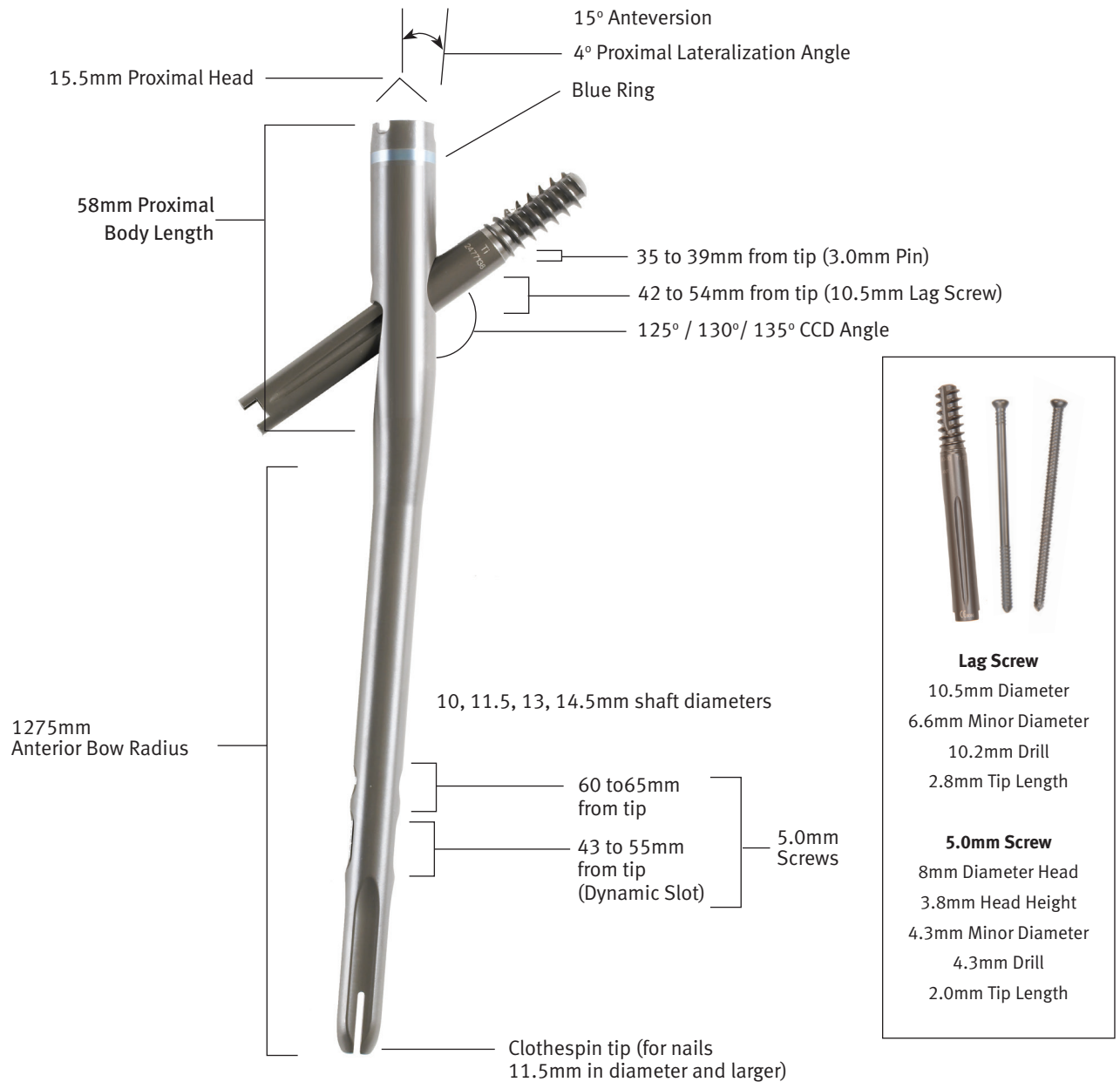

**NOTE: There is no locking tab (Stabilize Technology) for the Cephalomedullary Short Nails.**

## Product Information

### Cephalomedullary Short Nails

Item Number	Product Description
47-2493-210-10	Cephalomedullary Short Nail 10mm X 21.5cm 125 CCD Right Ti-6Al-4V Alloy
47-2493-211-10	Cephalomedullary Short Nail 10mm X 21.5cm 125 CCD Left Ti-6Al-4V Alloy
47-2493-212-10	Cephalomedullary Short Nail 10mm X 21.5cm 130 CCD Right Ti-6Al-4V Alloy
47-2493-213-10	Cephalomedullary Short Nail 10mm X 21.5cm 130 CCD Left Ti-6Al-4V Alloy
47-2493-214-10	Cephalomedullary Short Nail 10mm X 21.5cm 135 CCD Right Ti-6Al-4V Alloy
47-2493-215-10	Cephalomedullary Short Nail 10mm X 21.5cm 135 CCD Left Ti-6Al-4V Alloy
47-2493-210-11	Cephalomedullary Short Nail 11.5mm X 21.5cm 125 CCD Right Ti-6Al-4V Alloy
47-2493-211-11	Cephalomedullary Short Nail 11.5mm X 21.5cm 125 CCD Left Ti-6Al-4V Alloy
47-2493-212-11	Cephalomedullary Short Nail 11.5mm X 21.5cm 130 CCD Right Ti-6Al-4V Alloy
47-2493-213-11	Cephalomedullary Short Nail 11.5mm X 21.5cm 130 CCD Left Ti-6Al-4V Alloy
47-2493-214-11	Cephalomedullary Short Nail 11.5mm X 21.5cm 135 CCD Right Ti-6Al-4V Alloy
47-2493-215-11	Cephalomedullary Short Nail 11.5mm X 21.5cm 135 CCD Left Ti-6Al-4V Alloy
47-2493-210-13	Cephalomedullary Short Nail 13mm X 21.5cm 125 CCD Right Ti-6Al-4V Alloy
47-2493-211-13	Cephalomedullary Short Nail 13mm X 21.5cm 125 CCD Left Ti-6Al-4V Alloy
47-2493-212-13	Cephalomedullary Short Nail 13mm X 21.5cm 130 CCD Right Ti-6Al-4V Alloy
47-2493-213-13	Cephalomedullary Short Nail 13mm X 21.5cm 130 CCD Left Ti-6Al-4V Alloy
47-2493-214-13	Cephalomedullary Short Nail 13mm X 21.5cm 135 CCD Right Ti-6Al-4V Alloy
47-2493-215-13	Cephalomedullary Short Nail 13mm X 21.5cm 135 CCD Left Ti-6Al-4V Alloy
47-2493-210-14	Cephalomedullary Short Nail 14.5mm X 21.5cm 125 CCD Right Ti-6Al-4V Alloy
47-2493-211-14	Cephalomedullary Short Nail 14.5mm X 21.5cm 125 CCD Left Ti-6Al-4V Alloy
47-2493-212-14	Cephalomedullary Short Nail 14.5mm X 21.5cm 130 CCD Right Ti-6Al-4V Alloy
47-2493-213-14	Cephalomedullary Short Nail 14.5mm X 21.5cm 130 CCD Left Ti-6Al-4V Alloy
47-2493-214-14	Cephalomedullary Short Nail 14.5mm X 21.5cm 135 CCD Right Ti-6Al-4V Alloy
47-2493-215-14	Cephalomedullary Short Nail 14.5mm X 21.5cm 135 CCD Left Ti-6Al-4V Alloy

### Cephalomedullary Long Nails

Item Number	Product Description
47-2493-300-10	Cephalomedullary Long Nail 10mm X 30cm 125 CCD Right Ti-6Al-4V Alloy
47-2493-301-10	Cephalomedullary Long Nail 10mm X 30cm 125 CCD Left Ti-6Al-4V Alloy
47-2493-302-10	Cephalomedullary Long Nail 10mm X 30cm 130 CCD Right Ti-6Al-4V Alloy
47-2493-303-10	Cephalomedullary Long Nail 10mm X 30cm 130 CCD Left Ti-6Al-4V Alloy
47-2493-304-10	Cephalomedullary Long Nail 10mm X 30cm 135 CCD Right Ti-6Al-4V Alloy
47-2493-305-10	Cephalomedullary Long Nail 10mm X 30cm 135 CCD Left Ti-6Al-4V Alloy
47-2493-320-10	Cephalomedullary Long Nail 10mm X 32cm 125 CCD Right Ti-6Al-4V Alloy
47-2493-321-10	Cephalomedullary Long Nail 10mm X 32cm 125 CCD Left Ti-6Al-4V Alloy
47-2493-322-10	Cephalomedullary Long Nail 10mm X 32cm 130 CCD Right Ti-6Al-4V Alloy
47-2493-323-10	Cephalomedullary Long Nail 10mm X 32cm 130 CCD Left Ti-6Al-4V Alloy
47-2493-324-10	Cephalomedullary Long Nail 10mm X 32cm 135 CCD Right Ti-6Al-4V Alloy
47-2493-325-10	Cephalomedullary Long Nail 10mm X 32cm 135 CCD Left Ti-6Al-4V Alloy
47-2493-340-10	Cephalomedullary Long Nail 10mm X 34cm 125 CCD Right Ti-6Al-4V Alloy
47-2493-341-10	Cephalomedullary Long Nail 10mm X 34cm 125 CCD Left Ti-6Al-4V Alloy
47-2493-342-10	Cephalomedullary Long Nail 10mm X 34cm 130 CCD Right Ti-6Al-4V Alloy
47-2493-343-10	Cephalomedullary Long Nail 10mm X 34cm 130 CCD Left Ti-6Al-4V Alloy
47-2493-344-10	Cephalomedullary Long Nail 10mm X 34cm 135 CCD Right Ti-6Al-4V Alloy
47-2493-345-10	Cephalomedullary Long Nail 10mm X 34cm 135 CCD Left Ti-6Al-4V Alloy
47-2493-360-10	Cephalomedullary Long Nail 10mm X 36cm 125 CCD Right Ti-6Al-4V Alloy
47-2493-361-10	Cephalomedullary Long Nail 10mm X 36cm 125 CCD Left Ti-6Al-4V Alloy
47-2493-362-10	Cephalomedullary Long Nail 10mm X 36cm 130 CCD Right Ti-6Al-4V Alloy
47-2493-363-10	Cephalomedullary Long Nail 10mm X 36cm 130 CCD Left Ti-6Al-4V Alloy
47-2493-364-10	Cephalomedullary Long Nail 10mm X 36cm 135 CCD Right Ti-6Al-4V Alloy
47-2493-365-10	Cephalomedullary Long Nail 10mm X 36cm 135 CCD Left Ti-6Al-4V Alloy
47-2493-380-10	Cephalomedullary Long Nail 10mm X 38cm 125 CCD Right Ti-6Al-4V Alloy
47-2493-381-10	Cephalomedullary Long Nail 10mm X 38cm 125 CCD Left Ti-6Al-4V Alloy
47-2493-382-10	Cephalomedullary Long Nail 10mm X 38cm 130 CCD Right Ti-6Al-4V Alloy
47-2493-383-10	Cephalomedullary Long Nail 10mm X 38cm 130 CCD Left Ti-6Al-4V Alloy
47-2493-384-10	Cephalomedullary Long Nail 10mm X 38cm 135 CCD Right Ti-6Al-4V Alloy







47-2493-385-13	Cephalomedullary Long Nail 13mm X 38cm 135 CCD Left Ti-6Al-4V Alloy
47-2493-400-13	Cephalomedullary Long Nail 13mm X 40cm 125 CCD Right Ti-6Al-4V Alloy
47-2493-401-13	Cephalomedullary Long Nail 13mm X 40cm 125 CCD Left Ti-6Al-4V Alloy
47-2493-402-13	Cephalomedullary Long Nail 13mm X 40cm 130 CCD Right Ti-6Al-4V Alloy
47-2493-403-13	Cephalomedullary Long Nail 13mm X 40cm 130 CCD Left Ti-6Al-4V Alloy
47-2493-404-13	Cephalomedullary Long Nail 13mm X 40cm 135 CCD Right Ti-6Al-4V Alloy
47-2493-405-13	Cephalomedullary Long Nail 13mm X 40cm 135 CCD Left Ti-6Al-4V Alloy
47-2493-420-13	Cephalomedullary Long Nail 13mm X 42cm 125 CCD Right Ti-6Al-4V Alloy
47-2493-421-13	Cephalomedullary Long Nail 13mm X 42cm 125 CCD Left Ti-6Al-4V Alloy
47-2493-422-13	Cephalomedullary Long Nail 13mm X 42cm 130 CCD Right Ti-6Al-4V Alloy
47-2493-423-13	Cephalomedullary Long Nail 13mm X 42cm 130 CCD Left Ti-6Al-4V Alloy
47-2493-424-13	Cephalomedullary Long Nail 13mm X 42cm 135 CCD Right Ti-6Al-4V Alloy
47-2493-425-13	Cephalomedullary Long Nail 13mm X 42cm 135 CCD Left Ti-6Al-4V Alloy
47-2493-440-13	Cephalomedullary Long Nail 13mm X 44cm 125 CCD Right Ti-6Al-4V Alloy
47-2493-441-13	Cephalomedullary Long Nail 13mm X 44cm 125 CCD Left Ti-6Al-4V Alloy
47-2493-442-13	Cephalomedullary Long Nail 13mm X 44cm 130 CCD Right Ti-6Al-4V Alloy
47-2493-443-13	Cephalomedullary Long Nail 13mm X 44cm 130 CCD Left Ti-6Al-4V Alloy
47-2493-444-13	Cephalomedullary Long Nail 13mm X 44cm 135 CCD Right Ti-6Al-4V Alloy
47-2493-445-13	Cephalomedullary Long Nail 13mm X 44cm 135 CCD Left Ti-6Al-4V Alloy
47-2493-460-13	Cephalomedullary Long Nail 13mm X 46cm 125 CCD Right Ti-6Al-4V Alloy
47-2493-461-13	Cephalomedullary Long Nail 13mm X 46cm 125 CCD Left Ti-6Al-4V Alloy
47-2493-462-13	Cephalomedullary Long Nail 13mm X 46cm 130 CCD Right Ti-6Al-4V Alloy
47-2493-463-13	Cephalomedullary Long Nail 13mm X 46cm 130 CCD Left Ti-6Al-4V Alloy
47-2493-464-13	Cephalomedullary Long Nail 13mm X 46cm 135 CCD Right Ti-6Al-4V Alloy
47-2493-465-13	Cephalomedullary Long Nail 13mm X 46cm 135 CCD Left Ti-6Al-4V Alloy
47-2493-480-13	Cephalomedullary Long Nail 13mm X 48cm 125 CCD Right Ti-6Al-4V Alloy
47-2493-481-13	Cephalomedullary Long Nail 13mm X 48cm 125 CCD Left Ti-6Al-4V Alloy
47-2493-482-13	Cephalomedullary Long Nail 13mm X 48cm 130 CCD Right Ti-6Al-4V Alloy
47-2493-483-13	Cephalomedullary Long Nail 13mm X 48cm 130 CCD Left Ti-6Al-4V Alloy
47-2493-484-13	Cephalomedullary Long Nail 13mm X 48cm 135 CCD Right Ti-6Al-4V Alloy
47-2493-485-13	Cephalomedullary Long Nail 13mm X 48cm 135 CCD Left Ti-6Al-4V Alloy

## 10.5mm Lag Screws

Item Number	Product Description
47-2485-070-10	10.5mm Lag Screw 70mm Length Ti-6Al-4V Alloy
47-2485-075-10	10.5mm Lag Screw 75mm Length Ti-6Al-4V Alloy
47-2485-080-10	10.5mm Lag Screw 80mm Length Ti-6Al-4V Alloy
47-2485-085-10	10.5mm Lag Screw 85mm Length Ti-6Al-4V Alloy
47-2485-090-10	10.5mm Lag Screw 90mm Length Ti-6Al-4V Alloy
47-2485-095-10	10.5mm Lag Screw 95mm Length Ti-6Al-4V Alloy
47-2485-100-10	10.5mm Lag Screw 100mm Length Ti-6Al-4V Alloy
47-2485-105-10	10.5mm Lag Screw 105mm Length Ti-6Al-4V Alloy
47-2485-110-10	10.5mm Lag Screw 110mm Length Ti-6Al-4V Alloy
47-2485-115-10	10.5mm Lag Screw 115mm Length Ti-6Al-4V Alloy
47-2485-120-10	10.5mm Lag Screw 120mm Length Ti-6Al-4V Alloy
47-2485-125-10	10.5mm Lag Screw 125mm Length Ti-6Al-4V Alloy
47-2485-130-10	10.5mm Lag Screw 130mm Length Ti-6Al-4V Alloy

## 5.0mm Screws (for distal screw holes)

Item Number	Product Description
47-2483-020-50	5.0mm Cortical Screw 20mm Length Ti-6Al-4V Alloy Partially Threaded 3.5mm Hex Head
47-2483-022-50	5.0mm Cortical Screw 22.5mm Length Ti-6Al-4V Alloy Partially Threaded 3.5mm Hex Head
47-2483-025-50	5.0mm Cortical Screw 25mm Length Ti-6Al-4V Alloy Partially Threaded 3.5mm Hex Head
47-2483-027-50	5.0mm Cortical Screw 27.5mm Length Ti-6Al-4V Alloy Partially Threaded 3.5mm Hex Head
47-2483-030-50	5.0mm Cortical Screw 30mm Length Ti-6Al-4V Alloy Partially Threaded 3.5mm Hex Head
47-2483-032-50	5.0mm Cortical Screw 32.5mm Length Ti-6Al-4V Alloy Partially Threaded 3.5mm Hex Head
47-2483-035-50	5.0mm Cortical Screw 35mm Length Ti-6Al-4V Alloy Partially Threaded 3.5mm Hex Head
47-2483-037-50	5.0mm Cortical Screw 37.5mm Length Ti-6Al-4V Alloy Partially Threaded 3.5mm Hex Head
47-2483-040-50	5.0mm Cortical Screw 40mm Length Ti-6Al-4V Alloy Partially Threaded 3.5mm Hex Head
47-2483-042-50	5.0mm Cortical Screw 42.5mm Length Ti-6Al-4V Alloy Partially Threaded 3.5mm Hex Head
47-2483-045-50	5.0mm Cortical Screw 45mm Length Ti-6Al-4V Alloy Partially Threaded 3.5mm Hex Head
47-2483-047-50	5.0mm Cortical Screw 47.5mm Length Ti-6Al-4V Alloy Partially Threaded 3.5mm Hex Head
47-2483-050-50	5.0mm Cortical Screw 50mm Length Ti-6Al-4V Alloy Partially Threaded 3.5mm Hex Head

47-2483-052-50	5.0mm Cortical Screw 52.5mm Length Ti-6Al-4V Alloy Partially Threaded 3.5mm Hex Head
47-2483-055-50	5.0mm Cortical Screw 55mm Length Ti-6Al-4V Alloy Partially Threaded 3.5mm Hex Head
47-2483-057-50	5.0mm Cortical Screw 57.5mm Length Ti-6Al-4V Alloy Partially Threaded 3.5mm Hex Head
47-2483-060-50	5.0mm Cortical Screw 60mm Length Ti-6Al-4V Alloy Partially Threaded 3.5mm Hex Head
47-2483-065-50	5.0mm Cortical Screw 65mm Length Ti-6Al-4V Alloy Partially Threaded 3.5mm Hex Head
47-2483-070-50	5.0mm Cortical Screw 70mm Length Ti-6Al-4V Alloy Partially Threaded 3.5mm Hex Head
47-2483-075-50	5.0mm Cortical Screw 75mm Length Ti-6Al-4V Alloy Partially Threaded 3.5mm Hex Head
47-2483-080-50	5.0mm Cortical Screw 80mm Length Ti-6Al-4V Alloy Partially Threaded 3.5mm Hex Head
47-2483-085-50	5.0mm Cortical Screw 85mm Length Ti-6Al-4V Alloy Partially Threaded 3.5mm Hex Head
47-2483-090-50	5.0mm Cortical Screw 90mm Length Ti-6Al-4V Alloy Partially Threaded 3.5mm Hex Head
47-2483-095-50	5.0mm Cortical Screw 95mm Length Ti-6Al-4V Alloy Partially Threaded 3.5mm Hex Head
47-2483-100-50	5.0mm Cortical Screw 100mm Length Ti-6Al-4V Alloy Partially Threaded 3.5mm Hex Head
47-2484-020-50	5.0mm Cortical Screw 20mm Length Ti-6Al-4V Alloy Fixed Angle 3.5mm Hex Head
47-2484-022-50	5.0mm Cortical Screw 22.5mm Length Ti-6Al-4V Alloy Fixed Angle 3.5mm Hex Head
47-2484-025-50	5.0mm Cortical Screw 25mm Length Ti-6Al-4V Alloy Fixed Angle 3.5mm Hex Head
47-2484-027-50	5.0mm Cortical Screw 27.5mm Length Ti-6Al-4V Alloy Fixed Angle 3.5mm Hex Head
47-2484-030-50	5.0mm Cortical Screw 30mm Length Ti-6Al-4V Alloy Fixed Angle 3.5mm Hex Head
47-2484-032-50	5.0mm Cortical Screw 32.5mm Length Ti-6Al-4V Alloy Fixed Angle 3.5mm Hex Head
47-2484-035-50	5.0mm Cortical Screw 35mm Length Ti-6Al-4V Alloy Fixed Angle 3.5mm Hex Head
47-2484-037-50	5.0mm Cortical Screw 37.5mm Length Ti-6Al-4V Alloy Fixed Angle 3.5mm Hex Head
47-2484-040-50	5.0mm Cortical Screw 40mm Length Ti-6Al-4V Alloy Fixed Angle 3.5mm Hex Head
47-2484-042-50	5.0mm Cortical Screw 42.5mm Length Ti-6Al-4V Alloy Fixed Angle 3.5mm Hex Head
47-2484-045-50	5.0mm Cortical Screw 45mm Length Ti-6Al-4V Alloy Fixed Angle 3.5mm Hex Head
47-2484-047-50	5.0mm Cortical Screw 47.5mm Length Ti-6Al-4V Alloy Fixed Angle 3.5mm Hex Head
47-2484-050-50	5.0mm Cortical Screw 50mm Length Ti-6Al-4V Alloy Fixed Angle 3.5mm Hex Head
47-2484-052-50	5.0mm Cortical Screw 52.5mm Length Ti-6Al-4V Alloy Fixed Angle 3.5mm Hex Head
47-2484-055-50	5.0mm Cortical Screw 55mm Length Ti-6Al-4V Alloy Fixed Angle 3.5mm Hex Head
47-2484-057-50	5.0mm Cortical Screw 57.5mm Length Ti-6Al-4V Alloy Fixed Angle 3.5mm Hex Head
47-2484-060-50	5.0mm Cortical Screw 60mm Length Ti-6Al-4V Alloy Fixed Angle 3.5mm Hex Head

47-2484-065-50	5.0mm Cortical Screw 65mm Length Ti-6Al-4V Alloy Fixed Angle 3.5mm Hex Head
47-2484-070-50	5.0mm Cortical Screw 70mm Length Ti-6Al-4V Alloy Fixed Angle 3.5mm Hex Head
47-2484-075-50	5.0mm Cortical Screw 75mm Length Ti-6Al-4V Alloy Fixed Angle 3.5mm Hex Head
47-2484-080-50	5.0mm Cortical Screw 80mm Length Ti-6Al-4V Alloy Fixed Angle 3.5mm Hex Head
47-2484-085-50	5.0mm Cortical Screw 85mm Length Ti-6Al-4V Alloy Fixed Angle 3.5mm Hex Head
47-2484-090-50	5.0mm Cortical Screw 90mm Length Ti-6Al-4V Alloy Fixed Angle 3.5mm Hex Head
47-2484-095-50	5.0mm Cortical Screw 95mm Length Ti-6Al-4V Alloy Fixed Angle 3.5mm Hex Head
47-2484-100-50	5.0mm Cortical Screw 100mm Length Ti-6Al-4V Alloy Fixed Angle 3.5mm Hex Head

### Nail Caps / Set Screw

Item Number	Product Description
47-2487-002-00	Cephalomedullary Nail Cap 0mm Height Ti-6Al-4V Alloy
47-2487-002-05	Cephalomedullary Nail Cap 5mm Height Ti-6Al-4V Alloy
47-2487-002-10	Cephalomedullary Nail Cap 10mm Height Ti-6Al-4V Alloy
47-2487-002-15	Cephalomedullary Nail Cap 15mm Height Ti-6Al-4V Alloy
47-2493-000-00	Cephalomedullary Nail Set Screw Ti-6Al-4V Alloy

## Instruments

### KT-2490-003-00 – STANDARD Cephalomedullary Nail Instrument Set

Item Number	Product Description	Qty
02.00020.049	Ratchet Wrench 11mm	1
00-2490-000-30	Nail Diameter Gauge	1
00-2490-000-33	Ruler	1
00-2490-000-34	Nail Length Gauge	1
00-2490-000-41	Hole Indicator	2
00-2490-003-00	Cephalomedullary Standard Targeting Guide	1
00-2490-003-02	Standard Cephalomedullary Connecting Bolt	2
00-2490-032-44	Long Cephalomedullary Lag Screw Reamer 3.2mm ID	1
00-2490-003-45	Cephalomedullary Lag Screw Stop Assembly	2
00-2490-032-48	Long Cephalomedullary Lag Screw Tap 3.2mm ID	1
00-2490-003-49	Cephalomedullary Lag Screw Compression Device	1
00-2490-003-50	Long Cephalomedullary Lag Screw Inserter	1
00-2490-003-51	Long Cephalomedullary Lag Screw Retaining Shaft	1
00-2490-010-00	Long Cannulated Awl	1
00-2490-010-01	Short Cannulated Awl	1
00-2490-012-00	Guide Wire Gripper	1
00-2490-012-30	3.0mm Threaded Pin By 305mm	3
00-2490-013-00	Entry Cannula	1
00-2490-013-01	Entry Cannula Starting Point Locator	1
00-2490-014-15	Cephalomedullary Tapered Reamer 15.5mm	1
00-2490-014-80	Entry Reamer 8mm	1
00-2490-017-00	Guide Wire Pusher	1
00-2490-024-00	Reduction Finger	1
00-2490-031-05	11mm Hex / Pin Wrench	2
00-2490-031-08	Cephalomedullary Connecting Bolt Inserter 8.0mm	1
00-2490-032-00	Impaction Head	1
00-2490-032-05	Slotted Mallet	1
00-2490-033-00	Slap Hammer Adapter	1
00-2490-035-03	Cephalomedullary Screwdriver, 3.5mm Hex	1
00-2490-035-07	Cephalomedullary Flexible Captured Set Screw Driver Standard	1
00-2490-035-40	Long Modular 3.5 Hex Screwdriver	2
00-2490-035-42	Captured Screwdriver 3.5 Hex- Long	1
00-2490-035-72	Captured Screwdriver 3.5 Hex- freehand	1
00-2490-035-75	Freehand Modular 3.5mm Hex Screwdriver	2
00-2490-040-10	Long Cephalomedullary Lag Screw Cannula	1
00-2490-042-10	Long Cephalomedullary Lag Screw Trocar	1
00-2490-040-80	Long Screw Cannula 8.0mm	1
00-2490-043-32	Long Cephalomedullary Lag Screw Pin Sleeve 3.2mm	1
00-2490-043-43	Long Drill Sleeve 4.3mm	1
00-2490-044-43	Calibrated Drill 4.3mm Long	2
00-2490-045-80	Long Screw Depth Gauge 8mm	1
00-2490-046-20	2.0mm Pin	2
00-2490-047-32	3.2mm Threaded Pin x 508mm	3
00-2490-046-32	Guide Pin Insertor/Extractor	1
00-2490-003-80	Long Cannulated Screw Depth Gauge	1
00-2490-050-01	Modular Handle AO	1
00-2490-050-02	Modular T-Handle	1
00-2490-070-00	Free Hand Targeting Wand	1
00-2490-073-00	Free Hand Targeting Depth Gauge	1
00-2490-074-00	Free Hand Tissue Protection Sleeve	1
00-2490-075-43	4.3mm Free Hand Drill 152.5mm	1
00-2490-080-00	Nail Cap Insertor	1
00-2490-080-03	Nail Cap Retaining Shaft	1
00-2490-090-11	Cephalomedullary Extraction Adapter Cannulated	1
00-5900-099-00	Generic Stackable Lid	2
00-2490-042-80	Long Screw Trocar	1

**Instrument Cases (Select both “Stainless Steel” or both “Stainless Steel and Aluminum” Cases)**

Item Number	Product Description	Qty
00-2490-037-50	Cephalomedullary Standard Case 1 Of 2 - Stainless Steel And Aluminum	1
00-2490-051-50	Cephalomedullary Standard Case 2 Of 2 - Stainless Steel And Aluminum	1
00-2490-037-00	Cephalomedullary Standard Case 1 Of 2 - Stainless Steel	1
00-2490-051-00	Cephalomedullary Standard Case 2 Of 2 - Stainless Steel	1

**Optional Instruments**

Item Number	Product Description	Qty
00-2490-014-03	Inner Channel Reamer	1
00-2490-014-04	Inner Channel Reamer Sleeve	1
00-2490-030-04	Standard Antirotation Pin	1
00-2490-003-10	Cephalomedullary Standard Modular Targeting Guide	1
00-2490-048-50	Long 5.0mm Tap	1
00-2490-041-04	Standard Double Barrel Cannula	1
00-2490-072-43	Free Hand Targeting Drill 4.3mm	2
00-2490-091-11	Cephalomedullary Extraction Rod - M11 Thread	1
00-2490-048-32	3.2mm Non-Threaded Pin x 508mm	3

**Ball Tip Guide Wire (available separately)**

Item Number	Product Description
00-2255-008-01	3.0mm Ball Tip Guide Wire 100cm
47-2255-008-01	3.0mm Ball Tip Guide Wire 100cm (Sterile)
00-2255-008-00	2.4mm Ball Tip Guide Wire 70cm
47-2255-008-00	2.4mm Ball Tip Guide Wire 70cm (Sterile)

**Tear Drop Guide Wire (available separately)**

Item Number	Product Description
47-2490-097-00	3.0mm x 100cm Tear Drop Guide Wire (Sterile)
47-2490-098-00	3.0mm x 70cm Tear Drop Guide Wire (Sterile)
47-2490-097-01	2.4mm x 100cm Tear Drop Guide Wire (Sterile)
47-2490-098-01	2.4mm x 70cm Tear Drop Guide Wire (Sterile)

**Surgical Technique - 97-2493-002-00****Wall Chart - 97-2493-003-00****X-ray Templates:****CM Short: 06.02075.000/97-2493-051-00 (US Only)****CM Long: 06.02087.000/97-2493-050-00 (US Only)**





This documentation is intended exclusively for physicians and is not intended for laypersons. Information on the products and procedures contained in this document is of a general nature and does not represent and does not constitute medical advice or recommendations. Because this information does not purport to constitute any diagnostic or therapeutic statement with regard to any individual medical case, each patient must be examined and advised individually, and this document does not replace the need for such examination and/or advice in whole or in part. Please refer to the package inserts for important product information, including, but not limited to, contraindications, warnings, precautions, and adverse effects.



Contact your Zimmer representative or visit us at [www.zimmer.com](http://www.zimmer.com)

The CE mark is valid only if it is also printed on the product label.

