

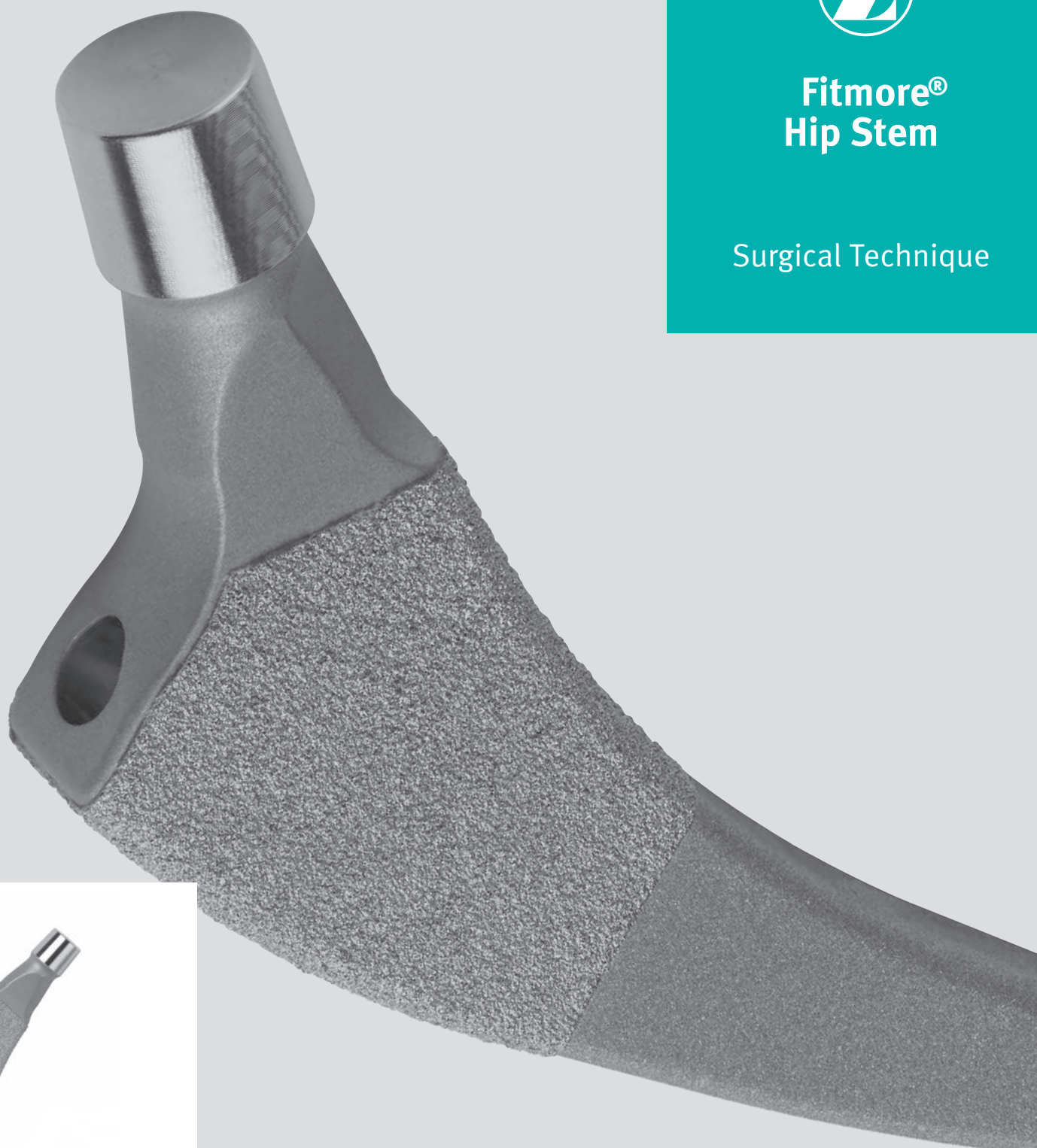

# Fitmore<sup>®</sup> Hip Stem

Surgical Technique



A New Concept in Bone Conservation





## Surgical Technique Fitmore Hip Stem

### Table of Contents

|   |           |
|---|-----------|
| Introduction/The Offset Options                   | 4         |
| General Information/Indications/Contraindications | 5         |
| <b>Preoperative Planning</b>                      | <b>6</b>  |
| The Primary Objectives of Preoperative Planning   | 6         |
| Positioning for X-rays                            | 6         |
| Templating the Acetabulum                         | 6         |
| Templating the Femur                              | 6         |
| <b>Planning Steps</b>                             | <b>7</b>  |
| Acetabular Component                              | 7         |
| Determination of the Stem Family                  | 8         |
| Equalizing Leg Length                             | 8         |
| Determination of the Size                         | 9         |
| Final Result                                      | 9         |
| <b>Surgical Technique</b>                         | <b>10</b> |
| Osteotomy of the Femoral Neck                     | 10        |
| Preparation of the Femoral Canal                  | 10        |
| Trial Reduction                                   | 12        |
| Insertion of the Fitmore Hip Stem                 | 13        |
| Intraoperative Extraction of the Fitmore Hip Stem | 14        |
| Exchangeable Plastic Jaws                         | 14        |
| <b>Postoperative Treatment</b>                    | <b>14</b> |
| <b>Fitmore Hip Stem Implants</b>                  | <b>15</b> |
| <b>Fitmore Hip Stem Instruments</b>               | <b>16</b> |

## Introduction

The *Fitmore* Hip Stem is a curved uncemented stem with a trapezoidal cross-section, which is coated proximally with Ti-VPS (Titanium Vacuum Plasma Spray) and rough-blasted distally.

The stem system is comprised of 3 stem families A, B and C (family B with two offsets), in order to cover different anatomies.

The anchorage is mainly metaphyseal, in the intertrochanteric region. The rasps and the corresponding implants are not inserted straight into the femoral canal, but rather along the calcar, so that the area of the greater trochanter and, therefore, the insertion of the gluteal muscles can be preserved.

The *Fitmore* Hip Stem is compatible with all *Zimmer*® MIS approaches, with the exception of the *Zimmer MIS 2-Incision™* approach, and with all traditional approaches.



## The Offset Options

The *Fitmore* Hip Stem offers a wide range of offset options to address a variety of anatomic offsets among individuals. Biomechanical characteristics such as the femoral offset and the leg length can be restored while achieving soft tissue balance around the hip joint.

The same surgical technique is used for implantation of the *Fitmore* Hip Stem family A, family B, family B-Extended and family C.

In most cases, the B families will be the appropriate choice because they fit in most femora and offer the possibility to accommodate a bigger offset (B and B-Extended options). The A family might be more suitable for hips with a small offset, whereas varus hips with long necks may be better treated with C family stems.

In order to preserve bone stock of the greater trochanter and to be MIS compatible the *Fitmore* Hip Stem offers:

1. A curved shape and trapezoidal cross-section for maximum rotational stability
2. A three-dimensional wedge shape and proximal Ti-VPS coating for press-fit fixation
3. Various medial curves to optimize proximal fit
4. Different offsets independent from stem size to accurately restore joint biomechanics

## General Information

- Indications and contraindications for the use of these components may be relative or absolute and must be carefully weighed against the patient's entire evaluation and the prognosis for possible alternative procedures
- Patient selection should be largely dependent on patient's age, general health, conditions of available bone stock, prior surgery and anticipated further surgeries. An implantation is generally only indicated for patients who have reached skeletal maturity

## Indications

- This femoral stem is for total or hemi hip arthroplasty and is indicated for the following conditions: Patient conditions of noninflammatory degenerative joint disease (NIDJD), e.g., avascular necrosis, osteoarthritis and inflammatory degenerative joint disease (IID), e.g., rheumatoid arthritis; those patients with failed previous surgery where pain, deformity, or dysfunction persists; revision of previously failed hip arthroplasty
- Total hip replacements may be considered for younger patients if any unequivocal indication outweighs the risks associated with the age of the patient and modified demands regarding activity and hip joint loading are assured. This includes severely crippled patients with multiple joint involvement, for whom an immediate need of hip mobility leads to an expectation of significant improvement in the quality of their lives
- This stem is for uncemented use

## Contraindications

- Patient's physical conditions that would eliminate or tend to eliminate adequate implant support or prevent the use of an appropriately sized implant, e. g., previous surgery, insufficient quality or quantity of bone resulting from conditions such as cancer or congenital dislocation, metabolic bone disease of the upper femur or pelvis, femoral osteotomy revision, girdlestone revision, osteoporosis, osteomyelitis, neuromuscular compromise or vascular deficiency in the affected limb in sufficient degree to render the procedure unjustifiable (e. g., absence of musculoligamentous supporting structures, joint neuropathy) or other conditions that may lead to inadequate skeletal fixation
- Active infection of the hip, old or remote infection. This may be an absolute or relative contraindication. Every effort should be undertaken to rule out preoperative infection in a patient with suspicious symptoms, such as a history of, or when there are signs of, local inflammation, abscesses, fever, increased blood sedimentation rate, evidence of rapid joint destruction or bone resorption
- Allergy to the implanted material, above all to metal (e. g. cobalt, chromium, nickel, etc.)
- Local bone tumors and/or cysts
- Pregnancy





## Preoperative Planning

It is important that the preoperative planning is made with the necessary accuracy and that the individual steps of the operation are followed exactly.

Although X-ray quality may vary, a carefully planned total hip replacement helps to minimize intraoperative complications.

### The Primary Objectives of Preoperative Planning are to

1. Determine preoperative leg length
2. Determine acetabular component size and position
3. Choose the family of the *Fitmore* Hip Stem by restoring offset, center of rotation and by matching the medial contour of the stem with the calcar arch
4. Determine femoral component size, position and fit

In addition, preoperative planning will assist in identifying bone deformities and potential problems that might require special instrumentation during surgery. In the event that adverse bone conditions are present, it is recommended to have a C-arm ready in the operating room in order to assess the implant position intraoperatively.

### Positioning for X-rays

For the AP X-ray of the pelvis, both femurs should be rotated internally until both patellae point straight anteriorly, to be able to assess the femoral neck length and offset. An axial view may also be helpful in determining implant size and version of the femur.

#### Considerations

- In a proper X-ray, it is possible to draw a continuous line from the femoral neck to the greater trochanter
- In external rotation contracture, it may be helpful to use the contralateral hip for planning

### Templating

#### There are four basic steps

- Determination of the position and orientation of the acetabular component
- Choice of the right family of the *Fitmore* hip stem
- Restoration of the leg length
- Choice the right size of the *Fitmore* Hip Stem

### Templating the Acetabulum

The primary objective of templating the acetabulum is to estimate the size of the acetabular component. Preoperative determination of the correct acetabular component size requires an X-ray of the affected hip in both AP and lateral views. The initial templating should start with the AP X-ray. Furthermore, component position with respect to inclination and anteversion of the cup is planned while achieving sufficient bony cup coverage. Finally, the amount of osteophytes necessary to remove to avoid impingement is estimated.

### Templating the Femur

The primary objective of templating the femur is to choose the appropriate family and size of the stem. It requires an X-ray of the entire pelvis, which includes the proximal third of the femur.

#### Choice of the appropriate family and size of the stem:

Three different families (A, B, C) of the *Fitmore* Hip Stem are shown on the overview template. With this template the most suitable family is determined by restoring anatomical offset and by confirming that the medial curve of this stem follows closely the inner line of the cortex in the calcar region when the stem is in axis with the femoral canal. After choosing the correct stem family with the help of the overview template, the appropriate size is selected using the family-specific templates. The width of the medullary canal determines the body size.

## Planning Steps

The preoperative planning determines the correct position and size of the acetabular and femoral component. The correct positioning of the acetabular and femoral components is mandatory in order to ensure optimal component fixation and restore hip biomechanics.

### Acetabular Component

The cup templates are placed on the X-ray with the acetabular component in approximately 40 to 45 degrees of inclination. Several sizes are assessed to determine which acetabular component will provide the optimal fit with maximum coverage. The anatomical center of rotation of the femoral head should be reproduced by the position of the acetabular component. The component that meets these requirements is selected. The tracing paper is placed on the X-ray and the template. The contour of the hemipelvis and the chosen cup are drawn on the tracing paper. Then the paper is removed.



### Determination of the Stem Family

Place the overview template on the pelvis X-ray. In the overview template, the three stem families are displayed with their smallest and biggest sizes. The correct family is chosen primarily based on the correct offset.

To choose the correct stem family, position the overview template of the family that seems most appropriate into the medullary canal so that the reference line of the femoral axis is parallel to the femur and that the medial contour of the prosthesis is aligned with the cortex. Now move the template up- or downward until the centers of rotation of the cup and the chosen stem family are in line (with the reference center line). If these centers overlap the selected stem family reproduces the offset correctly and you will continue your planning with this stem family. If the centers do not overlap, repeat the procedure with the other families until one family fits correctly representing the family of choice. Trace the medial outline of the selected stem family on the tracing paper.

### Equalizing Leg Length

Place the tracing paper on the opposite side with the cup and the medial contour of the stem aligned to the femur. The tips of the greater and lesser trochanters are drawn as reference for leg length.

Place the tracing paper again on the side to be operated. The drawn trochanters are placed in line with the trochanters of the side to be operated which automatically equalizes leg length in the planning. Be aware that the positioning of the pelvis on the tracing paper will reflect changes in leg length and may not be aligned with the x-ray during the remaining steps. The inner and outer contours of the femur are outlined.

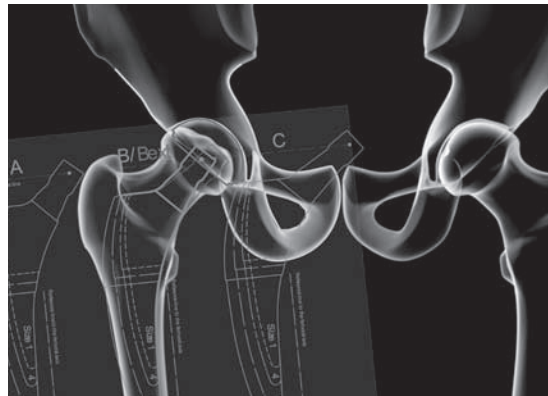



### Determination of the Size

Take the sizing templates of the selected stem family, place its medial contour accurately on the previously drawn contour and increase the size starting with size one until the stem fills the medullary canal, i.e. the lateral side of the stem touches the lateral cortex. It is very important that the axis of the stem shown on the template is parallel to the femoral axis. The stem that fits best completes the drawing of the contour of the optimal stem on the tracing paper.



### Final Result

The distance between the proximal end of the stem taper and the lesser trochanter is measured and written down. Other reference marks may be used depending on the individual technique and can be measured as well, for example the distance between the tip of the greater trochanter and the shoulder of the prosthesis. Finally, all necessary information about the patient and the prosthetic components is written down.

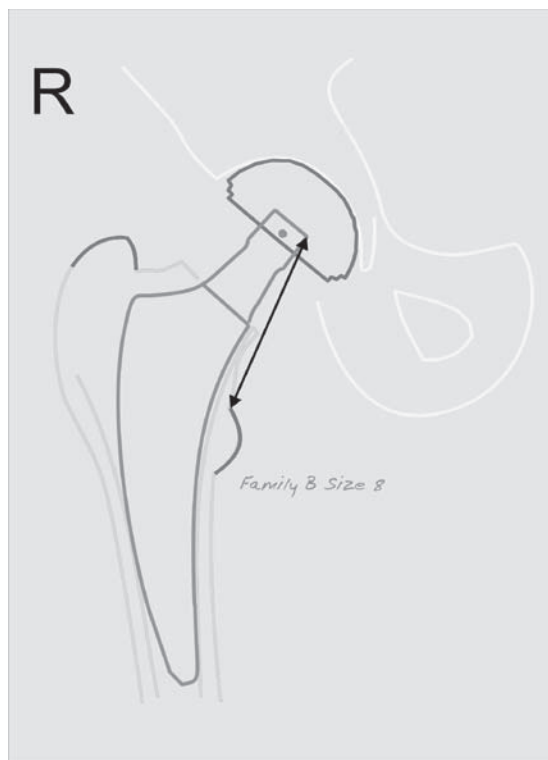

## Surgical Technique

This surgical technique may be adapted to the surgeon's specific approach. The following description of the surgical technique starts with the osteotomy of the femoral neck.

### Osteotomy of the Femoral Neck

The *Fitmore* Hip Stem instrument set simplifies the surgery and allows a well-targeted and efficient operating procedure. The osteotomy typically starts at the base of the femoral neck and is inclined by 45°. Depending on the planning and the individual anatomy the osteotomy may vary in height.

### Preparation of the Femoral Canal

The femoral canal is entered by opening the medullary canal with a starter instrument (curved chisel or curved hand rasp) which enters into the resection surface on the posterior side, in the middle third, and should be in line with the axis of the femur.

It is recommended to direct the entry point towards the medullary canal following the axis of the femur. This will ensure the correct introduction of the starter instrument (curved hand rasp or curved chisel) and the subsequent starter rasp. The starter instrument should only be inserted and not twisted in the cancellous bone. Care must be taken to preserve as much bone as possible. **The use of an awl is not recommended.**

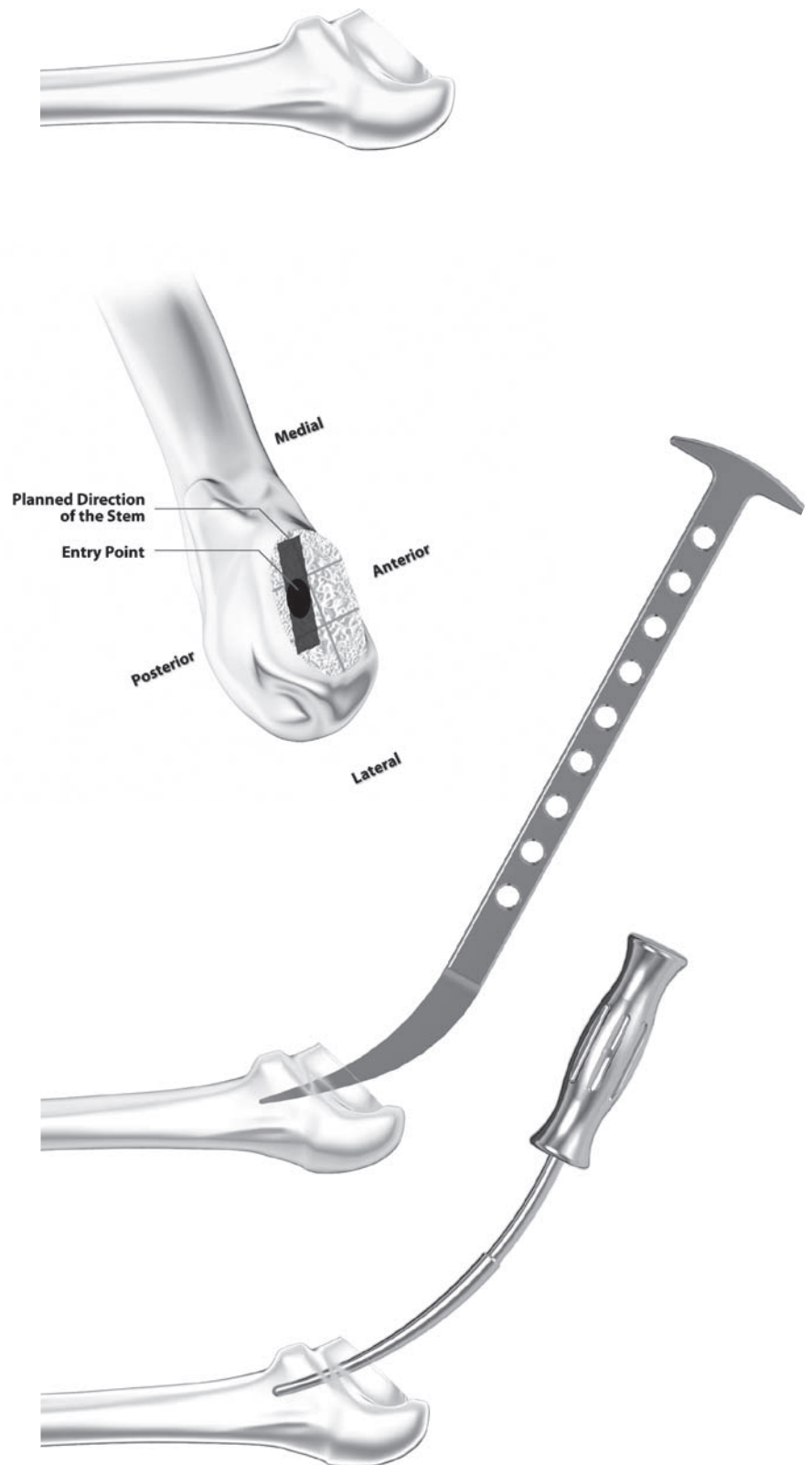

Prepare the femoral canal by first using the starter rasp to enter the medullary canal.

Start with the smallest rasp size of the stem family chosen in the preoperative planning. The insertion of the first rasp will determine the anteversion of the subsequent rasps and the final implant.

The femoral canal is prepared, using rasps of increasing size, until maximum stability is obtained usually with the preoperatively determined stem size. If the medial fit of the rasp is not adequate, i.e. there is no cortical contact in the calcar region, one should consider switching from stem family A to B or from stem family B to C. In this case it is recommended to start rasping two sizes smaller than the last rasp size used.

**Example:** If the last rasp used was A8, start again with rasp B6.

It must be taken into consideration that by changing the stem family the offset is also changed. Therefore, the new stem family and the preoperatively planned stem height (to the references chosen on the preoperative planning) need to be reassessed in order to avoid lengthening the leg. In most cases switching families means downsizing one to two sizes within the new stem family.

#### Tip

If, based on the X-rays, one is not certain which family is best, then start with family A. Then the offset could be increased gradually from stem family A to B and then from B to C, but not directly from A to C. It is only allowed to switch from a smaller offset prosthesis to a bigger, which means from family A to B, or B to C. But do not switch from family A directly to family C. The order A to B and B to C must always be maintained.

#### Warning

**Never switch from C to B, or C to A, or B to A.**



### Trial Reduction

Remove the rasp handle and leave the rasp in the femoral canal. Choose the appropriate trial neck following the stem family concept, i.e. A, B, B-Ext. or C. The stem families are indicated on the top of the trial necks. Each rasp family has a specific design coding feature to prevent incorrect rasp body and trial neck mating. Please be aware that only stem family B has two different offset options (B and B-Ext.) on the same rasp body. Once the trial neck is inserted, check the distance between lesser trochanter and taper compared with your preoperative planning. If the distance is according to the preoperative planning the adequate trial head is used for trial reduction.

Joint stability and soft-tissue tension are assessed. This procedure is repeated as necessary, using trial heads of different lengths, until optimal offset, leg length and stability are achieved. A trial reduction should not allow significant push-pull of the joint in full extension. The range of motion is checked to avoid bony and implant impingement as well as instability.



### Color Coding and Labeling

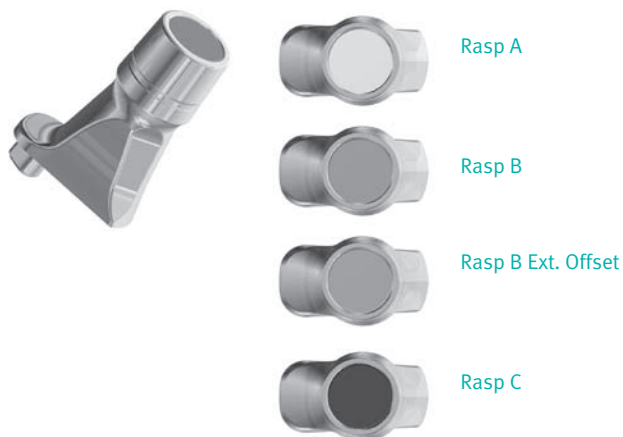

### Design Coding



### Insertion of the Fitmore Hip Stem

After removal of the rasp, the selected stem is inserted and driven in until cortical contact stabilizes the stem.

It is important to adjust the force of the mallet blows to the quality of the bone and to stop immediately when the dull sound (cancellous bone) changes to the sharp sound (cortical bone).

After driving in the stem, the taper protector is removed from the taper and a trial head may be mounted for a final trial head reduction. Once the final range of motion and “shuck” tests are completed, the taper is carefully cleaned and dried. The selected femoral head is mounted with a rotational movement and rotated further with axial force until it is firmly seated. The femoral head is seated with one light mallet blow on the head impactor in an axial direction. After reduction of the joint, the range of motion and the stability of the joint are reassessed throughout the whole range of motion.

Wound closure is carried out according to the specific technique and approach used.



### Intraoperative Extraction of the Fitmore Hip Stem

If the stem needs to be removed intraoperatively, only the specific extraction instrument, which protects the taper of the stem, may be used. Slide the extraction instrument over the stem taper. Tighten the exchangeable plastic jaws by closing the lever. Make sure that the instrument is firmly fixed. Remove the stem by hammering back on the extraction instrument.

#### Important

The extraction instrument must be used exclusively for intraoperative stem extraction. It is not suitable for revision cases. The plastic jaws can be exchanged, if necessary. In case of intraoperative repositioning of the stem the surgeon must verify the integrity of the stem.



### Exchangeable Plastic Jaws

#### Insertion of the Plastic Jaw

Each plastic jaw is aligned with the slot and snapped in place inside the housing.

#### Exchange of the Plastic Jaws

A pin is used through the hole to release the plastic jaws.

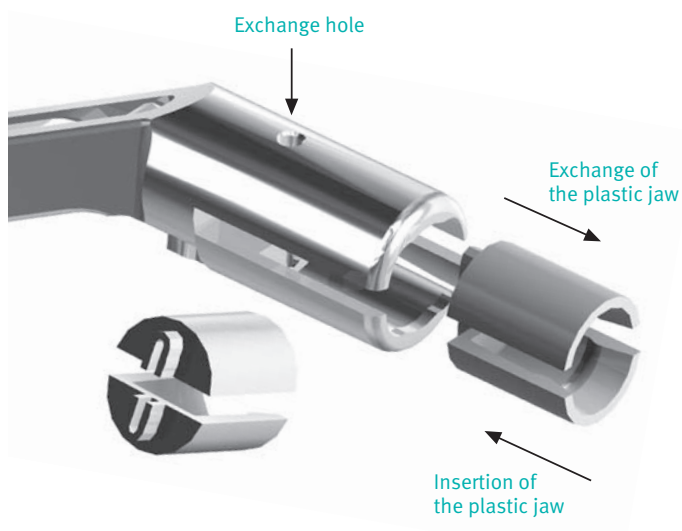

### Postoperative Treatment

The postoperative treatment depends on the patient and the bone quality. Immediate weight bearing can be allowed in agreement with the orthopedic surgeon and mobilization may be started on the first postoperative day depending on the individual rehabilitation protocol. Crutches should be used until the patient is able to walk safely without limping.



## Fitmore Hip Stem Implants

### Fitmore Hip Stem A, 140°



Details  
Protasul®-64 Alloy  
Taper 12/14  
uncemented  
**STERILE R**

| Dimensions | Offset | REF          |         |       |                |
|------------|--------|--------------|---------|-------|----------------|
| Size 2     | 31.50  | 01.00551.102 | Size 9  | 35.50 | 01.00551.109   |
| Size 3     | 32.00  | 01.00551.103 | Size 10 | 36.25 | 01.00551.110   |
| Size 4     | 32.50  | 01.00551.104 | Size 11 | 37.00 | 01.00551.111   |
| Size 5     | 33.00  | 01.00551.105 | Size 12 | 37.75 | 01.00551.112   |
| Size 6     | 33.62  | 01.00551.106 | Size 13 | 38.50 | 01.00551.113** |
| Size 7     | 34.25  | 01.00551.107 | Size 14 | 39.25 | 01.00551.114** |
| Size 8     | 34.88  | 01.00551.108 |         |       |                |

### Fitmore Hip Stem B, 137°



Details  
Protasul®-64 Alloy  
Taper 12/14  
uncemented  
**STERILE R**

| Dimensions | Offset | REF          |         |       |                |
|------------|--------|--------------|---------|-------|----------------|
| Size 1     | 37.00  | 01.00551.201 | Size 8  | 40.88 | 01.00551.208   |
| Size 2     | 37.50  | 01.00551.202 | Size 9  | 41.50 | 01.00551.209   |
| Size 3     | 38.00  | 01.00551.203 | Size 10 | 42.25 | 01.00551.210   |
| Size 4     | 38.50  | 01.00551.204 | Size 11 | 43.00 | 01.00551.211   |
| Size 5     | 39.00  | 01.00551.205 | Size 12 | 43.75 | 01.00551.212   |
| Size 6     | 39.62  | 01.00551.206 | Size 13 | 44.50 | 01.00551.213** |
| Size 7     | 40.25  | 01.00551.207 | Size 14 | 45.25 | 01.00551.214** |

### Fitmore B Ext. Offset, 129°



Details  
Protasul®-64 Alloy  
Taper 12/14  
uncemented  
**STERILE R**

| Dimensions | Offset | REF          |         |       |                |
|------------|--------|--------------|---------|-------|----------------|
| Size 1     | 44.00  | 01.00551.301 | Size 8  | 47.88 | 01.00551.308   |
| Size 2     | 44.50  | 01.00551.302 | Size 9  | 48.50 | 01.00551.309   |
| Size 3     | 45.00  | 01.00551.303 | Size 10 | 49.25 | 01.00551.310   |
| Size 4     | 45.50  | 01.00551.304 | Size 11 | 50.00 | 01.00551.311   |
| Size 5     | 46.00  | 01.00551.305 | Size 12 | 50.75 | 01.00551.312   |
| Size 6     | 46.62  | 01.00551.306 | Size 13 | 51.50 | 01.00551.313** |
| Size 7     | 47.25  | 01.00551.307 | Size 14 | 52.25 | 01.00551.314** |

### Fitmore Hip Stem C, 127°



Details  
Protasul®-64 Alloy  
Taper 12/14  
uncemented  
**STERILE R**

| Dimensions | Offset | REF          |         |       |                |
|------------|--------|--------------|---------|-------|----------------|
| Size 1     | 51.00  | 01.00551.401 | Size 8  | 54.88 | 01.00551.408   |
| Size 2     | 51.50  | 01.00551.402 | Size 9  | 55.50 | 01.00551.409   |
| Size 3     | 52.00  | 01.00551.403 | Size 10 | 56.25 | 01.00551.410   |
| Size 4     | 52.50  | 01.00551.404 | Size 11 | 57.00 | 01.00551.411   |
| Size 5     | 53.00  | 01.00551.405 | Size 12 | 57.75 | 01.00551.412   |
| Size 6     | 53.62  | 01.00551.406 | Size 13 | 58.50 | 01.00551.413** |
| Size 7     | 54.25  | 01.00551.407 | Size 14 | 59.25 | 01.00551.414** |

\*\* Available upon request

## Fitmore Hip Stem Instruments

### Fitmore Rasp Set A

Fitmore Rasp Set A  
(complete set with all instruments)

REF  
KT-0055-910-01

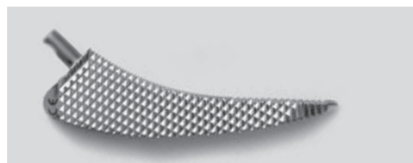

Fitmore Rasp Tray A

REF  
00-7895-061-00

Lid

REF  
00-5900-099-00

Fitmore Rasp A

| Description | Quantity | REF            |
|-------------|----------|----------------|
| Size 1      | 1        | 01.00559.101   |
| Size 2      | 1        | 01.00559.102   |
| Size 3      | 1        | 01.00559.103   |
| Size 4      | 1        | 01.00559.104   |
| Size 5      | 1        | 01.00559.105   |
| Size 6      | 1        | 01.00559.106   |
| Size 7      | 1        | 01.00559.107   |
| Size 8      | 1        | 01.00559.108   |
| Size 9      | 1        | 01.00559.109   |
| Size 10     | 1        | 01.00559.110   |
| Size 11     | 1        | 01.00559.111   |
| Size 12     | 1        | 01.00559.112   |
| Size 13     | 1        | 01.00559.113** |
| Size 14     | 1        | 01.00559.114** |



Fitmore Trial Neck A, 140°

Quantity REF  
1 01.00559.150

### Fitmore Rasp Set B

Fitmore Rasp Set B  
(complete set with all instruments)

REF  
KT-0055-910-02

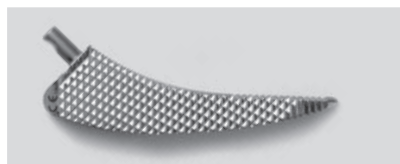

Fitmore Rasp Tray B

REF  
00-7895-063-00

Lid

REF  
00-5900-099-00

Fitmore Rasp B

| Description | Quantity | REF            |
|-------------|----------|----------------|
| Size 1      | 1        | 01.00559.201   |
| Size 2      | 1        | 01.00559.202   |
| Size 3      | 1        | 01.00559.203   |
| Size 4      | 1        | 01.00559.204   |
| Size 5      | 1        | 01.00559.205   |
| Size 6      | 1        | 01.00559.206   |
| Size 7      | 1        | 01.00559.207   |
| Size 8      | 1        | 01.00559.208   |
| Size 9      | 1        | 01.00559.209   |
| Size 10     | 1        | 01.00559.210   |
| Size 11     | 1        | 01.00559.211   |
| Size 12     | 1        | 01.00559.212   |
| Size 13     | 1        | 01.00559.213** |
| Size 14     | 1        | 01.00559.214** |



Fitmore Trial Neck B, 137°

Quantity REF  
1 01.00559.250



Fitmore Trial Neck B Ext. Offset, 129°

Quantity REF  
1 01.00559.251

\*\*Available upon request

### Fitmore Rasp Set C

Fitmore Rasp Set C  
(complete set with all instruments)

REF  
KT-0055-910-03

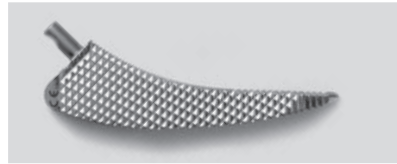

Fitmore Trial Neck C, 127°

Fitmore Rasp Tray C

REF  
00-7895-065-00

Fitmore Rasp C

| Description | Quantity | REF            |
|-------------|----------|----------------|
| Size 1      | 1        | 01.00559.301   |
| Size 2      | 1        | 01.00559.302   |
| Size 3      | 1        | 01.00559.303   |
| Size 4      | 1        | 01.00559.304   |
| Size 5      | 1        | 01.00559.305   |
| Size 6      | 1        | 01.00559.306   |
| Size 7      | 1        | 01.00559.307   |
| Size 8      | 1        | 01.00559.308   |
| Size 9      | 1        | 01.00559.309   |
| Size 10     | 1        | 01.00559.310   |
| Size 11     | 1        | 01.00559.311   |
| Size 12     | 1        | 01.00559.312   |
| Size 13     | 1        | 01.00559.313** |
| Size 14     | 1        | 01.00559.314** |

Quantity REF  
1 01.00559.350

Lid

REF  
00-5900-099-00

\*\*Available upon request

## Fitmore General Instrument Set

*Fitmore* General Set (complete set with all instruments)

REF  
KT-0055-910-00



*Fitmore* Curved Hand Rasp

Quantity REF  
1 00-7942-020-00



*Fitmore* Intra-Operative Extraction Instrument

Quantity REF  
1 01.00559.620

*Fitmore* Base Tray General Instruments

REF  
00-7895-067-00



*Fitmore* Curved Chisel

Quantity REF  
1 01.00559.630



MIS Double Offset Rasp Handle 45°

Quantity REF  
1 Left 00-7712-035-01  
1 Right 00-7712-035-02

*Fitmore* Tray Insert General Instruments

REF  
00-7895-068-00

Lid

REF  
00-5900-099-00



*Fitmore* Starter Rasp

Quantity REF  
1 01.00559.610



Straight Rasp Handle 45°

| Quantity | REF            |
|----------|----------------|
| 1        | 00-7712-050-60 |



Modular Repositioning Handle, short

| Quantity | REF         |
|----------|-------------|
| 1        | 75.11.00-02 |



Repositioning Top

| Size  | Quantity | REF         |
|-------|----------|-------------|
| 28 mm | 1        | 78.00.38-28 |
| 32 mm | 1        | 78.00.38-32 |
| 36 mm | 1        | 78.00.38-36 |



Ball-Head Impactor Attachment

| Quantity | REF      |
|----------|----------|
| 1        | 78.00.38 |



MIS Osteotomy Guide 45°

| Quantity | REF            |
|----------|----------------|
| 1        | 00-7806-009-45 |



Femoral head provisionals

| Size          | Quantity | REF            |
|---------------|----------|----------------|
| 28 mm (-3.5)  | 1        | 00-7895-028-01 |
| 28 mm (+0)    | 1        | 00-7895-028-02 |
| 28 mm (+3.5)  | 1        | 00-7895-028-03 |
| 28 mm (+7.0)  | 1        | 00-7803-028-14 |
| 28 mm (+10.5) | 1        | 00-7895-028-05 |
| 32 mm (-3.5)  | 1        | 00-7895-032-01 |
| 32 mm (+0)    | 1        | 00-7895-032-02 |
| 32 mm (+3.5)  | 1        | 00-7895-032-03 |
| 32 mm (+7.0)  | 1        | 00-7803-032-14 |
| 32 mm (+10.5) | 1        | 00-7895-032-05 |
| 36 mm (-3.5)  | 1        | 00-7895-036-01 |
| 36 mm (+0)    | 1        | 00-7895-036-02 |
| 36 mm (+3.5)  | 1        | 00-7895-036-03 |
| 36 mm (+7.0)  | 1        | 00-7895-036-04 |
| 36 mm (+10.5) | 1        | 00-7895-036-05 |



Stem Driver (offset with teardrop-tip)

| Quantity | REF            |
|----------|----------------|
| 1        | 00-7712-057-10 |

## Upon Request



Stem Driver (with locking mechanism)

| Quantity | REF            |
|----------|----------------|
| 1        | 00-7712-056-00 |



Calcar Planer

| Quantity | Size  | REF            |
|----------|-------|----------------|
| 1        | small | 00-7942-023-00 |
| 1        | large | 00-7942-025-00 |



Stem Driver (straight with teardrop tip)

| Quantity | REF            |
|----------|----------------|
| 1        | 00-7712-057-00 |

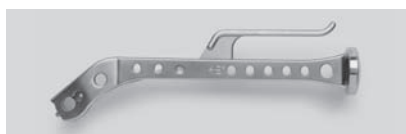

MIS Anterior Offset Rasp Handle 45°

| Quantity | REF            |
|----------|----------------|
| 1        | 00-7806-050-00 |



Plastic Jaws for REF 01.00559.620

| Quantity | REF              |
|----------|------------------|
| 1        | 01.00559.621* ** |



TM Primary Rasp Handle 23.5°

| Quantity | REF            |
|----------|----------------|
| 1        | 00-7865-035-20 |



Stem Driver (straight with round tip)

| Quantity | REF            |
|----------|----------------|
| 1        | 00-7712-064-00 |

\* Reusable

\*\* Available upon request









Please refer to package insert for complete product information, including contraindications, warnings, precautions, and adverse effects.

Contact your Zimmer representative or visit us at [www.zimmer.com](http://www.zimmer.com)



+H124970551002001/\$081203E09\$

97-0551-002-00 0810-H05 4.2ML Printed in USA ©2008 ,2009 Zimmer, Inc.