

14 mm x +30 mm Stem Extension

Persona® The Personalized Knee

Surgical Technique



Table of Contents

| | |
|---|-----------|
| Introduction | 2 |
| Preoperative Planning | |
| Surgical Approach | |
| Patient Preparation | |
| Magnet Usage | |
| Symbols | |
| Screw/Pin Information | |
| Sizing and Drilling of the Tibia | 4 |
| Resect Proximal Tibia | |
| Establish Size and Rotation of Tibia | |
| Drill the Tibia | |
| Sizing and Drilling of the Tibia (Alternative Technique) | 8 |
| Broaching the Tibia..... | 10 |
| Provisional Assembly and Trialing | 12 |
| Assembling the Tapered Stem Provisional to the Stemmed Tibial Provisional | |
| Using the Stemmed Tibial Provisional Construct | |
| Inserting the Stem into the Implant | 14 |
| Preparing the Tibial Stem Extension | |
| Implant Components | 16 |
| Tibial Plate | |

Introduction

Successful total knee arthroplasty depends in part on re-establishment of normal lower extremity alignment, proper implant design and orientation, secure implant fixation, and adequate soft tissue balancing and stability. Persona The Personalized Knee is designed to help the surgeon accomplish these goals by combining alignment accuracy with a simple, straight-forward technique.

The instruments and technique assist the surgeon in restoring the center of the hip, knee, and ankle to lie in a straight line, establishing a neutral mechanical axis. The femoral and tibial components are oriented perpendicular to this axis. Femoral rotation is determined using the posterior condyles, the epicondylar axis, or Whiteside's line as a reference. The instruments enable accurate cuts to ensure robust component fixation.

A wide variety of component sizes, shapes, and constraint options allow for optimized component fit and soft tissue balancing. The femur, tibia, and patella are prepared independently and can be cut in any sequence using the principle of measured resection (removing enough bone to allow replacement by the prosthesis). Adjustment cuts may be needed later. The anterior referencing technique uses the anterior cortex to set the A/P position of the femoral component. The posterior condyle cut is variable.

Additional technique steps are found in the Persona Knee Surgical Technique (97-5026-001-00) and the Persona CPS Surgical Technique (97-5026-072-00). The Persona 14 mm x +30 mm Stem Extension Surgical Technique is only to be used when utilizing the 14 mm x +30 mm extension with Persona Knee Implants and is not for general use with other Zimmer Biomet Knee Systems, such as NexGen® Knee, or Natural-Knee® II Systems.

See the Persona Knee Surgical Technique for the available implant constraint options.

Preoperative Planning

Obtain 36 inch or 53 inch standing anteroposterior and lateral radiographs of the extremity, as well as a sunrise view of the patella.

The entire femur should be visualized to rule out any structural abnormalities, as the distal femoral cut will be referenced from an intramedullary rod in the medullary canal.



Template (97-5026-051-00 includes the 14 mm x +30 mm stem extension) the patient's long-standing film to determine the angle between the anatomic axis and the mechanical axis. This angle will be reproduced intraoperatively. This surgical technique helps the surgeon ensure that the distal femur will be cut perpendicular to the mechanical axis and, after soft tissue balancing, will be parallel to the resected surface of the proximal tibia.

Surgical Approach

The surgeon can choose a midvastus approach, a subvastus approach, or a parapatellar medial arthrotomy. Also, depending on surgeon preference, the patella can be either everted or subluxed. The femur, tibia, and patella are prepared independently, and can be cut in any sequence using the principle of measured resection or gap balancing.

Patient Preparation

To prepare the limb for total knee arthroplasty, adequate muscle relaxation is required. The anesthesiologist should adjust the medication based on the patient's habitus and weight, and administer to induce adequate muscle paralysis for a minimum of 30-40 minutes. It is imperative that the muscle relaxant be injected prior to inflation of the tourniquet. Alternatively, spinal or epidural anesthesia should produce adequate muscle relaxation. If desired, apply a proximal thigh tourniquet and inflate it with the knee in hyperflexion to maximize that portion of the quadriceps that is below the level of the tourniquet. Once the patient is draped and prepped on the operating table, determine the landmarks for the surgical incision.

Magnet Usage

Warning: Some instruments in the Persona System contain magnets. All Persona magnetic instruments should be kept at a safe distance from a patient’s active implantable medical device(s) (i.e. pacemaker). These types of devices may be adversely affected by magnets. Instruments containing magnets should be kept on an appropriate table or stand when not in use at the surgical site.

Symbols

Symbols have been established for the following:

- Left
- Right
- Varus/Valgus
- Medial/Lateral
- Standard
- Do not implant – Not for implant
- Lock
- Unlock
- Anterior Referencing
- Do not impact
- Cemented
- Stemmed
- Inset Only

Screw/Pin Information

The chart below contains relevant information on various 3.2 mm screws/pins that are compatible with the Persona System. If these screws/pins are used during the procedure for instrument fixation, they should be removed prior to closure as they are NOT implantable.

Note: The 2.5 mm female hex screws and 2.5 mm male hex driver should not be used in cortical bone, as this may increase the incidence of stripping of the driver.

| Screw/Pin | Screw/Pin Item # | Compatible Driver | Shipped Sterile/ Non-sterile | Quantity per Package | Single use? |
|---|--|--|------------------------------|----------------------|-------------|
|  | 25 mm x 2.5 mm Female Hex Screw 42-5099-025-25* |  2.5 mm Male Hex Driver 42-5099-025-00 | Sterile | 2 | Yes |
|  | 75 mm x 3.2 mm Trocar Tipped Drill Pin (2.5 mm hex) 00-5901-020-00 |  Pin/Screw Insertor 00-5901-021-00 | Sterile | 4 | Yes |
|  | Hex Headed Screw 33 mm long 00-5901-035-33 | | Sterile | 2 | Yes |
|  | MIS Quad-Sparing Total Knee Headed Screw 48 mm long 00-5983-040-48 |  Screw Insertor/Extractor 00-5983-049-00 | Sterile | 1 | Yes |
|  | 25 mm Shorthead Holding Pin 00-5977-056-03 |  Multi Pin Puller 00-5901-022-00 | Non-Sterile | 1 | No |

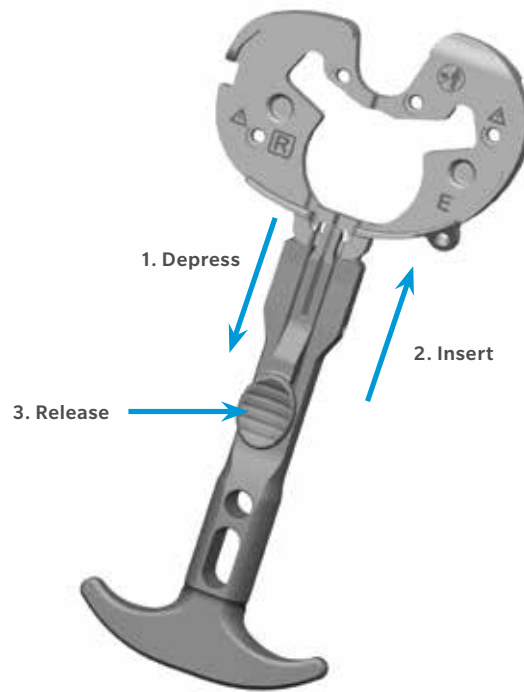

Figure 1

Sizing and Drilling of the Tibia

Resect Proximal Tibia

See *Persona Knee Surgical Technique* (97-5026-001-00).

Establish Size and Rotation of Tibia

Use only Persona tibial sizing, broaching, and provisional instrumentation for preparation of Persona Implants.

Once tibial osteophytes have been thoroughly removed, select the appropriate right or left sizing plate that provides the desired tibial coverage, without overhang at any location. Appropriate tibial sizing is important as an over sized tibial component can result in overhang, soft tissue impingement and pain, or with

stemmed components potential distal conflict between stem and bone.

Attach the tibial sizing plate handle to the cemented tibial sizing plate (Figure 1). The recommended tibial rotational alignment is within 5 degrees of the axis created by the medial 1/3 of the tibial tubercle and the PCL attachment point. The engraved lines on the cemented tibial sizing plate can be used to aid in establishing the desired tibial rotation. Rotate the cemented tibial sizing plate to attain the desired tibial rotational alignment. The notch in the lateral periphery of the sizing plate is used to establish proper position with respect to the lateral border of the tibia without medialization of the sizing plate.









| | | | | | | |
|---|---|---|---|---|---|---|
| Persona Tibial Sizing Plate Handle 42-5399-017-00 | Persona Cemented Tibial Sizing Plate Size F Right 42-5399-075-02 | Multi Pin Puller 00-5901-022-00 | Alignment Rod with Coupler 00-5785-080-00 | 2.5 mm Male Hex Driver 42-5099-025-00 | 25 mm x 2.5 mm Female Hex Screw 42-5099-025-25 | 25 mm Shorthead Holding Pin 00-5977-056-03 |
|  |  |  |  |  |  |  |



Figure 2

 Male-headed screws/pins must be removed from these holes for Tibial Articular Surface Provisionals (TASP)

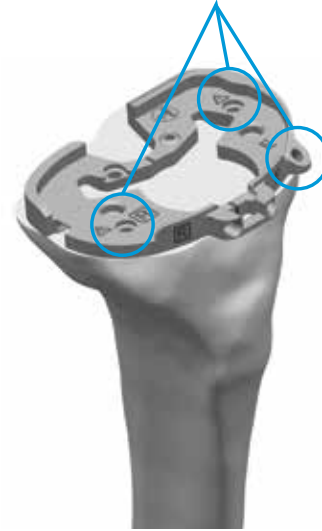



Figure 3

Sizing and Drilling of the Tibia (cont.)

Establish Size and Rotation of Tibia (cont.)

When the desired position has been attained, secure the cemented tibial sizing plate by placing 25 mm x 2.5 mm (2.5 mm female hex) screws or 25 mm shorthead holding pin(s) in the medial and lateral holes near the PCL cutout of the cemented tibial sizing plate (Figure 2). The remaining adjunct fixation holes shown on the surface of the cemented tibial sizing plate can be used if necessary. If the cemented tibial sizing plate is to be used as a provisional in later steps, male-headed screws/pins used in these holes must be removed prior to using the tibial articular surface provisionals (TASPs) (Figure 3). Ensure that the cemented tibial sizing plate remains in the proper position when securing it to the bone. Once desired alignment has been verified with the alignment rod, remove the tibial sizing plate handle from the cemented tibial sizing plate.

-  **Technique Tip:** Do not impact, lever, or pry the tibial sizing plate handle; this instrument is designed for alignment purposes only. Use the alignment rod in the hole or slot in the tibial sizing plate handle to verify proper tibial plate varus/valgus alignment. (See Appendix A in 97-5026-001-00 for correcting varus/valgus resections.)
-  **Technique Tip:** if using a screw through the anterior medial hole on the periphery of the cemented tibial sizing plate, ensure that the cemented tibial sizing plate remains in the desired position and does not lift off posteriorly.

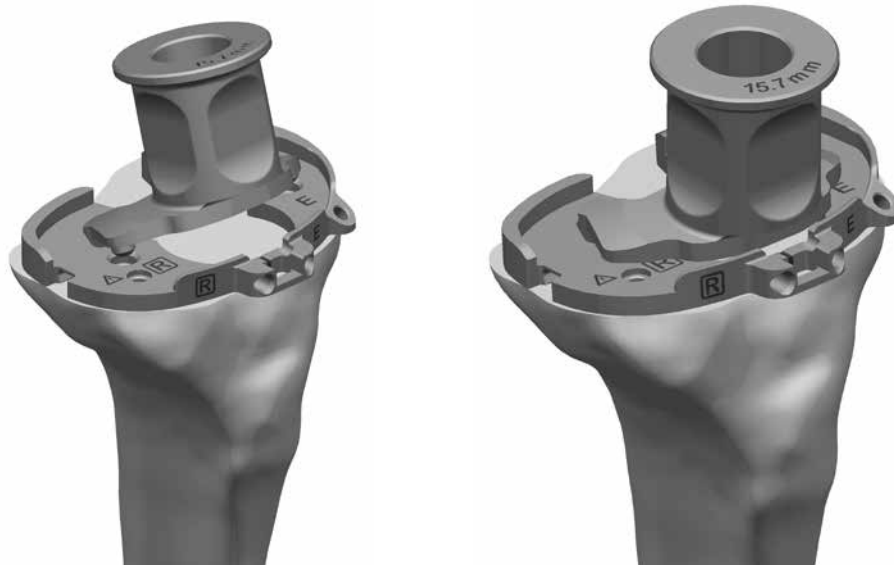

Figure 4

Sizing and Drilling of the Tibia (cont.)

Drilling the Tibia

The keel of the tibial implant has a unique location for every size; therefore it is critical to select the proper size at this step, before drilling and broaching. Once these subsequent steps have been performed, the size should not be changed. If desired, femoral finishing can be performed in conjunction with provisional trialing at this stage to assure that the desired range of motion and soft tissue balance can be attained with the cemented tibial sizing plate in place prior to drilling and broaching the tibia.

By hand, place and hold the cemented tibial drill guide on the tibia cemented tibial sizing plate, by first engaging the posterior tabs in the undercuts in the cemented tibial sizing plate and then making sure that the distal anterior portion of the cemented tibial drill guide is flush against the cemented tibial sizing plate (Figure 4).

Persona 14 mm x
+30 mm, 15.7 mm
Diameter Tibial Drill
42-5399-018-14

Persona Cemented
Tibial Drill Guide -
15.7 mm
42-5399-020-00

Persona Cemented Tibial Sizing Plate
Size F Right
42-5399-075-02



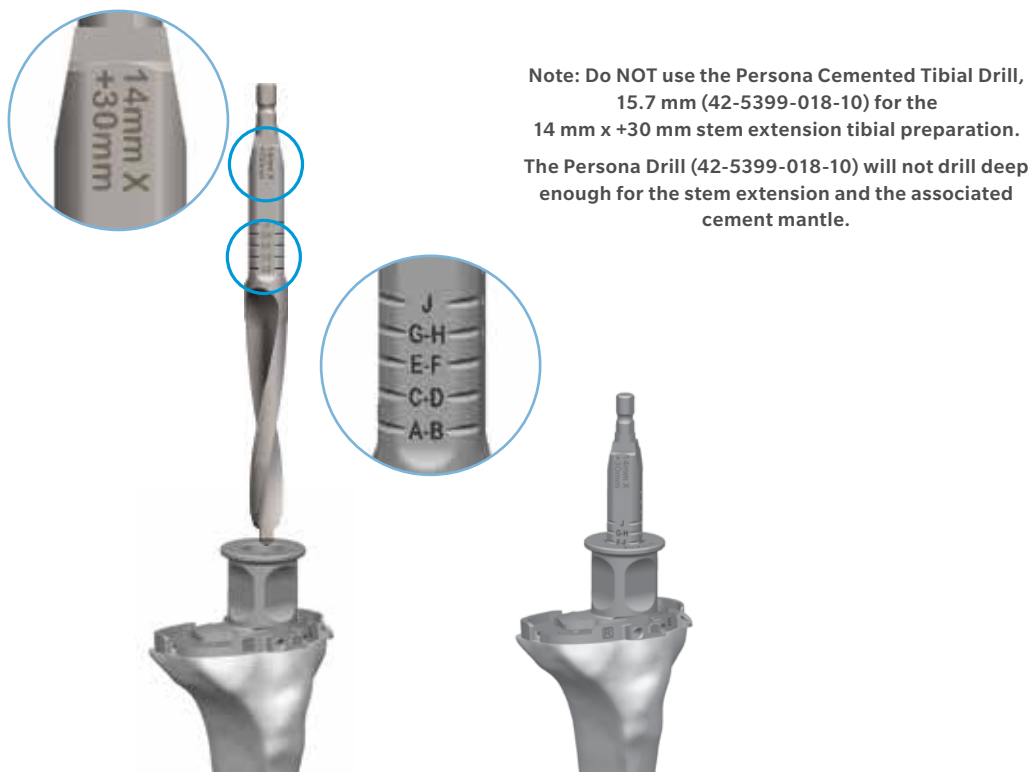

Figure 5

Sizing and Drilling of the Tibia (cont.)

Drilling the Tibia (cont.)

ⓘ **Note:** The drill to be utilized for the Persona 14 mm x +30 mm Tapered Stem Extension is different than the current Persona Tibial Drill (42-5399-018-10). Do NOT use the Persona Primary Tibial Drill (42-5399-018-10) to prepare the canal for the 14 mm x +30 mm tapered stem. The Persona Drill (42-5399-018-10) will not drill deep enough for the stem extension and the associated cement mantle. Do not use any other Persona Stem Extension Drills with the 14 mm x +30 mm tapered stem implant. Confirm that the drill used has the 14 mm x +30 mm labeling before drilling (Figure 5).

ⓘ **Note:** Do not use the NexGen Drill Guide and/or NexGen Sizing Plates with the Persona Stem Extension Drill.

Use the cemented tibial drill and drill until the center of the size-specific engraved line on the cemented tibial drill is in line with the top of the cemented tibial drill guide (Figure 5). After drilling is complete, remove the cemented tibial drill guide.

ⓘ **Technique Tip:** Insert the cemented tibial drill 14 mm x +30 mm into cemented tibial drill guide prior to starting the drill. By hand, hold the cemented tibial drill guide flush against the cemented tibial sizing plate while drilling.



Figure 6

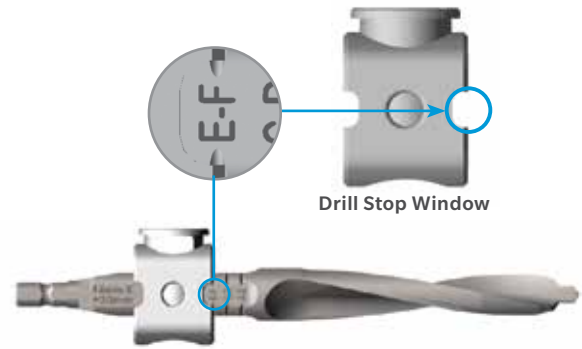

Figure 7

Sizing and Drilling of the Tibia (Alternative Technique)

If desired, the cemented tibial drill stop collar may be used to aid in drilling to the correct depth. Depress the button on the cemented tibial drill stop collar and slide the cemented tibial drill stop collar to the desired size-specific position on the cemented tibial drill 14 mm x +30 mm (Figure 6).

Confirm that the correct size is displayed in the cemented tibial drill stop collar window (Figure 7) and that the cemented tibial drill stop collar is locked on the 14 mm x +30 mm cemented tibial drill.

ⓘ Technique Tip: Verify that the cemented tibial drill stop collar is locked on the 14 mm x +30 mm cemented tibial drill by attempting to slide the cemented tibial drill stop collar on the cemented tibial drill by hand. The cemented tibial drill stop collar will make an audible click when it locks on the drill.

Persona Tibial Sizing Plate Handle
42-5399-017-00

Persona Cemented Tibial Sizing Plate Size F Right
42-5399-075-02

Persona 14 mm x +30 mm, 15.7 mm Diameter Tibial Drill
42-5399-018-14

Persona Cemented Tibial Drill Guide - 15.7 mm
42-5399-020-00

Persona Cemented Tibial Drill Stop Collar, 15.7 mm
42-5399-019-00



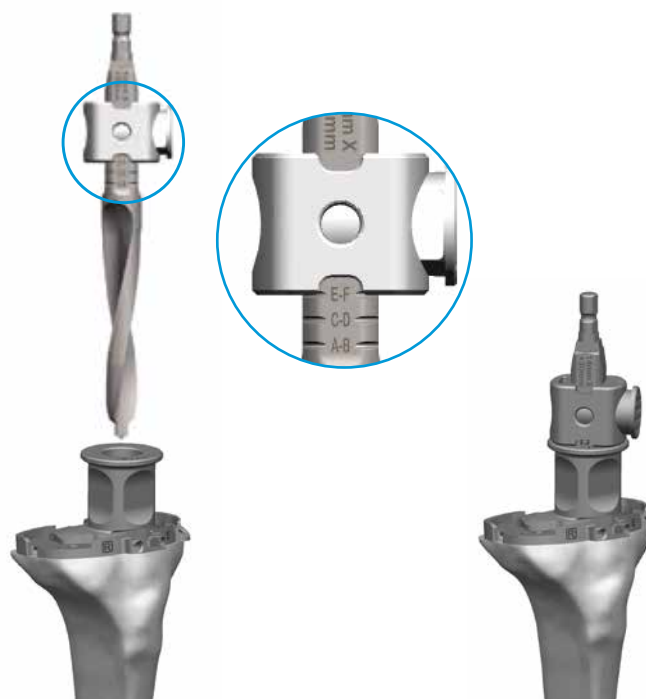

Figure 8

Sizing and Drilling of the Tibia (Alternative Technique) (cont.)

☰ **Technique Tip:** Insert cemented tibial drill 14 mm x +30 mm into cemented tibial drill guide prior to drilling.

After positioning the cemented tibial drill stop collar in the proper position, drill through the cemented tibial drill guide until the cemented tibial drill stop collar contacts the cemented tibial drill guide (Figure 8). After drilling is complete, remove the cemented tibial drill and cemented tibial drill guide from the cemented tibial sizing plate.

☰ **Technique Tip:** When drilling, if you feel that excessive contact with the bone cortex is occurring, stop drilling and remove the drill, guide, and sizing plate. Utilize the provisional stem extension construct to check whether the fit in the bone is proper to be able to use the 14 mm x +30 mm stem extension or not. Downsize the tibia if a shorter tibial keel is needed.

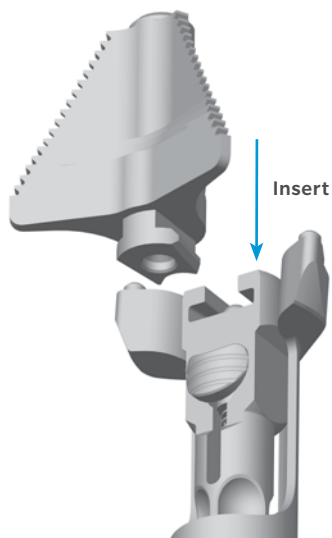

Figure 9

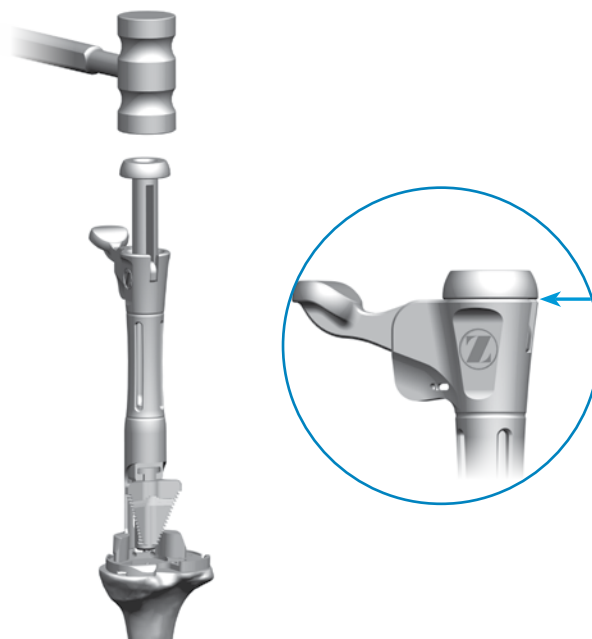

Figure 10

Broaching the Tibia

Insert the correct-sized cemented tibial broach into the cemented tibial broach inserter/extractor handle, (Figure 9). Retract the impaction head until it locks in the fully retracted position, which will facilitate placement on the cemented tibial sizing plate. After seating the cemented tibial broach inserter/extractor handle on the cemented tibial sizing plate, tap the impaction head once to seat the cemented tibial broach.

Impact the cemented tibial broach inserter/extractor handle assembly with care to prevent fracture of the tibia (Figure 10). Impact until the impaction head bottoms out on the cemented tibial broach inserter/extractor handle stop (Figure 10 inset).

Persona Cemented
Tibial Broach Size EF
42-5399-022-05

Persona Cemented
Tibial Broach Inserter/
Extractor Handle
42-5399-023-00

Persona Cemented Tibial
Sizing Plate Size F Right
42-5399-075-02



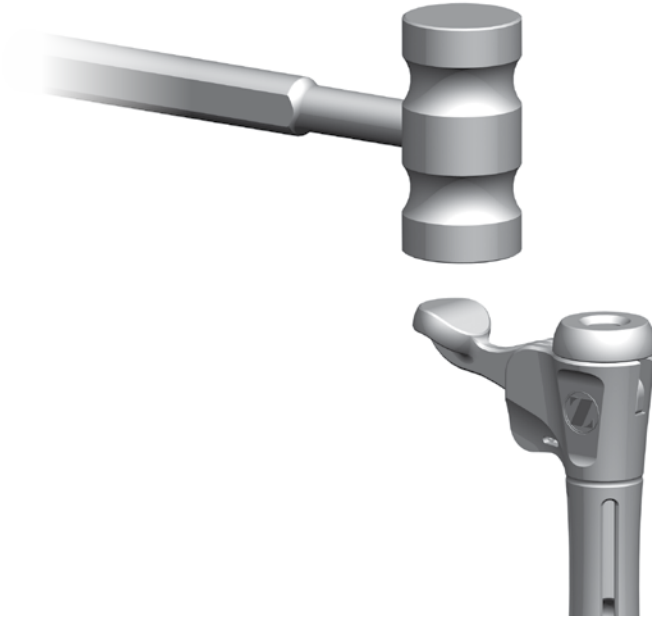

Figure 11

Broaching the Tibia (cont.)

While holding the cemented tibial broach inserter/extractor handle, impact the extraction button to remove the cemented tibial broach from the bone (Figure 11). Avoid dislodging the cemented tibial sizing plate when removing the cemented tibial broach inserter/extractor handle.

☹ **Technique Tip:** Assure that no metallic debris is present on the magnetic feet of the cemented tibial broach inserter/extractor handle as this may inhibit the mating with the cemented tibial sizing plate and may introduce unwanted debris into the surgical site.

☹ **Technique Tip:** Make sure that the cemented tibial broach inserter/extractor handle remains flush against the cemented tibial sizing plate and in full contact with the cemented tibial sizing plate and that the cemented tibial broach inserter/extractor handle does not tip during impaction. The orientation of the cemented tibial broach inserter/extractor handle is important to ensure proper and complete broaching resulting in full seating of the tibial implant on the bone.

☹ **Technique Tip:** DO NOT extract with mallet blows on either the medial or lateral side of the under surface of the impaction head of the cemented tibial broach inserter/extractor handle. DO NOT attempt to extract the cemented tibial broach with a horizontal or angled blow on any side of the cemented tibial broach inserter/extractor handle.



Figure 12

Provisional Assembly and Trialing

Assembling the Tapered Stem Provisional to the Stemmed Tibial Provisional

When assembling the stemmed tibia provisional with the stem provisional, start with the tibia tray facing down on a padded surface then thread the stem onto the female end of the stemmed tibia provisional (Figure 12).

- ⓘ **Note:** Make sure to thread the tapered stem provisional in first before trialing the knee using the CPS TASP lockdown screw.
- ⓘ **Note:** Only hand-tighten the provisional stem.

2.5 mm Male Hex Driver
42-5099-025-00



25 mm x 2.5 mm Female Hex Screw
42-5099-025-25



Persona Stemmed Tibia Provisional
42-5321-075-02



Persona 14 mm x +30 mm Tapered Stem Provisional
42-5571-001-14



Tibial Provisional Extractor
00-5977-017-00



CPS Lock Down Screw, Short
42-5376-001-00



CPS Lock Down Screw, Long
42-5376-001-01





Figure 13

Reference Persona 14 mm x +30 mm Stem Extension compatibility chart below for the appropriate tibia-to-stem compatibility. The stem extension is compatible with all Persona Cemented Stemmed Tibial Plates.

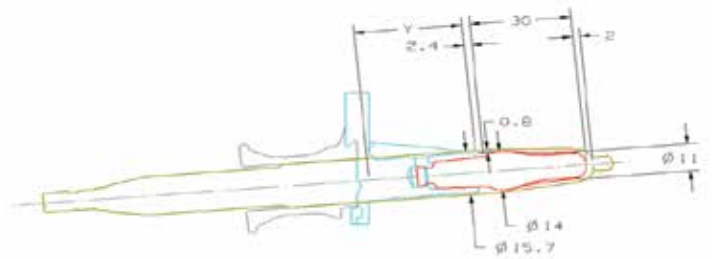

Figure 14
(Dimensions in mm)

Provisional Assembly and Trialing (cont.)

Using the Stemmed Tibial Provisional Construct

When using the stemmed tibial provisional: assemble the stemmed tibial provisional to the tibial provisional extractor and insert in the prepared tibial bone. For additional fixation of the fully seated provisional, insert a 25 mm x 2.5 mm screw (2.5 mm female hex) with the 2.5 mm male hex driver through a screw fixation hole located in the medial and/or lateral compartments of the stemmed tibia provisional (Figure 13).

Note: Do NOT use 48 mm screws for cemented tibial sizing plate fixation. 48 mm screws are not recommended due to potential bone perforation.

Refer to the table below for the depth of the Persona Stem Tibia (Figure 14).

| Tibia Size | Y |
|------------|------|
| A | 23.4 |
| B | 23.4 |
| C | 27.7 |
| D | 27.7 |
| E | 32 |
| F | 32 |
| G | 36 |
| H | 36 |
| J | 40 |

| Tibia Size | Persona Stem Extensions |
|------------|-------------------------|
| A | 14 mm x +30 mm |
| B | |
| C | |
| D | |
| E | |
| F | |
| G | |
| H | |
| J | |



Figure 15

Inserting the Stem into the Implant

Preparing the Tibial Stem Extension

The Persona Tibial Keel length ranges from 23.4 mm to 40 mm (Figure 14). The Persona 14 mm x +30 mm Stem adds 32.4 mm to the length of the tibial keel nominally when assembled (Figure 14).

For the tibial stem extension, first position the tibia implant with the face plate down on a padded surface (Figure 15).

The locking mechanism between the tibia implant and the stem extension implant is a combination of a taper and a set screw. Check to ensure that the set screw has not migrated or fallen into the tibial stem base or package prior to inserting the stem extension into the stem base of the tibia. Back out the locking set screw from the tibia with the hex driver to remove the plastic plug within the taper. Once it is confirmed that the screw is not going to interfere with the stem extension, insert the stem extension taper into the tibia taper until fully seated. When a "snug" fit is achieved, wrap the tibial component in a cloth and place it on a surgical cart.

Persona Stemmed
Tibia Provisional
42-5321-075-02



Persona 14 mm x +30 mm
Tapered Stem Provisional
42-5571-001-14



Femoral Set
Screw Hex Driver
00-5987-071-00





Figure 16



Figure 17

Inserting the Stem into the Implant (cont.)

Preparing the Tibial Stem Extension (cont.)

While protecting the stem extension, strike it solidly multiple times until it is fully seated with a two-pound mallet.

- ⓘ **Note:** Once the stem extension is impacted into the tibia, tighten the set screw and torque until hand tight with the femoral set screw hex driver (Figure 16).
- ⓘ **Note:** Verify the stem is fully seated after impacting and torquing the set screw (Figure 17).
- ⓘ **Note:** The femoral set screw hex driver is designed to limit the amount of torque which can be applied to the screw and is designed to break off if over-torqued. Torque by hand only.

- ⓘ **Note:** The Persona 14 mm x +30 mm Stem Extension is compatible with the Persona Cemented Stemmed Tibial Plates and is not to be used with the NexGen or Natural-Knee II Tibial Plates. For cemented use only.
- ⓘ **Technique Tip:** Do not implant the Persona Cemented Stemmed Tibia without the set screw. It is recommended that a spare set screw be brought to each surgery. The part number of the set screw is 00-5988-090-00.

Implant Components

⊖ **Technique Tip:** Prior to cementing implants remove provisionals and use pulse lavage to remove unwanted debris from the resected bone surfaces and the joint space.

In this step, the final components are implanted, and the tibial bearing is secured to the implanted tibial baseplate. When using cemented components, it is recommended to use two batches of cement.

After the implants have been chosen, make a final check to ensure that all components are compatible. If the resected surfaces of the tibia and/or femur are sclerotic, drill multiple holes with a small drill (2.0 mm–3.2 mm) to improve cement intrusion. Mix cement following the manufacturer's guidelines for cement prep including but not limited to mix, work, and set time.

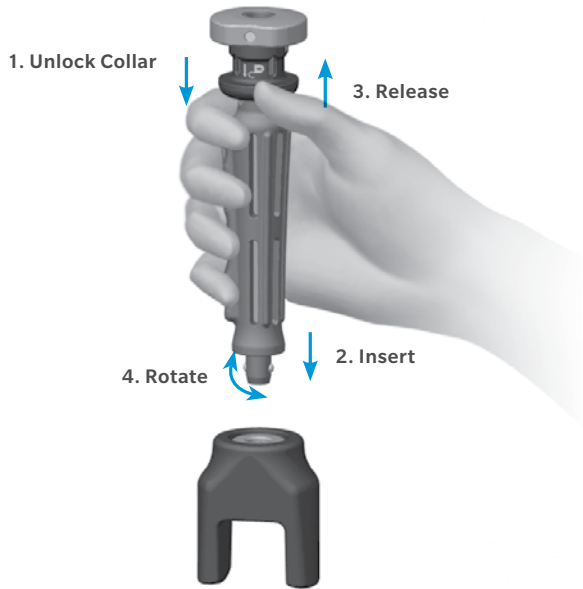

Figure 18



Figure 19

Implant Components (cont.)

Tibial Plate

Sublux the tibia anteriorly to allow adequate clearance to insert the tibial implant into the prepared bone. Do not apply substances other than bone cement to the tibial implant (i.e. do not dip implant into antibiotics or other substances). Keep the implant clean and free of debris prior to cementing. Place a layer of cement on the underside of the tibial baseplate, around the keel, on the resected tibial surface, and in the tibial IM canal. Assemble the quick connect handle to the tibial impactor head (Figure 18). Unlock collar and hold, insert handle into impactor head, release collar, and rotate handle until “click” is heard. Position the tibial plate onto the tibia and use the tibial impactor to impact it until fully seated (Figure 19).

Thoroughly remove any excess cement in a consistent manner. Allow the cement to fully cure before performing a trial ROM or inserting the bearing per the manufacturer's recommended guidelines.

Quick Connect Handle
00-5901-034-00

Tibial Impactor Head
00-5901-033-00

Persona Cemented
Stemmed Tibial Plate
Sizes F Right
42-5320-075-02



All content herein is protected by copyright, trademarks and other intellectual property rights, as applicable, owned by or licensed to Zimmer Biomet or its affiliates unless otherwise indicated, and must not be redistributed, duplicated or disclosed, in whole or in part, without the express written consent of Zimmer Biomet.

This material is intended for health care professionals. Distribution to any other recipient is prohibited.

For product information, including indications, contraindications, warnings, precautions, potential adverse effects and patient counseling information, see the package insert and zimmerbiomet.com.

Zimmer Biomet does not practice medicine. This technique was developed in conjunction with a health care professional. This document is intended for surgeons and is not intended for laypersons. Each surgeon should exercise his or her own independent judgment in the diagnosis and treatment of an individual patient, and this information does not purport to replace the comprehensive training surgeons have received. As with all surgical procedures, the technique used in each case will depend on the surgeon's medical judgment as the best treatment for each patient. Results will vary based on health, weight, activity and other variables. Not all patients are candidates for this product and/or procedure.

Caution: Federal (USA) law restricts this device to sale by or on the order of a surgeon. Rx only.

© 2018 Zimmer Biomet



EU Authorized Representative

Zimmer U.K. Ltd.
9 Lancaster Place
South Marston Park
Swindon, SN3 4FP, UK



ZIMMER BIOMET

Your progress. Our promise.®



Legal Manufacturer

Zimmer, Inc
1800 West Center Street
Warsaw, IN 46581-0708
USA

zimmerbiomet.com

CE 0086

CE mark on a surgical technique is not valid unless there is a CE mark on the product label.