

Comprehensive[®] Fracture System

Surgical Technique





Figure 1



Figure 2

Preoperative Planning

Evaluate X-rays of both the fractured shoulder and the contralateral shoulder. Ensure both X-rays are at the same degree of external rotation. Determine amount of comminution and proximal bone loss on X-ray and/or CT scans. Find a bony landmark along the fracture line that can be used as a reference and draw a line on the X-ray at that exact point. In many instances, the medial calcar can be used (Figure 1).

Flip the fracture X-ray and align it over the chosen bony landmark on the contralateral shoulder X-ray.

The Comprehensive Fracture System templates are then placed over the contralateral shoulder and the proper stem size is selected.

Using the selected stem size, note the previously drawn line and the hashmark to which it corresponds. For example, if the line made on the medial calcar aligns with the line between the 4 and 5 hashmark, the fracture stem will be inserted to that depth. The height determined here will be used throughout the surgical technique.

The humeral head size can be estimated by overlaying the head templates over the contralateral humeral head. A second check in proper placement of the stem is performed by overlaying the head and stem together at the appropriate position within the humeral canal.

Patient Positioning

Place the patient in a modified beach chair position at 30–45 degrees after general or regional anesthetic has been induced and a prophylactic dose of a broad-spectrum antibiotic has been administered. Lateralize the patient on the edge of the table so that the arm can be extended off the side (Figure 2).

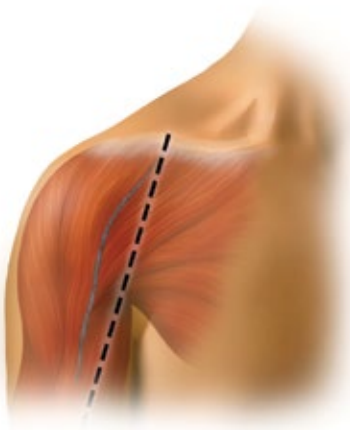

Figure 3



Figure 4



Figure 5

Approach

Mark the skin incision for an extended deltopectoral approach (Figure 3). Begin the incision over the clavicle, directly superior to the coracoid process, and pass over the coracoid, sweeping laterally and distally to end at the insertion of the deltoid onto the humerus (Figure 4). This approach allows for detachment of part of the distal deltoid insertion if further mobilization of the deltoid is required.

As dissection proceeds, identify the cephalic vein, a landmark of the deltopectoral interval. This vein is usually identified by its surrounding fatty tissue (Figure 5).



Figure 6



Figure 7

Dissection of Soft Tissue

The cephalic vein is usually firmly embedded in the deltoid, with many feeders from the deltoid to the cephalic vein. The vein may either be sacrificed or reflected. The distal deltoid may be partially released from its humeral insertion, but the proximal origin should not be violated.

In fracture cases, it is especially important to identify and protect the musculocutaneous and axillary nerves. Palpate the musculocutaneous nerve as it comes from the plexus into the posteromedial aspect of the conjoined tendon (Figure 6). With further dissection, the medial branches of the cephalic vein that cross the incision are identified, divided and cauterized.

Next, divide the claviclepectoral fascia and retract the conjoined tendon, avoiding traction on the musculocutaneous nerve, which lies distal to the coracoid process (Figure 7). The nerve usually penetrates the muscle one to two inches inferior to the tip of the coracoid process, but in some instances the nerve has a higher penetration into the conjoined muscle tendon unit. It is important to remember the location of this nerve when retracting the conjoined tendon. A partial tenotomy may be considered to reduce the tension during exposure.

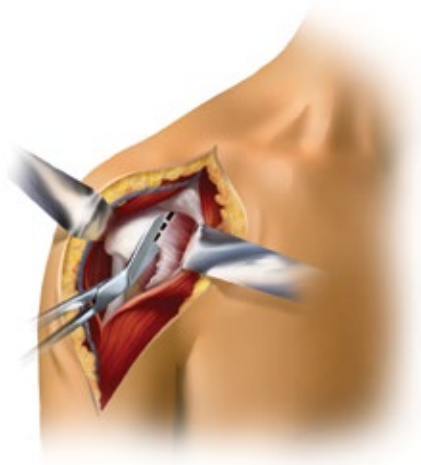

Figure 8

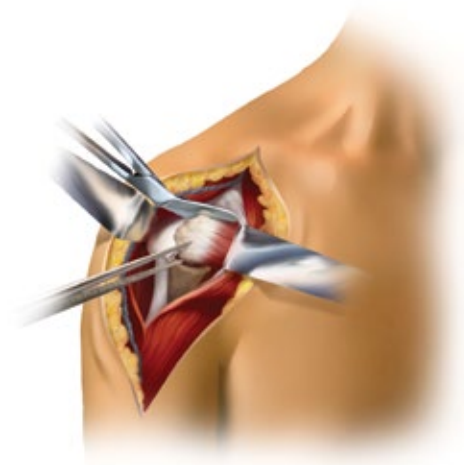

Figure 9

Identifying the Lesser and Greater Tuberosity Fragments Using the Biceps Tendon

The biceps tendon and bicipital groove afford the most useful anatomic landmark for identification of the fractured tuberosity fragments. Place a pair of scissors into the sheath of the biceps tendon and use them to divide the transverse ligament (Figure 8).

Continuing proximally with the scissors, open the interval between the subscapularis and the supraspinatus tendons all the way up to the insertion of the biceps tendon into the supraglenoid tubercle. Even if the biceps tendon is ruptured, place the scissors into the bicipital groove and use them to open the interval between the subscapularis and the supraspinatus tendon. Free up the lesser tuberosity from the underlying humeral head and soft tissue (Figure 9).

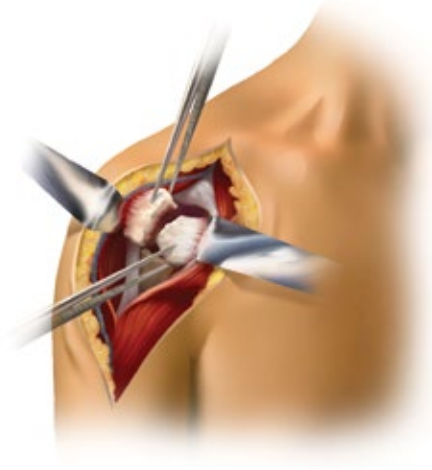

Figure 10

Identifying the Lesser and Greater Tuberosity Fragments Using the Biceps Tendon (cont.)

The fracture may need to be completed with an osteotome or elevator. Protect the axillary nerve during mobilization of both the lesser and greater tuberosities and the attached rotator cuff muscle tendon unit. Once the tuberosities have been identified, place three nonabsorbable #5 sutures through the attached tendon. The greater and lesser tuberosity fragments must be sufficiently freed so they can be easily repaired around the prosthesis and to each other at the time of closure (Figure 10). By retracting the greater and lesser tuberosities, improved access is provided to the glenohumeral joint.

Humeral Head Retrieval

Identify and remove the articular segment of the humeral head using the tuberosity clamps. If performing a total shoulder arthroplasty, size the head with calipers or by direct comparison to the available head trials.

Assess the proximal humerus for shortening due to proximal metaphyseal comminution. This must be considered in placement of the prosthesis. Evaluate the glenoid surface. If it is damaged significantly, or if chronic cartilage loss is present, glenoid replacement may be performed.

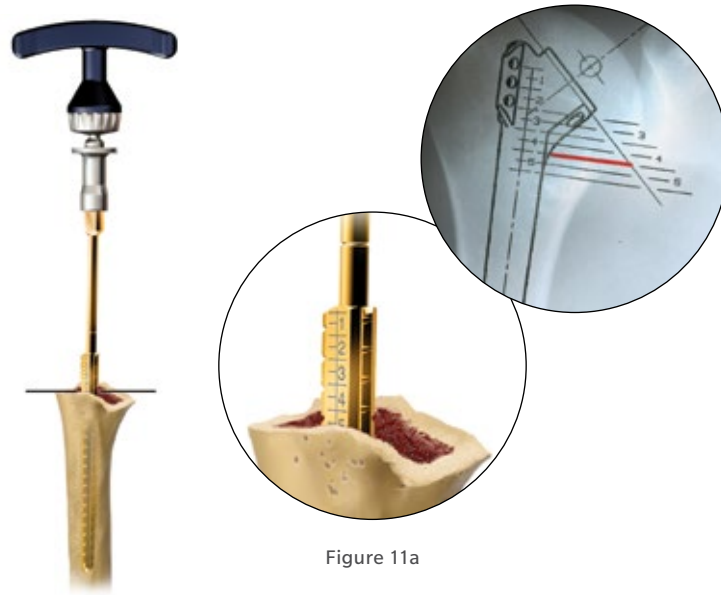

Figure 11

Figure 11a

Humeral Preparation

Step 1 – Ream [Cemented & Press Fit Stem]

Humeral shaft preparation is facilitated by extension, adduction and external rotation of the humerus. If a chronic fixed posterior dislocation with associated humeral head fracture of greater than 50% is being treated, less retroversion will be necessary.

Attach the T-handle to the 4 mm reamer and sequentially ream in 1 mm increments until cortical contact has been achieved, being careful to not overream.

Note: The 4 mm and 5 mm reamers do not have hashmarks for depth. They are designed to open the canal to accept the 6 mm reamer and larger.

Depth of reaming is determined by aligning the appropriate hashmark on the reamer with the predetermined bony landmark of the humerus as determined in preoperative planning, ensuring line to line alignment (Figures 11 and 11a). For example, if the medial calcar was shown preoperatively to line up with the line between the 4 and 5 hashmark, continue reaming to that depth.

Note: If the stem will be press-fit, keep in mind that although reamers size in 1mm increments, the stem is sized in 2 mm sizing increments from 4mm to 14mm. There is the 1.5 mm circumferential PPS® coating on the proximal portion of the stem which will achieve the press fit in the humeral canal. Standard impaction bone grafting may be utilized when between implant sizes to enhance implant stability.

Reaming should allow the shaft to accept the correct size stem in approximately 20–40 degrees of retroversion. The reamer that achieves cortical contact is the basis on which the final implant size is determined.

Note: Once reaming is complete, if the stem will be press fit, please skip steps 2 and 3 and proceed to “Humeral Trial Stem Insertion” (page 10) as the positioning sleeve described in the following steps will not be utilized.

Ratcheting T-handle
406801



Humeral Reamers 4mm
41-406804





Figure 13

Step 2 – Tap [Cemented Stem Only]

Remove the T-handle from the reamer and attach it to the corresponding tap. For example, if the 8 mm reamer was the final reamer used in Step 1, select the 8 mm tap.

If a cement plug is desired, it should be placed down the canal before tapping. It is recommended to use a size just big enough to occlude the flow of cement, yet small enough to avoid any extra pressure on the cortical walls.

Insert the selected tap down the shaft to the predetermined hashmark (Figure 13). A clockwise rotation will feed the tap into the intramedullary canal. A counterclockwise rotation will draw the tap from the canal.

Note: The tap will thread the canal distally an extra 12.7 mm, or one full sleeve’s length, to allow for any necessary height adjustment when trialing.

Caution: Do not attempt to force the bone tap down the humeral canal. If necessary, use a tap that is 1 mm smaller than the last reamer used.

Cement Plug Inserter
407099



Ratcheting T-handle
406801



Comprehensive Positioning
Sleeve Taps



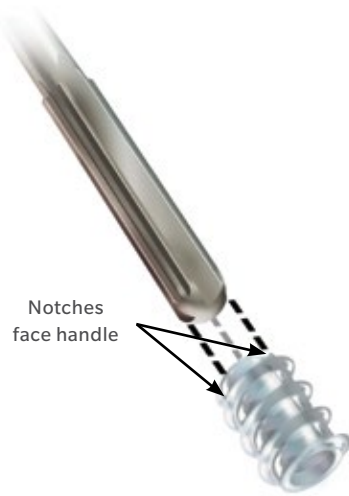

Figure 14



Figure 15

Humeral Preparation (cont.)

Step 3 – Insert Sleeve [Cemented Stem Only]

Choose the sleeve inserter that corresponds with the respective reamer/tap used. For example, if the 8 mm reamer and tap are used, the 8 mm positioning sleeve is selected and inserted (see sizing chart on vpage 22). The implant positioning sleeve is placed onto the inserter with the sleeve notches facing the T-handle (Figure 14).

Insert the sleeve down the shaft with a clockwise motion to the predetermined hashmark (Figure 15). Once the sleeve is positioned at the appropriate depth, pull the sleeve inserter out of the humerus.

ⓘ **Note:** Sleeve adjustments can be made by re-engaging the sleeve and inserter. Use the same clockwise/ counterclockwise rotation as described previously.

Comprehensive Positioning Sleeve Taps



Comprehensive Sleeve Inserters



Ratcheting T-handle
406801



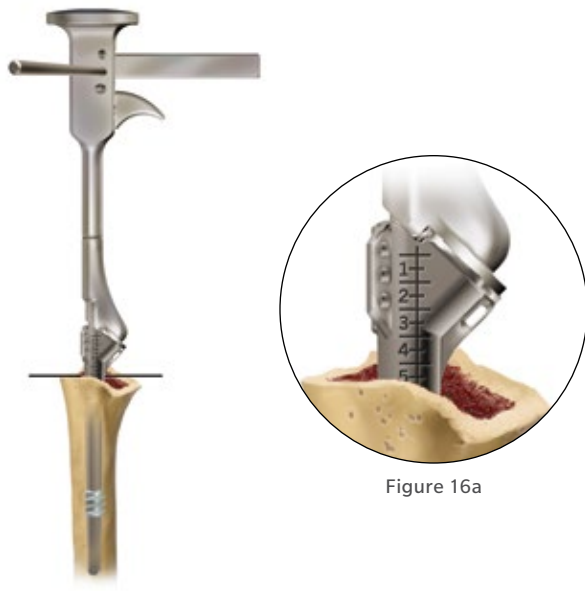

Figure 16

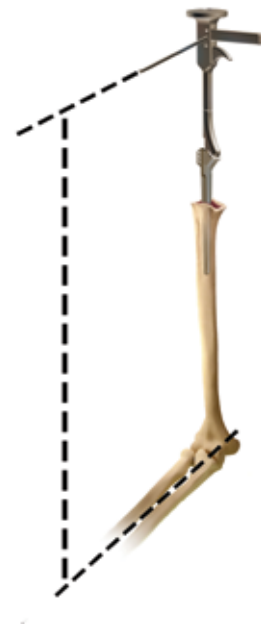

Figure 17

Humeral Trial Stem Insertion

Select the appropriate trial based on humeral canal preparation (see sizing chart on page 22).

For a cemented stem, select a trial stem 2–3 mm smaller than the size of the final reamer used in canal preparation in order to allow for a 2–3 mm cement mantle.

For a press fit stem, select a trial stem equal to the size of the final reamer used, ensuring reaming was conducted to an even size.

Note: The porous coating on the proximal portion of the stem is 1.5 mm circumferentially, which will cause the final implant to fit tighter than the trial stem.

Attach the version rod to the inserter handle and the trial prosthesis to the inserter handle and place in the canal (Figures 16a and 16b).

Check for correct sizing, version and humeral length by ensuring alignment rod is parallel to the long axis of the forearm (Figure 17). This will place the trial in the desired amount of retroversion. The trial stem should be positioned at the exact hashmark used during the reaming process, and the corresponding tapping and sleeve insertion process for a cemented stem.



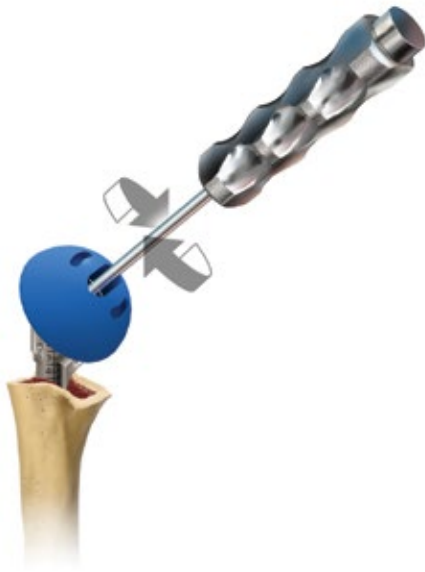

Figure 18



Figure 19

Humeral Trial Stem Insertion (cont.)

Hemiarthroplasty or Total Shoulder Arthroplasty

Select the humeral head trial that most closely replicates the original articular segment and assemble to a standard trial taper adaptor. Place on trial stem and tighten the taper adaptor trial in the head trial with a hex driver to the desired offset position (Figure 18). Reduce the joint and perform a trial range of motion.

Note: The head trial will still rotate within the broach. The screw only locks in the desired amount of offset.

With the forearm at neutral, or zero degrees rotation, the head should point at the glenoid (Figure 19). Test humeral length intraoperatively by attempting to sublux the humerus inferiorly. Normally, the humeral component should travel only 25 to 50% of the length of the glenoid with inferior traction. If more than that is possible, the prosthesis is seated too low. In this case, the deltoid function will likely be poor due to

inadequate length and tension. If there is no inferior play, the humerus is too high and should be sunk deeper into the shaft or it will be prone to impingement and may place undue stress on the glenoid.

Proper tension can also be evaluated by measuring the distance between the pectoralis tendon insertion to the top of the prosthetic head which should be approximately 5.6 cm. If adjustments are needed, the sleeve can be screwed up or down in the canal to modify the height of the humeral trial.

Remove the Versa-Dial trial assembly from the humeral fracture stem. Keep Versa-Dial trial assembly together for final trialing with implanted stem and move to page 14.





Figure 20

Humeral Trial Stem Insertion (cont.)

Reverse Shoulder Arthroplasty

To trial for a reverse shoulder arthroplasty, select the appropriately sized one-piece trial humeral tray/bearing. Noting the “SUPERIOR” and “INFERIOR” markings on the humeral tray, place the trial humeral tray/bearing into the trial stem (Figure 20) and perform a trial reduction to assess range of motion and implant size selection. The trial reduction should show very limited distraction (1 mm or less).

- Note:** In cases of extreme instability, +3 mm retentive humeral bearings are available. Retentive bearings capture more of the glenosphere and have polyethylene walls which are 2–3 mm higher than standard +3 mm bearings, but do not add any additional joint space. Depending on variations in instrument tray layouts, the retentive bearings may be found in the revision instrument tray.

36 mm Humeral Tray/Bearing
Provisionals



41 mm Humeral Tray/Bearing
Provisionals



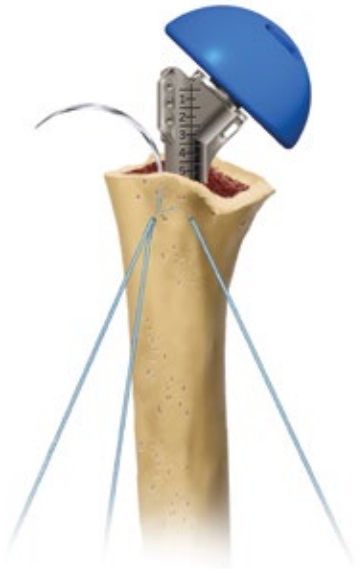

Figure 21

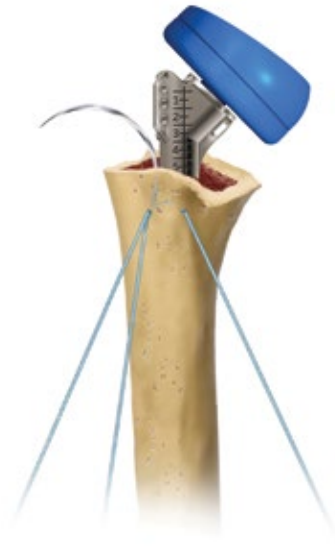

Figure 22

Humeral Trial Stem Insertion (cont.)

Whether trialing for a humeral head or humeral tray/bearing, radiography or fluoroscopy may be used at this time to determine if implant size and positioning are correct.

The anterolateral fin is immediately lateral to the bicipital groove. Therefore, the lateral edge of the bicipital groove may be directly lined up with the leading fin. Before implanting the appropriate stem, drill two holes in the humeral shaft, medial and lateral to the bicipital groove.

Pass one #5 nonabsorbable suture front to back through these holes to be used later as a figure-of-eight tension band. Pass a second #5 nonabsorbable suture through the lateral hole for longitudinal fixation of the greater tuberosity (Figure 21 and Figure 22). After final check of the stem fit with the trial implant, prepare and dry the canal.



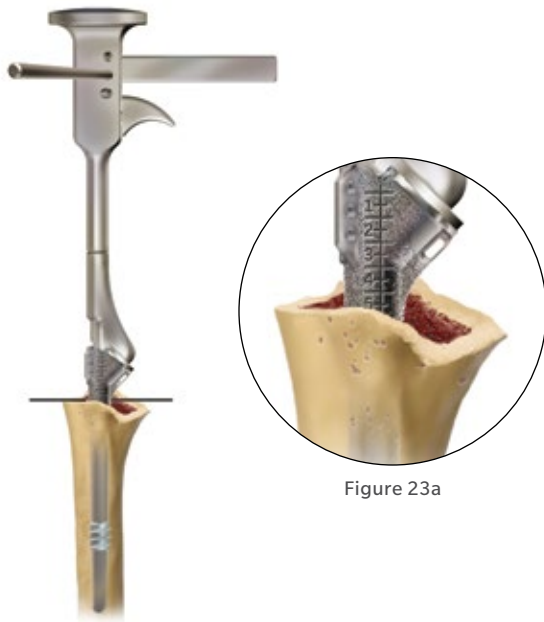

Figure 23

Figure 23a



Figure 24

Implanting the Humeral Stem

Cemented Stem

The internal positioning sleeve is designed to be used with cement. Once in the desired position, cement is introduced into the canal and the stem is placed at the pre-determined hashmark with the desired amount of retroversion using the fracture stem inserter (Figure 23). There will be less retroversion in cases of fixed posterior dislocation.

Note: The humeral shaft does not need to be pressurized during cement insertion with a distal plugging device. Humeral shaft bone stock may be extremely thin and pressurization can result in either fractures of the proximal shaft during cementing or cement extruding from the humeral shaft and endangering the radial nerve. If a cement plug was inserted prior to tapping, ensure the size is just big enough to occlude the flow of cement, yet small enough to avoid any extra pressure on the cortical walls.

Press Fit Stem

Assemble the selected fracture stem onto the fracture stem inserter. Insert the stem into the humeral canal, impacting if necessary, and using the version rod to ensure alignment (Figure 24).

Comprehensive Fracture Stem
(Macrobond)



Comprehensive Fracture Stem
(PPS)



Fracture Stem Inserter
31-406901



Mallet

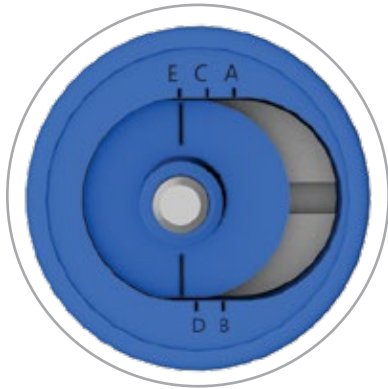

Figure 25



Figure 26

Humeral Head - Trialing and Insertion

Once the stem has been implanted for a hemiarthroplasty or total shoulder arthroplasty, place the selected head trial back onto the implanted stem and reduce the joint. With tension maintained in the tuberosities, assess anterior stability, posterior stability and range of motion.

Attempt to recreate a 50% translation relative to the glenoid anteriorly, posteriorly and inferiorly. In addition, a full range of forward flexion and abduction should be possible without tuberosity impingement. Continue to trial until all criteria are fulfilled.

Remove the trial and determine the amount of offset needed by referencing the indications on the underside of the trial head and trial adaptor (Figure 25), keeping in mind that the offset chosen may be between letters.

Place the Versa-Dial head into the impactor tray. Ensuring the components are clean and dry, insert the Versa-Dial taper adaptor into the head (Figure 26).

Rotate the taper adaptor until the trial offset is replicated. For example, if trialing indicated halfway between the B and C hashmarks, the implant taper adaptor is aligned so its hashmark is halfway between the B and C on the head.

Versa-Dial Humeral Head Trial Head



Comprehensive Standard Trial Taper Adaptors
407280



Comprehensive Standard Trial Taper Adaptors
407281





Figure 27



Figure 28

Humeral Head - Trialing and Insertion (cont.)

Engage the Morse taper with two firm strikes, using the taper impactor tool and mallet (Figure 27). The taper/ head assembly is now securely fastened.

Clean and dry the reverse Morse taper. Gently place the Versa-Dial head onto the stem and rotate to achieve replicates the original articular segment. This coverage should replicate the offset direction that was used while performing the trial reduction.

Impact the head onto the stem to complete humeral head implantation by using at least two blows with an appropriately sized surgical mallet and the head impactor tool (Figure 28).

Comprehensive Standard
Trial Taper Adapters
407280



Comprehensive
Standard Trial Taper Adapters
407281



Fracture Stem Inserter
407297



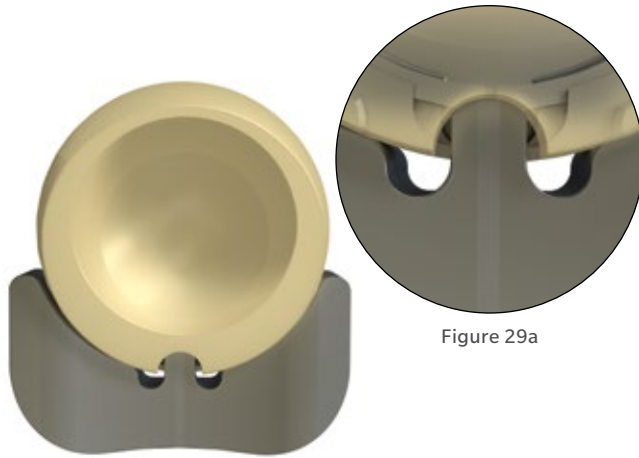

Figure 29

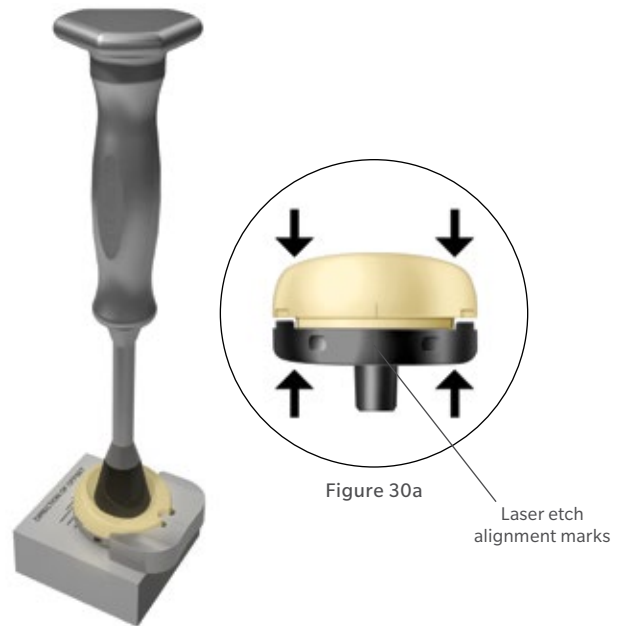

Figure 30

Humeral Tray – Trialing and Insertion

For a reverse shoulder arthroplasty, reduce the joint with the humeral tray and bearing trial, and attempt to recreate the range of motion seen with the trial stem and check that the trial reduction shows very limited distraction (1 mm or less).

To assemble the humeral tray and bearing implants, utilize the bearing assembly tool to first spread the RingLoc locking mechanism to the open position by fully seating the bearing assembly tool on the humeral tray. An audible “click” will be heard when the bearing assembly tool is properly engaged (Figure 29).

Next, place the engaged bearing assembly tool and humeral tray on the glenosphere offset orientation block. Position the definitive humeral bearing in the definitive humeral tray, ensuring that the laser etching on the bearing aligns with the laser etching on the humeral tray. Using the humeral bearing/tray impactor tool, apply downward pressure to the bearing and remove the bearing assembly tool continuing to apply downward pressure on the bearing. With two firm strikes of the humeral tray/ bearing impactor, impact the humeral bearing into the humeral tray (Figure 30). Following inspection, ensure the humeral bearing is fully seated within the humeral tray.

Offset orientation block
405887



Humeral Bearing Assembly Tool
110017268



Humeral Bearing/Tray Impactor
405835





Figure 31

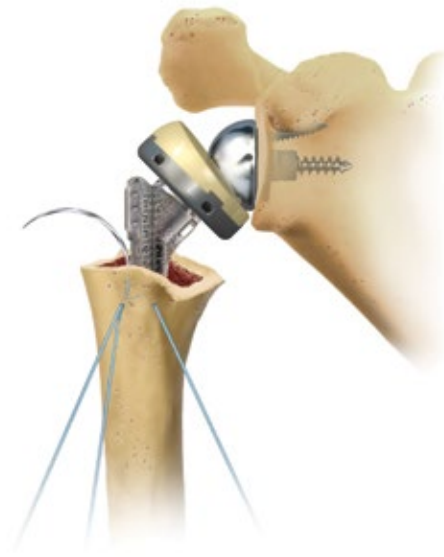

Figure 32

Humeral Tray – Trialing and Insertion (cont.)

Remove the humeral tray/bearing trial and adequately clean and dry the stem's reverse Morse taper. The humeral tray is marked "SUPERIOR" to aid in positioning the tray/bearing with respect to the stem. When inserted correctly, the thicker portion of the polyethylene bearing should be inferior.

With two firm strikes of the humeral tray/ bearing impactor, impact the assembled definitive humeral tray/bearing into the Comprehensive Fracture stem (Figure 31).

Reduce the joint with the aid of the shoe horn and assess the final range of motion. The final reduction (Figure 32) should show very limited distraction (1 mm or less). Impingement should not be present in either adduction or abduction.

Humeral Bearing/Tray Impactor 405835 Shoehorn 405901



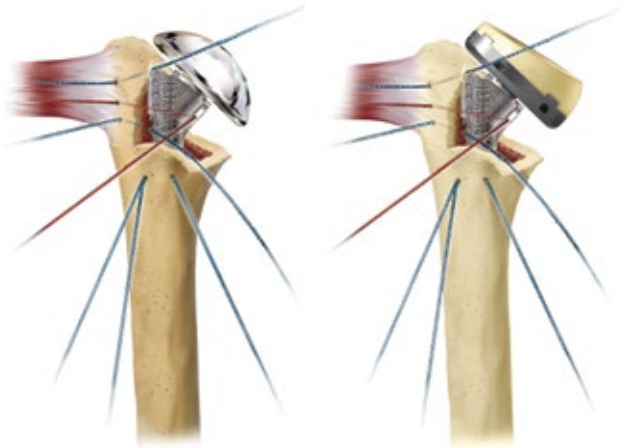

Figure 33

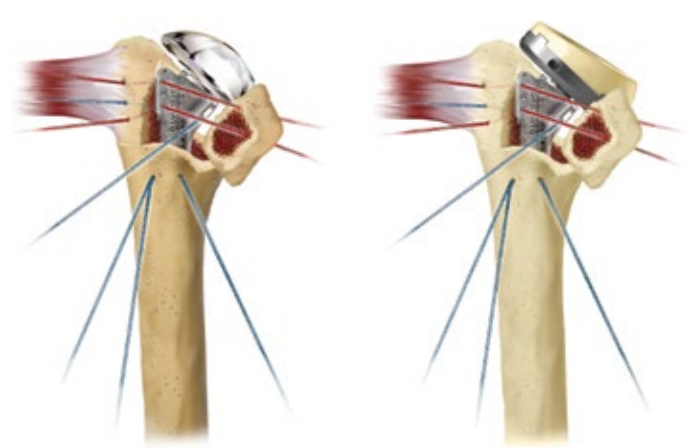

Figure 34

Tuberosity Reattachment

This is the most critical part of the procedure. There are many acceptable variations. The procedure is similar in both hemiarthroplasty and reverse shoulder arthroplasty procedures and involves longitudinal and transverse fixation of the tuberosities to the humeral shaft and themselves around and/or through the implant with the goal to securely fix the greater and lesser tuberosities to the shaft and to each other. Tuberosity clamps can be used to secure tuberosities during reconstruction.

Place three #5 nonabsorbable sutures through the bone tendon interface of the greater tuberosity. Place the middle greater tuberosity suture through the suture hole on the medial neck of the prosthesis (Figure 21).

Next, place the superior and inferior greater tuberosity sutures through the superior and inferior holes in the prosthesis fin. Continue with these sutures through the bone tendon interface of the lesser tuberosity at corresponding levels (Figure 22).

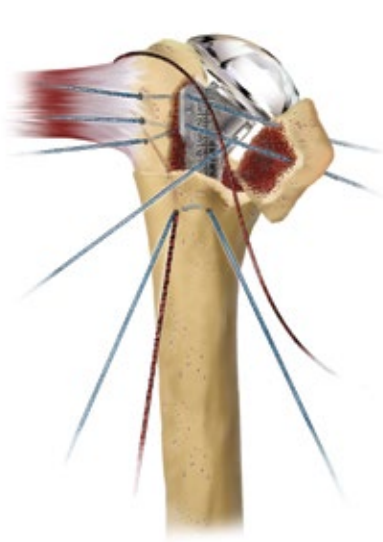

Figure 35

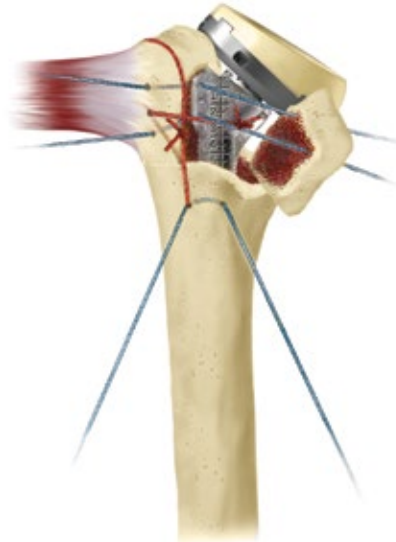

Figure 36

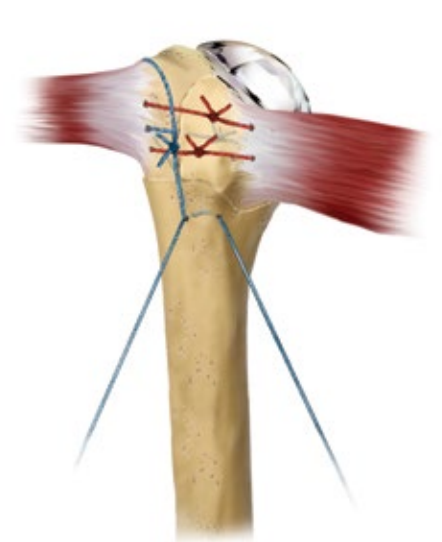

Figure 37

Pass the longitudinal suture, previously placed through the lateral hole in the humeral shaft, inside out through the superior portion of the supraspinatus tendon (if still attached), above the greater tuberosity. Continue with this suture underneath the greater tuberosity sutures (Figure 35).

Tie these sutures in the appropriate order to first secure the greater tuberosity to the humeral shaft and to the prosthesis (Figure 36) and then to secure the lesser tuberosity to the humeral shaft and to the greater tuberosity (Figure 37).

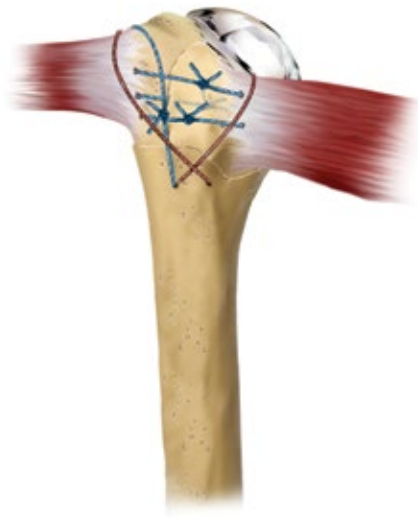

Figure 38

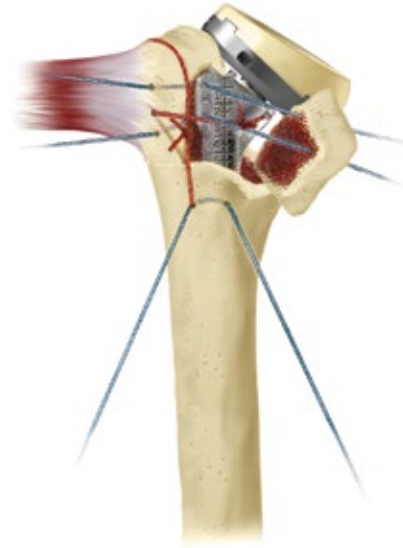

Figure 39

Tuberosity Reattachment (cont.)

Place the figure-of-eight suture that was placed prior to stem insertion from back to front through the rotator cuff and close above the tuberosities, fixing the tuberosities to the humeral shaft (Figure 26). Insert bone graft from the humeral head below the tuberosities for improved healing. The tuberosities should be positioned a few millimeters below the top of the humeral head component. Improper positioning will cause abnormal tensioning on the rotator cuff (if any remaining) and could lead to impingement.

Place the shoulder through a range of motion, noting stability of the tuberosities. This will allow guidance for the postoperative rehabilitation program.

Closure

Close the wound over a wound drain system. Place the arm in a sling and swathe. Begin physical therapy on the first postoperative day.

Comprehensive Fracture System Sizing Chart

Cemented Stem (utilizing the fracture sleeve)

Reamer	Bone Tap	Positioning Sleeve	Sleeve Inserter	Fracture Stem
6 mm	6 mm	6 mm	6 mm or 7 mm	4 mm
7 mm	7 mm	7 mm		
8 mm	8 mm	8 mm	8 mm or 9 mm	6 mm
9 mm	9 mm	9 mm		
10 mm	10 mm	10 mm	10 mm or 11 mm	8 mm
11 mm	11 mm	11 mm		
12 mm	12 mm	12 mm	12 mm or 13 mm	10 mm
13 mm	13 mm	13 mm		
14 mm	14 mm	14 mm	14 mm or 15 mm	12 mm
15 mm	15 mm	15 mm		
16 mm	16 mm	16 mm	16 mm or 17 mm	14 mm
17 mm	17 mm	17 mm		

Press Fit Stem

Reamer	Trial	Fracture Stem
6 mm	6 mm	6 mm
8 mm	8 mm	8 mm
10 mm	10 mm	10 mm
12 mm	12 mm	12 mm
14 mm	14 mm	14 mm

EAS™/Stem Size Combinations

		EAS Head Size								
		40 x 15	40 x 20	44 x 17	44 x 22	44 x 27	48 x 19	48 x 24	54 x 22	54 x 24
Stem Size	4 mm	Yes	Yes	Yes	Yes	Yes	Yes	Yes	Yes	Yes
	6 mm	Yes	Yes	Yes	Yes	Yes	Yes	Yes	Yes	Yes
	8 mm	No	No	No	No	No	Yes	Yes	Yes	Yes
	10 mm	No	No	No	No	No	Yes	Yes	Yes	Yes
	12 mm	No	No	No	No	No	No	No	Yes	Yes
	14 mm	No	No	No	No	No	No	No	Yes	Yes

This material is intended for healthcare professionals and the Zimmer Biomet sales force. Distribution to any other recipient is prohibited. For indications, contraindications, warnings, precautions, potential adverse effects and patient counseling information, see the package insert or contact your local representative; visit www.zimmerbiomet.com for additional product information. All content herein is protected by copyright, trademarks and other intellectual property rights, as applicable, owned by or licensed to Zimmer Biomet or its affiliates unless otherwise indicated, and must not be redistributed, duplicated or disclosed, in whole or in part, without the express written consent of Zimmer Biomet.

For indications, contraindications, warnings, precautions, potential adverse effects and patient counseling information, see the package insert or contact your local representative; visit www.zimmerbiomet.com for additional product information. Check for country product clearances and reference product specific instructions for use. Zimmer Biomet does not practice medicine. This technique was developed in conjunction with health care professional. This document is intended for surgeons and is not intended for laypersons. Each surgeon should exercise his or her own independent judgment in the diagnosis and treatment of an individual patient, and this information does not purport to replace the comprehensive training surgeons have received. As with all surgical procedures, the technique used in each case will depend on the surgeon's medical judgment as the best treatment for each patient. Results will vary based on health, weight, activity and other variables. Not all patients are candidates for this product and/or procedure. Caution: Federal (USA) law restricts this device to sale by or on the order of a surgeon. Rx only.

©2020, 2021 Zimmer Biomet



1426.2-GLBL-en-Issue Date 2021-12-21



Legal Manufacturer
Biomet Orthopedics
P.O. Box 587
56 E. Bell Drive
Warsaw, Indiana 46581-0587
USA

www.zimmerbiomet.com



CE mark on a surgical technique is not valid unless there is a CE mark on the product label.