

ROSA[®] Knee

with
Optimize[™]

User Manual & Surgical Technique

V1.5



Table of Contents

1. General Information	1
1.1 Conventions.....	1
1.2 ROSA Knee System Description	1
1.3 Contact.....	2
1.4 Training	2
1.5 Intended Use	2
1.6 Indications for Use	2
1.7 Contraindications	3
1.8 Complications.....	3
1.9 Restrictions for Use.....	3
1.10 Patents.....	3
2. About This Manual	4
2.1 Safety	4
2.1.1 Warnings, Cautions and Remarks	4
3. Description	10
3.1 Overview	10
3.2 Operating Principle	11
3.2.1 Case Information	11
3.2.2 Pre-operative Planning	11
3.2.3 OR Setup.....	11
3.2.4 Robotic Unit Registration.....	12
3.2.5 Bony Landmarks & Navigation.....	13
3.2.6 Planning.....	13
3.2.7 Surgery	13
3.3 System Description.....	13
3.3.1 Robotic Unit.....	13
3.3.1.1 Robotic Arm.....	15
3.3.1.2 Touchscreen	16
3.3.1.3 Immobilization System	16
3.3.1.4 Vigilance Device (Foot Pedal).....	16
3.3.2 Optical Unit.....	17
3.3.3 Instrumentation	18
3.3.3.1 ROSA Arm Instrument Interface.....	20
3.3.3.2 ROSA Arm Reference Frame	20
3.3.3.3 ROSA Base Reference Frame	20
3.3.3.4 ROSA TKA Cut Guide	20
3.3.3.5 ROSA Registration Pointer	21
3.3.3.6 Universal Validation Tool Body	21
3.3.3.7 Distal & Posterior Condyles Digitizer.....	21
3.3.3.8 ROSA Knee Condyle Digitizer Small/Medium/Large .	21
3.3.3.9 ROSA Knee Tibia Validation Tool	22
3.3.3.10 Bone References	22
3.3.3.10.1 Femoral Reference Frame	22
3.3.3.10.2 Tibia References	24

3.4 Instrumentation Assembly	27
3.4.1 ROSA Arm Instrument Interface on the Robotic Arm	27
3.4.2 ROSA Arm Reference Frame on the Robotic Arm	28
3.4.3 ROSA Base Reference Frame on the Robotic Unit	28
3.4.4 ROSA TKA Cut Guide on the Robotic Arm	28
3.4.5 Universal Validation Tool Body and ROSA Knee Tibia Validation Tool (or Distal & Posterior Condyles Digitizer)	29
3.4.6 Universal Validation Tool Body and Condyle Digitizers (ROSA Knee Condyle Digitizer/Distal & Posterior Condyles Digitizer)	29
3.5 Disposables	29
3.5.1 Reflective Trackers (NavitrackER®) Installation	29
3.5.2 Pins	31
3.5.3 ROSA Checkpoint Screws	31
3.5.4 Drapes	31
4. Installation	32
4.1 Warnings and Cautions About Robotic Unit Installation	32
4.2 Device Start Up	33
4.3 Camera Errors	33
4.3.1 Camera Temperature is Too Low/High	33
4.4 Emergency Procedure	34
4.5 Reverting to Standard Instrumentation	34
4.6 Case Management Application	35
4.6.1 Case Management Application-Interface Overview	35
4.6.2 Starting a Case	35
5. Intra-operative Guide/Surgery	36
5.1 Welcome Screen	36
5.2 ROSA Knee Application-User Interface Overview	36
5.2.1 Top Task Bar	37
5.2.1.1 Panel Buttons	37
5.2.1.2 Case Information	37
5.2.2 Bottom Task Bar	38
5.2.2.1 Menu	38
5.2.2.2 Camera	39
5.2.2.3 Snapshot	39
5.2.2.4 HKA	39
5.2.2.5 Distal Viewer	40
5.2.2.6 Bone Reference Checkpoint (optional)	40
5.3 Robotic Modes	41
5.4 Robotic Positions	41
5.5 Application Audio Notifications	42
5.6 Application Visual Notifications	42
5.7 ROSA Knee Application-SURGEON Panel	44
5.7.1 Femoral Rotation Axis Display	45
5.7.2 Knee State Evaluation	45
5.7.3 Femoral Rotation Tool	45
5.7.4 Flexion Angles for Stress Tests	45
5.7.5 Bone Reference Checkpoint	45
5.7.6 Kinematic Alignment (Persona CR Only)	46
5.7.7 Active Track	46

6. ROSA Knee Application-SETUP Panel.....	47
6.1 OR Setup	47
6.2 Calibration of Sensor	47
6.3 Draping	48
6.4 Touchscreen Monitor Draping	49
6.5 Tracker Calibration	49
6.6 ROSA Knee Positioning	50
6.7 Camera Positioning	51
6.8 ROSA Knee Registration	51
6.9 Bone References.....	52
6.9.1 Femoral Bone References	52
6.9.1.1 2 Pins References Femur TS3 P/N: 20-8000-010-33....	52
6.9.1.2 ROSA Polyaxial Reference Size 3 (Femur) P/N: 20-8020-037-00	53
6.9.2 Tibial Bone References	56
6.9.2.1 ROSA Tibia Reference A/B.....	56
6.9.2.2 ROSA Polyaxial Reference Size 6 (Tibia) P/N: 20-8020-038-00	57
6.9.2.3 Offset 2 Pins Reference Tibia P/N: 20-8000-010-35/20-8000-010-36	58
6.10 Visibility Guidelines.....	59
7. ROSA Knee Application-FEMUR Panel	60
7.1 Femoral Head Center	60
7.2 Femoral Axis Point	61
7.3 Femur Checkpoint (Optional)	61
7.4 Posterior Condyles.....	61
7.5 Anterior and Posterior Trochlear Groove.....	62
7.6 Medial and Lateral Epicondyles	62
7.7 Medial and Lateral Distal Condyles.....	62
7.8 Anterior Cortex	63
7.9 Femur Wear Evaluation	63
7.10 FEMUR Panel-Error Notifications	64
8. ROSA Knee Application-TIBIA Panel.....	65
8.1 Tibia Checkpoint (Optional)	65
8.2 Malleoli.....	66
8.3 Medial Third Tubercle	66
8.4 Tibial Axis Point	66
8.5 PCL Insertion Point	66
8.6 Medial and Lateral Plateau Resection References	66
8.7 Medial and Lateral PTA Reference	67
8.8 Tibia Wear Evaluation	67
8.9 TIBIA Panel-Error Notifications	67

9. ROSA Knee Application-EVALUATION Panel (Optional)	68
10. ROSA Knee Application-PLANNING Panel	71
10.1 PLANNING Panel Overview.....	71
10.1.1 Implant Selection	71
10.1.2 Implant Manipulator.....	72
10.1.3 Frontal View	72
10.1.4 Lateral View	73
10.1.5 Tibia Axial View	73
10.2 Viewing Options	74
10.3 Balance Tool	75
10.4 Femoral and Tibial Components Planning	76
10.5 OptimiZe Planning feature	77
10.6 PLANNING Panel-Error Notifications	78
10.7 PLANNING Limits	78
11. ROSA Knee Application-RESECTIONS Drawer	80
11.1 RESECTIONS Drawer Overview.....	80
11.2 ROSA TKA Cut Guide Installation and Checkpoints.....	82
11.3 Femoral Distal Resection.....	82
11.4 Tibial Proximal Resection.....	86
11.5 Femoral Rotation (Optional)	88
11.6 Femoral 4-in-1 Resection.....	89
11.7 Checkpoint Screw Removal	91
11.8 RESECTIONS Drawer-Error Notifications.....	91
11.9 Final Knee State Evaluation (Optional)	92
11.10 Confirm Data	92
11.11 Removal of Instrumentations.....	92
12. Robotic Errors	93
13. Post-operative Guide/Maintenance	95
13.1 Retrieval of Post-Surgical Log File	95
13.1.1 Surgeon Report.....	95
13.1.2 Investigation Logs.....	95
13.2 Shutdown	96
13.3 Cleaning, Disinfection and Sterilization	96
13.3.1 Cleaning the Robotic and Optical Units	96
13.3.2 Cleaning the Optical Camera.....	97
13.3.3 Instruments Reprocessing (Cleaning and Sterilization Methods)	97
13.3.3.1 Sterilization Parameters	98
13.3.3.2 ROSA Knee System Instrument Kit.....	98
13.3.3.3 ROSA Knee System Instrument Lifetime Expectancy...	102
13.4 Storage and Transport	102
13.4.1 Storage and Protection	102
13.4.1.1 Device Storage and Protection	102
13.4.1.2 Instruments Storage and Protection.....	102

13.4.1.3 Care of Cables and Connectors.....	102
13.4.2 Transport.....	103
13.4.2.1 Device Transport	103
13.4.2.2 Transport of ROSA Checkpoint Screws	103
13.5 Maintenance Operations.....	104
13.5.1 Installation	104
13.5.2 Safety Checks.....	104
13.5.3 Periodic Maintenance	104
13.6 Troubleshooting.....	105
13.7 Safe Disposal	108
14. Product Security Customer Control Considerations.....	109
14.1 Records Retention & Purging Historical Data	109
14.2 Physical & Environmental Security Controls	109
14.3 Cybersecurity Controls	109
15. Technical Data.....	110
15.1 Labels & Symbols	110
15.1.1 Labels	110
15.1.2 Symbols on the Labels.....	113
15.1.3 Other Symbols on the Device	115
15.2 Technical Specifications	117
15.2.1 Environmental Specifications	117
15.2.2 Device Performance	117
15.2.3 Device Dimensions	118
15.2.4 Robotic Arm Working Range.....	119
15.3 Safety Classification & Standards	119
15.3.1 Cable Lengths.....	119
15.4 Electromagnetic Compatibility	121
15.4.1 Electromagnetic (EM) Emissions	121
15.4.2 Electromagnetic and Magnetic Immunity	122
15.4.3 Electromagnetic Immunity and Portable and Mobile Radio Frequency (RF) Communication Equipment	124
15.4.4 Recommended Separation Distances	125
16. Software Licenses.....	126
16.1 Boost	126
16.2 VTK	126
16.3 GDCM	127
16.4 ITK.....	127
16.5 Open SSL.....	129
16.6 JSON.....	131
16.7 Eigen	131
Appendix A: Supported Implants and A/P Referencing of the ROSA Knee System	136
Appendix B: Implant Compatibility Between Femoral and Tibial Component Brands	139
Appendix C: Implant Compatibility Between Femoral and Tibial Component Sizes	140

1. General Information

1.1 Conventions

This document employs the following conventions:

 **WARNING:** This symbol is present when a warning alerts you to a potential danger to health or life.

 **CAUTION:** This symbol is present to prevent a risk of deterioration of the equipment in case of a handling error.

 **REMARK:** This symbol is present to provide a general observation or information related to procedures, events or practices that are recommended or essential for a successful operation.

1.2 ROSA Knee System Description

The ROSA[®] Knee System is used to assist surgeons in performing Total Knee Arthroplasty (TKA) with features to assist with the bone resections, as well as assessing the state of the soft tissues to facilitate implant positioning intra-operatively.



The ROSA Knee System uses a case management system called the ZB Edge Case Portal[®] (ZBCP), which manages the creation and tracking of the surgical case. The case resides on the portal until it is uploaded to the ROSA Knee System before surgery. If the case is image-based, a 3D virtual bone model is generated pre-operatively by the PSI system (uses X-Atlas[®] 2D to 3D Technology) to create a model of the patient's femur/tibia and allows the preparation of a pre-operative surgical plan.

1.2 ROSA Knee System Description (cont.)

The intra-operative workflow and surgical concepts implemented in the system remain close to the conventional TKA workflow. As such, at the time of the surgery and based on the surgical plan, the system mainly assists the surgeon in determining reference alignment axes in relation to anatomical landmarks, in planning the orthopedic implant's location based on these reference alignment axes and orthopedic implant geometry, in assisting in joint balancing and in precisely positioning the Cut Guide relative to the planned orthopedic implant location by using a Robotic Arm.

CAUTION: Federal Law restricts this device to sale by or on the order of a physician.

1.3 Contact

Zimmer CAS

75, Queen Street, Suite 3300

Montreal (Quebec), H3C-2N6 CANADA

Tel.: +1-514-396-5422

ROSA Knee System Customer service: +1-514-396-5422, +1-866-3D-ORTHO

zimmerbiomet.com

Note, ROSA trained ZB representatives are available physically or on ROSA Knee System Customer service.

1.4 Training

This device is a surgery assistance tool. It should only be used by authorized surgeons and healthcare professionals trained in the use of the device by Zimmer Biomet or by personnel authorized by Zimmer Biomet. It is not a replacement for the surgeon's expertise and experience. In support of the authorized surgeon user, a Zimmer Biomet ROSA Specialist or trained support staff will help operate the ROSA Knee Touchscreen Display and help position the Optical Camera and/or Optical and Robotic Units at the direction of the surgeon user and will provide User Manual information during the surgical procedure.

1.5 Intended Use

The ROSA Knee System, for use with the ROSA® Recon Platform, is intended to assist the surgeon in providing software-defined spatial boundaries for orientation and reference information to anatomical structures during orthopedic surgery procedures. The system can also be used to assist in joint balancing techniques.

DISCLAIMER: The device must only be used for its intended use.

1.6 Indications For Use

The ROSA Knee System, for use with the ROSA Recon Platform, is indicated as a stereotaxic instrumentation system for total knee replacement (TKA) surgery. It is to assist the surgeon in providing software-defined spatial boundaries for orientation and reference information to identifiable anatomical structures for the accurate placement of knee implant components.

The Robotic Arm placement is performed relative to anatomical landmarks as recorded using the system intra-operatively, and based on a surgical plan, optionally determined pre-operatively using compatible X-ray-based surgical planning tools.

It includes a Robotic Arm, an optical tracking system and accessories, software system, surgical instruments and accessories.

The ROSA Knee System is designed for use on the skeletally mature patient population. The targeted population has the same characteristics as the population that is suitable for the implants compatible with the ROSA Knee System.

The ROSA Knee System is to be used with the following fixed bearing knee replacement systems in accordance with their indications and contraindications: NexGen® CR, NexGen CR-Flex, NexGen CR-Flex Gender, NexGen LPS, NexGen LPS-Flex, NexGen LPS-Flex Gender, Persona® CR, Persona PS, Persona Ti-Nidium® CR, Persona Ti-Nidium PS, Persona® PPS® CR, Persona® PPS® PS, Persona SoluTion PPS, Persona IQ®, Vanguard® CR, and Vanguard PS.

When Kinematic Alignment approach is used with the ROSA Knee System, it is highly recommended to reference the Personalized Alignment Surgical Technique (1578-GLBL-en) and follow the indications/
 contraindications found within that include (but are not limited to): Persona[®] CR Implant System with the Cruciate Retaining (CR), Medial Congruent (MC), or Ultra Congruent (UC) Bearing and cemented femoral and tibia components without a stem extension. Preservation of the PCL is preferred.

1.7 Contraindications

The ROSA Knee System may not be suitable for use in case of:

- Hip pathology with significant bone loss (e.g. avascular necrosis of the femoral head with collapse, severe dysplasia of the femoral head or the acetabulum)
- Hip pathology severely limiting range of motion (e.g. arthrodesis, severe contractures, chronic severe dislocation)
- Active infections of the knee joint area
- Knee replacement revision surgery
- Presence of strong infrared sources or infrared reflectors in the vicinity of the NavitrackER devices
- Implants that are not compatible with the system
- Contraindications for the implant as given by the implant manufacturer

1.8 Complications

Possible complications associated with the use of the ROSA Knee System may include but are not limited to the following:

- Infection
- Implant misalignment
- Unstable joint due to erroneous soft tissue balancing

1.9 Restrictions For Use

The ROSA Knee System described in this User Manual should not be used in combination with other products or components unless such other products or components are expressly recognized as compatible with ROSA Knee System. The list of compatible instruments is provided in section 3.3.3.

- The ROSA Knee System should not be used to perform surgery in applications other than those specified in this User Manual

 The device must only be used after reading this User Manual and after receiving the appropriate training. Please contact Zimmer Biomet's Customer Service if unsure how to use the device.

 MR Unsafe: Keep away from Magnetic Resonance Imaging (MRI) Equipment.

1.10 Patents

Patents available online at zimmerbiomet.com/patents

2. About This Manual

This User Manual provides detailed information about the ROSA Knee System. Further, in this document, the ROSA Knee System can be referred to as “the device”. This manual is considered as the reference document for users. It is not a technical maintenance or service manual. For technical instructions about the device, please contact Zimmer Biomet’s Customer Service or one of its approved representatives. A troubleshooting guide is provided in Chapter 13- Post-operative Guide/Maintenance of this manual (section 13.6).

-  The device must only be used after reading this User Manual and after receiving the appropriate training. Please contact Zimmer Biomet’s Customer Service if unsure how to use the device.







DISCLAIMER: The device must only be used for its intended use.

2.1 Safety



2.1.1 Warnings, Cautions and Remarks

The correct use of this equipment implies that all the operating staff are familiar with the Instructions for Use. This manual must be carefully studied before using the device. Particular attention must be paid to the safety instructions related to people and the device.





Training, Use and Maintenance

-  Only properly trained, qualified personnel with appropriate credentials should operate the device. Users must follow safety guidelines and warnings.
-  The device must only be used after reading this User Manual and after having received the appropriate training. Please contact Zimmer Biomet’s Customer Service if unsure how to use the device.
-  Do not open the device. In case of any issue or breakdown, do not intervene. Maintenance and service operations must only be carried out by Zimmer Biomet’s Customer Service or any of its approved representatives. Do not modify the device.
-  Never attempt to clean the device when it is connected to a power supply. To avoid electrical discharges, always unplug the device from the wall outlet before cleaning or disinfecting it.
-  A knee positioner, such as the De Mayo Knee Positioner®, is recommended to be used with the ROSA Knee System, otherwise accuracy may be impacted.
-  When used in compliance with the indications for maintenance, the device can be used as intended
-  In the presence of an HVAC system, ensure that the Robotic Unit or Optical Stand is not positioned in the way of the expelled airflow, as it can influence the stability of the camera readings.

Electrical Safety







-  In order to avoid any risk of electric shock, the device must only be connected to an electric power network equipped with grounding. Device is class I, type BF.
-  Do not simultaneously touch the patient and any component of the device other than those attached to the electrical isolation interface part.
-  When using the robotic surgical instruments of the ROSA Knee System in combination with other medical electrical (ME) equipment the patient leakage currents from multiple devices could create an additive effect.

2.1.1 Warnings, Cautions and Remarks (cont.)







-  IPX0 Protection: Device without special protection against the penetration of liquids. Do not pour any liquid over the device.
-  Do not exceed the recommended input voltage for the device. Plugging the device to a higher voltage supply could damage the device.
-  In order to prevent accidental detachment of connectors, ensure the metallic ring is attached to the Robotic Unit's hook, if applicable.
-  Verify the metallic ring of the Optical Unit Cable is attached to the hook on the Rear Panel of the Robotic Unit to ensure electromagnetic compatibility (EMC) protection, if applicable.
-  Do not connect any elements to the Robotic Unit other than those provided with the device.

Radiation Safety

Risks generated by laser beam exposure: The device uses a laser integrated into the navigation camera.

-  This laser is of class 2 (power inferior to 1 mW, eye protection by the palpebral reflex). Do not orient the laser beam to the eyes or to any light-reflecting surfaces (such as mirrors) to avoid any direct or indirect exposure to laser beam.
-  Do not orient the laser towards the patient's eyes, the user's eyes or anyone else's eyes.
-  MR Unsafe: Keep away from Magnetic Resonance Imaging (MRI) Equipment.
-  The device requires specific precautions regarding the EMC. It must be set up and initiated according to the EMC information provided in this User Manual.
-  Portable and mobile radio frequency communication devices might affect the operation of the device.
-  Usage of accessories, transducers and cables other than those specified in the User Manual, with the exception of the transducers and cables sold by Zimmer Biomet (as spare parts of internal components), might cause increased emissions or decreased immunity of the device.
-  The device must not be used adjacent to or stacked on top of any other equipment. If necessary, verify its correct operation in the corresponding configuration.









Risks Related to Transport and Immobilization

-  Ensure that the Robotic Unit is not moving once the immobilization system is locked.
-  Risk of pinching: Do not place fingers or feet under the stabilization feet before immobilization of the system.
-  Verify the position of the device and its environment when using the Robotic Unit immobilization system.
-  During transportation, the device can be immobilized by activating the Immobilization Pedal. Do not install the device on an inclined surface, unless stability is guaranteed.
-  During transportation or set up, do not roll the Robotic Unit and/or Optical Unit wheels over the cables or cable connectors to avoid potential damage.
-  The Robotic Unit and Optical Unit wheels are equipped with cable pusher(s), which are safety features to avoid rolling over cables and possibly damaging them. They are designed to be compatible with standard OR floors.



2.1.1 Warnings, Cautions and Remarks (cont.)

-  In the event that the cable pushers are removed by Zimmer Biomet-approved representatives, such as a Field Service Engineer/Field Service Provider, upon a special request from HDO (e.g. due to incompatible/soft flooring, etc.), care must be taken to not roll the device over cables/connectors during use (e.g., immobilization, transportation/storage and set up).

Mechanical Safety













-  Ensure that the Foot Pedal is operating correctly before beginning a procedure. Visually inspect the device and perform a test for interruption/resumption of a Robotic Arm movement.
-  Risk of collision: When the Robotic Unit is in Automatic mode, stay clear of the Robotic Arm and its path to the next position.
-  Risk of arm dropping-off: Do not lean on the Robotic Arm.
-  Risk of pinching: Do not place fingers in accessible parts of the plastic covers of the Robotic Arm.
-  Risk of tracking interruption: Avoid passing obstacles between the camera and the bone reference or the Robotic Unit reference.
-  Risk of navigation camera motion: Do not lean on the camera support arm.
-  The operating table must not be moved once an instrument guided by the Robotic Unit is connected to the patient anatomy.
-  Test the Tracking mode before any instrument guided by the Robotic Unit is connected to the patient anatomy.

Instruments

- Before every surgery, the user must verify that all instruments have been sterilized. Be aware of the contamination and potential consequent infection risk associated with the complexity of instruments and robotic components (overall geometry, features, sharp edges). Failure to follow the cleaning and sterilization instructions may result in contamination leading to patient infection and organ failure or dysfunction.
-  Ensure the packaging integrity (shelf box, outer package, inner package and foil pouch) and shelf life date validity and sterility indicator. Failure to do so may result in contamination leading to organ failure or dysfunction.
- For reusable instruments, also refer to the instrument's package insert and Reusable Instrument Lifespan Manual. Be aware of the contamination and potential consequent infection risk associated with the complexity of instruments and robotic components (overall geometry, features, sharp edges). Failure to follow the cleaning and sterilization instructions may result in contamination leading to patient infection and organ failure or dysfunction.
-  Verify the integrity of all the instruments prior to each surgery. Visually inspect the instruments for damages. For reusable instruments, also refer to the instrument's package insert and Reusable Instrument Lifespan Manual.
-  Verify the proper fixation of the NavitrackER devices on each instrument (ROSA Base & Arm Reference Frame, ROSA Registration Pointer, Bone References and Universal Validation Tool Body). Always use the NavitrackER pliers for installation.

2.1.1 Warnings, Cautions and Remarks (cont.)

Instruments

-  Verify the proper fixation of the percutaneous pins in the patient's bone anatomy (femur and tibia).
-  Verify the proper fixation of the bone references on the pins (femur and tibia). The bone references are secured on the pins, close to the patient's skin (without compression), using two hexagonal screws.
-  Bone references **MUST** be firmly attached to the bone and **MUST NOT** move at any point during surgery. If a bone reference has moved, the landmarks digitized on that bone must be digitized again.
-  Verify the knobs of the Polyaxial References are firmly tightened with the Screwdriver and **DO NOT** loosen at any point during surgery. If a bone reference has moved, the landmarks digitized on that bone must be digitized again.
-  Do not remove the ROSA Pin Stabilizer from the pins. Its use is mandatory throughout the entire surgery when the ROSA Polyaxial Reference Size 3 (femur) is fixed outside the incision.
-  Do not use any Optical Trackers other than those provided by Zimmer Biomet.
-  Always verify the proper installation of an instrument to the Robotic Unit or Robotic Arm by making sure screws are firmly tightened.
-  Verify the proper assembly of the Universal Validation Tool Body and the Distal & Posterior Condyles Digitizer before the acquisition of the posterior condyles or before validating the tibial proximal resection.
-  Verify the proper assembly of the Universal Validation Tool Body and the ROSA Condyle Digitizers before the acquisition of the posterior condyles.
-  Verify the proper assembly of the Universal Validation Tool Body and the ROSA Tibia Validation Tool before validating the tibial proximal resection.
-  When configuring the ROSA Knee System, ensure that all additional medical electrical (ME) equipment integrated into the system configuration also adheres to the safety standards for F-TYPE applied parts.
-  Before every surgery, the user must verify that the ROSA Knee System is compatible with all surgical instruments and other applied parts, including those of other medical electrical (ME) equipment as per Section 2.1 Safety.
-  When using the ROSA Knee System together with accessories, other medical electrical (ME) equipment and non-medical electrical equipment within the robotic surgery configuration, ensure that all components are compatible and safe to use.
- Handle instruments with care. Avoid dropping instruments. Damage to an instrument can have a significant effect on the accuracy of the procedure and consequently, on the post-operative surgical outcome.

At the end of the procedure, instruments are placed in their tray for sterilization. Be aware of the contamination and potential consequent infection risk associated with the complexity of instruments and robotic components (overall geometry, features, sharp edges).

Failure to follow the cleaning and sterilization instructions may result in contamination leading to patient infection and organ failure or dysfunction.
-  Do not apply excessive torque on screws when installing an instrument. Do not use power tools.

2.1.1 Warnings, Cautions and Remarks (cont.)

Note: Devices: The components in the table below contain the following substances defined as CMR 1A and/or CMR 1B substances in concentration above 0.1% weight by weight:

- Cobalt; CAS No. 7440-48-4; EC No. 231-158-0

The applicable components are identified on the product label with the  symbol.

Current scientific evidence supports that medical devices manufactured from cobalt alloys or stainless steel alloys containing cobalt do not cause an increased risk of cancer or adverse reproductive effects.

Component Name	Part Number
Universal Validation Tool Body	20-8000-010-06
Distal & Posterior Condyles Digitizer	20-8000-010-17
2 Pins Reference Femur TS3	20-8000-010-33
ROSA Tibia Reference A	20-8020-028-00
ROSA Tibia Reference B	20-8020-029-00
Offset 2 Pins Reference Right Tibia Size 6	20-8000-010-35
Offset 2 Pins Reference Left Tibia Size 6	20-8000-010-36
ROSA Persona TKA Cut Guide A	20-8020-007-00
ROSA Persona TKA Cut Guide B	20-8020-008-00
ROSA NexGen TKA Cut Guide A	20-8020-009-00
ROSA NexGen TKA Cut Guide B	20-8020-010-00
ROSA Vanguard TKA Cut Guide A	20-8020-011-00
ROSA Vanguard TKA Cut Guide B	20-8020-012-00
ROSA Registration Pointer	20-8020-013-00
ROSA Polyaxial Reference Size 3	20-8020-037-00
ROSA Polyaxial Reference Size 6	20-8020-038-00
ROSA Pin Stabilizer, 60mm	20-8020-039-00
ROSA Stabilizer Tissue Deflector, 60mm	20-8020-040-00
ROSA Knee Condyle Digitizer, Small	20-8020-190-00
ROSA Knee Condyle Digitizer, Medium	20-8020-191-00
ROSA Knee Condyle Digitizer, Large	20-8020-192-00
ROSA Knee Tibia Validation Tool	20-8020-193-00

2.1.1 Warnings, Cautions and Remarks (cont.)

Contamination

 The device must be used with sterile drapes. These drapes must be installed in accordance with the instructions detailed in this User Manual. Failure to do so may result in contamination leading to potential patient infection and organ failure or dysfunction.

 Verify the setup of the sterile drapes before beginning a surgery to ensure the asepsis of the surgical field.

Use of the Application in Collaborative Mode

 Continue pressing the Foot Pedal when pinning, resecting with Active Track or drilling in Collaborative mode to enable Bone Tracking mode, otherwise accuracy may be impacted. Visual and audio notifications are provided if the Foot Pedal is released in Collaborative mode.

Specific Caution for the United States of America

CAUTION: Federal Law restricts this device to sale by or on the order of a physician.

3. Description

3.1 Overview

The ROSA Knee System is a robotic platform that aims at assisting orthopedic surgeons with the bony resections as well as assessing the state of the soft tissues to facilitate implant positioning during a total knee arthroplasty. Surgical planning software can be used pre-operatively by the surgeon to plan implant positioning and sizing. The surgeon may also use the imageless option within the ROSA Knee System to achieve the same goal as an image-based case.

The device is composed of two units, one positioned on each side of the operating table:

- Robotic Unit consisting of a compact Robotic Arm and a Touchscreen
- Optical Unit and a Touchscreen

The intra-operative workflow and surgical concepts implemented in the system remain close to the conventional TKA workflow. As such, at the time of the surgery and based on the surgical plan, the system mainly assists the surgeon for:

- Determining reference alignment axes in relation to anatomical landmarks
- Planning the orthopedic implant's location based on these reference alignment axes and orthopedic implant geometry
- Assisting in joint balancing
- Precisely positioning the Cut Guide relative to the planned orthopedic implant location by using a Robotic Arm



ROSA Knee System

3.2 Operating Principle

The operating principle for a total knee arthroplasty procedure is described below.

3.2.1 Case Information

The case is launched with a USB drive plugged into the Robotic Unit using the case management application. The welcome screen of the application confirms the patient ID, procedure laterality, implant family and instrumentation. Once the user has confirmed the information, the ROSA Knee application can be launched.

3.2.2 Pre-operative Planning

Image-based cases

The patient's knee, reconstructed in 3D using pre-operative X-rays, can be used for the preparation of a pre-operative plan. In this case, a patient-specific 3D bone model will be displayed on some panels.

 If the registration of the landmarks taken intra-operatively and the patient knee reconstructed in 3D is unsuccessful, the user will have the possibility to redo the landmarks or switch to an imageless case.

Imageless cases

If desired, the surgeon can decide not to plan the surgery prior to the surgery date and use the ROSA Knee System intra-operatively. In this case, generic bone schematics will be displayed in the user interface.

 If a Persona IQ[®] implant is used, please refer to the Pre-operative Planning sections of the Persona IQ Surgical Technique (K01-CTE-300005) for implant size +58 mm and to (K05-STB-300005) for implant size +30 mm.*

3.2.3 OR Setup

The patient is placed on the surgical table in supine position. The Robotic Unit is positioned approximately at the patient's hip and approximately 45° relative to the surgery table. Two patient bone references are installed on the patient's femur and tibia as a reference for leg movements. A third reference is located on the Robotic Unit (on the post of the ROSA Base Reference Bar closest to the surgical table) to track where the Robotic Unit is relative to the patient's leg during the surgery.

 In the presence of an HVAC system, ensure that the Robotic Unit or Optical Stand is not positioned in the way of the expelled airflow, as it can influence the stability of the camera readings.

 During the surgery, the surgeon must always stay on the same side as the Robotic Unit.

 The maximum height of the patient on the OR table must be 44 inches to minimize tracker visibility problems. In case of a patient with a high BMI, lower the table to avoid visibility problems.

There are four possible OR setups:

- Operating on a right knee, with the surgeon on the same side as the operated knee
- Operating on a right knee, with the surgeon on the opposite side of the operated knee
- Operating on a left knee, with the surgeon on the same side as the operated knee
- Operating on a left knee, with the surgeon on the opposite side of the operated knee

*K01-CTE-300005, and K05-STB-300005 may be found on the Canary Medical website: canarymedical.com

Right Knee

Left Knee

Surgeon same side as the operated knee

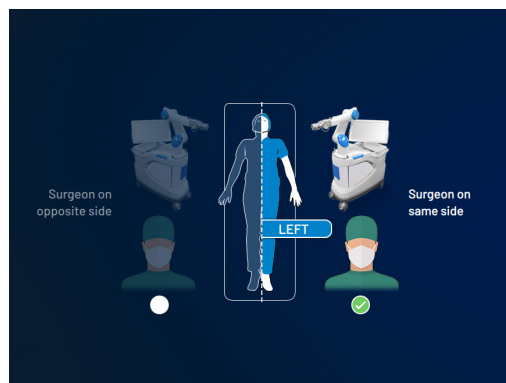
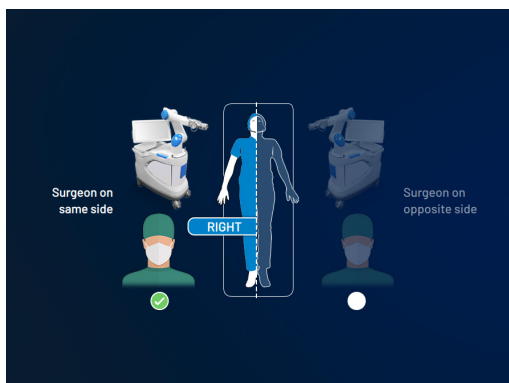

Surgeon opposite side of the operated knee

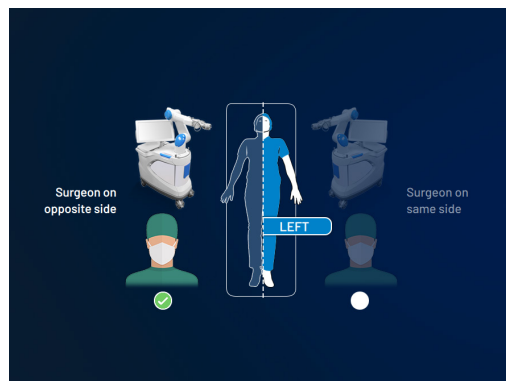
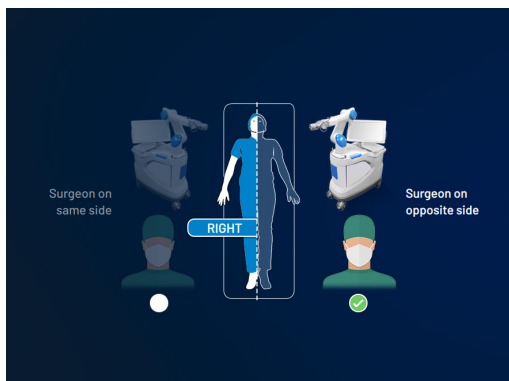

Possible OR Setups

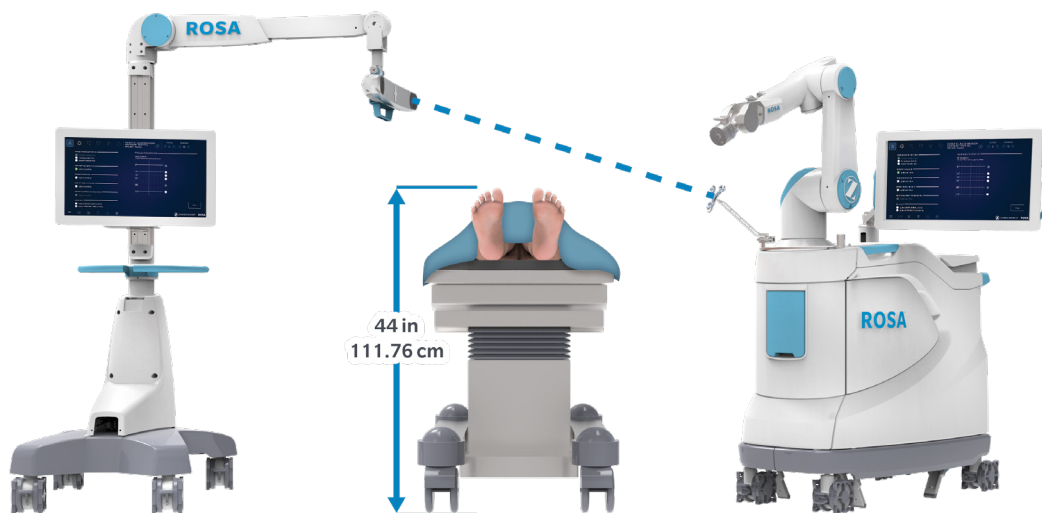

Maximum Height of Patient to Minimize Tracker Visibility Problems

3.2.4 Robotic Unit Registration

Registration of the Robotic Unit is performed with a fourth reference mounted on the Robotic Arm prior to the start of the surgery. This ensures the functional verification of the Robotic Arm prior to the start of the surgery. The patient should be in the OR for this step.

3.2.4 Robotic Unit Registration (cont.)

 Risk of collision: When the Robotic Unit is in Automatic mode, stay clear of the Robotic Arm and its path to the next position.

3.2.5 Bony Landmarks & Navigation

Using a registration pointer, the surgeon will digitize the bony landmarks to record the patient leg coordinate system. The surgeon may also digitize the Checkpoint Screw (optional). Throughout the surgery, real-time tracking of patient movement is provided by the optical tracking system.

3.2.6 Planning

If not done pre-operatively, the surgeon can set his surgical plan intra-operatively, i.e. the femur and tibia bone cuts, according to preferences (including Personalized Alignment) and the chosen implant components.

 If a Persona IQ implant is used, please refer to the Pre-operative Planning sections of the Persona IQ Surgical Technique (K01-CTE-300005) for implant size +58 mm and to (K05-STB-300005) for implant size +30 mm.*

3.2.7 Surgery

Based on the intra-operative planning values, the Robotic Arm will move to reach the appropriate positions to execute the bone resections.

 Risk of collision: When the Robotic Unit is in Automatic mode, stay clear of the Robotic Arm and its path to the next position.

If the Femoral Rotation Assessment (optional) is selected, the ROSA Knee System provides clinical information to assist the surgeon in setting up the femoral rotation, taking into consideration the condition of the knee (medial and lateral gaps).

3.3 System Description

3.3.1 Robotic Unit

The Robotic Unit is composed of the following main components:

- Robotic Arm
- Touchscreen for operating the device
- Immobilization system
- Foot Pedal
- Computer and software

The Robotic Unit is equipped with swivel wheels and handles allowing the device to be easily moved from one operating room to the other by a single person. The wheels are equipped with foot pressure brakes to lock the unit in place and cable pushers to avoid rolling on cables.

It has optional lateral openings and a sliding shelf providing storage for various items. A fixed bar (ROSA Base Reference Bar) on the front side of the Robotic Unit is used to install the ROSA Base Reference Frame.

*K01-CTE-300005, and K05-STB-300005 may be found on the Canary Medical website: canarymedical.com.

3.3.1 Robotic Unit (cont.)

The Robotic Unit is powered by the operating room power supply by plugging the Power Cable from the Rear Panel into a power plug compatible with the device characteristics.

The Foot Pedal is linked to the Robotic Unit by plugging the cable to the dedicated connector on the Rear Panel.

The Robotic Unit Power Cable and Foot Pedal cable can be rolled around rollers on the Rear Panel. The Foot Pedal may also be stored in the storage area.



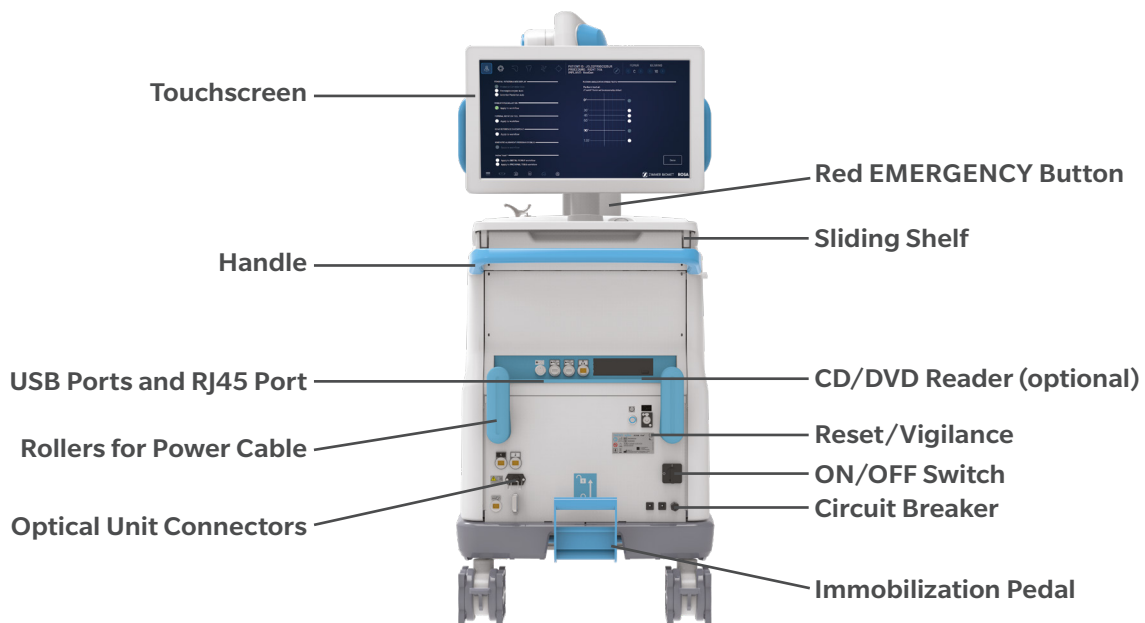



Rear Panel

3.3.1 Robotic Unit (cont.)

The Rear Panel includes:

- Main ON/OFF switch to turn on and off the device
- RESET button to restart the PC
- CIRCUIT BREAKER button to restart the device after it has been turned off to an overvoltage
- Connectors to plug in the Optical Unit and the Foot Pedal
- USB ports to import cases. CD/DVD reader is unplugged and non-functional. One USB port is available in the storage area beneath the sliding shelf to connect a mouse
- RJ45 port to connect the system to an intra-operative imaging system (deactivated)
- Controller servicing port (deactivated)
- Laser button (deactivated)

 Do not connect any elements to the Robotic Unit other than those provided with the device.

 In order to prevent accidental detachment of connectors, ensure the metallic ring is attached to the Robotic Unit's hook, if applicable.

 Make sure the metallic ring of the Optical Unit Cable is attached to the hook on the Rear Panel of the Robotic Unit in order to ensure EMC protection, if applicable.

3.3.1.1 Robotic Arm

The Robotic Arm is equipped with a Force Sensor that manually moves the Robotic Unit to the desired location by measurement of forces exerted at the end of the arm and a compensation principle, regardless of the instrument used.



3.3.1.2 Touchscreen

The device includes two Touchscreens that display the user interface, one on the Robotic Unit and one on the Optical Unit.



3.3.1.3 Immobilization System



The Robotic Unit is equipped with a system immobilizing it to the ground. This system is composed of four stabilization feet, activated by a pedal. Two positions are available: the unit is immobilized when the pedal is down or the unit is mobile when the pedal is up. Additionally, each wheel of the Robotic Unit can be locked individually.



Pedal in Down Position Immobilized



Pedal in Up Position Mobile

-  Risk of pinching: Do not place fingers or feet under the stabilization feet before immobilization of the system.
-  Verify the position of the device and its environment when using the Robotic Unit immobilization system. Make sure cables or wires are cleared from the area of the stabilization feet to prevent damage.

3.3.1.4 Vigilance Device (Foot Pedal)

The device is equipped with a Foot Pedal that enables the Robotic Arm movements. The Robotic Arm will only move if the user presses the Foot Pedal. This operating principle applies to the SETUP and RESECTIONS panels. The Robotic Arm movement is interrupted as soon as the user releases the Foot Pedal. The pressed Foot Pedal is also necessary in the FEMUR Panel to record the painting of the Medial and Lateral Distal Condyles landmark.

-  The Foot Pedal is also used in the KNEE STATE EVALUATION panel to record varus/valgus and laxity of the knee. When the Foot Pedal is pressed, values will be recorded. When the Foot Pedal is released, values will not be recorded.



Vigilance Device (Foot Pedal)

-  Ensure that the Foot Pedal is operating correctly before beginning a procedure. Visually inspect the device and perform a test for interruption/resumption of Robotic Arm movement.

3.3.2 Optical Unit

The Optical Unit is composed of:

- Optical Camera
- Camera Positioning Arm
- Touchscreen

! Risks generated by laser beam exposure: The device uses a laser integrated into the Optical Camera. This laser is of class 2 (power inferior to 1 W, eye protection by the palpebral reflex). Do not orient the laser beam to the eyes or to any light-reflecting surfaces (such as mirrors) to avoid any direct or indirect exposure to laser beam.

! Do not orient the laser towards the patient's eyes, the user's eyes or anyone else's eyes.

The Optical Unit is powered by the Robotic Unit by plugging the cable into the connector on the Robotic Unit Rear Panel. A roller is included to properly store the Optical Unit Cable. The Optical Unit is equipped with swivel wheels and a handle allowing the device to be easily moved from one operating room to the other by a single person. Each wheel has a brake and a cable pusher system. A laser is integrated into the camera to facilitate the camera positioning and orientation adjustments during the device installation in the operating room.

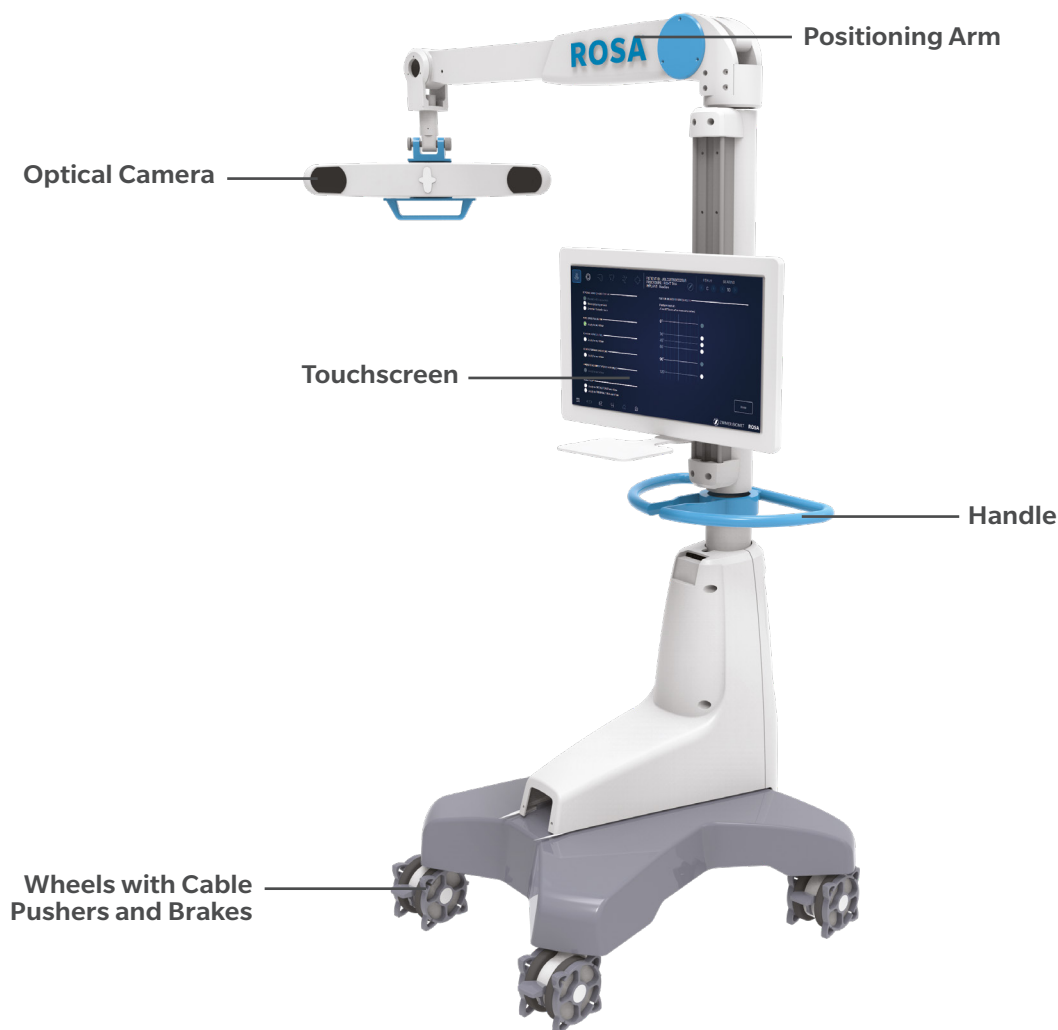

3.3.3 Instrumentation

ROSA Knee Instruments

All reusable instruments need to be sterilized before each use.

Component's Name	Part Number
Instrument Case Lid	110031221
3.5 mm Hex Head Screwdriver	00-5120-087-00
Universal Validation Tool Body	20-8000-010-06
Distal & Posterior Condyles Digitizer	20-8000-010-17
2 Pins Reference Femur TS3	20-8000-010-33
ROSA Tibia Reference A	20-8020-028-00
ROSA Tibia Reference B	20-8020-029-00
Offset 2 Pins Reference Right Tibia Size 6	20-8000-010-35
Offset 2 Pins Reference Left Tibia Size 6	20-8000-010-36
NavitrackER Pliers	20-8000-070-05
ROSA Base Reference Frame	20-8020-002-00
ROSA Arm Instrument Interface	20-8020-004-00
ROSA Persona TKA Cut Guide A	20-8020-007-00
ROSA Persona TKA Cut Guide B	20-8020-008-00
ROSA NexGen TKA Cut Guide A	20-8020-009-00
ROSA NexGen TKA Cut Guide B	20-8020-010-00
ROSA Vanguard TKA Cut Guide A	20-8020-011-00
ROSA Vanguard TKA Cut Guide B	20-8020-012-00
ROSA Registration Pointer	20-8020-013-00
ROSA Arm Reference Frame	20-8020-015-00
ROSA Polyaxial Reference Size 3	20-8020-037-00
ROSA Polyaxial Reference Size 6	20-8020-038-00
ROSA Pin Stabilizer, 60mm	20-8020-039-00
ROSA Stabilizer Tissue Deflector, 60mm	20-8020-040-00
ROSA Knee Persona Kit	20-8020-060-00
ROSA Knee Persona ID Plate	20-8020-060-01
ROSA Knee NexGen Kit	20-8020-061-00
ROSA Knee NexGen ID Plate	20-8020-061-01
ROSA Knee Vanguard Kit	20-8020-062-00
ROSA Knee Vanguard ID Plate	20-8020-062-01
Trocar Screw Pin Driver	00-5901-021-00
ROSA Knee Condyle Digitizer, Small	20-8020-190-00
ROSA Knee Condyle Digitizer, Medium	20-8020-191-00
ROSA Knee Condyle Digitizer, Large	20-8020-192-00
ROSA Knee Tibia Validation Tool	20-8020-193-00
ROSA® Knee Tray	20-8020-064-00
ROSA® Knee Instrument Case	20-8020-063-00
ROSA Knee General Instrument Case	20-8020-065-00
ROSA Knee Modular Instrument Case	20-8020-066-00
ROSA Modular Tray	20-8020-067-00
ROSA Pin Caddy	20-8020-068-01
ROSA TKA Cut Guide Bracket	20-8020-068-02
Universal Validation Tool Assembly Bracket	20-8020-068-03
Condyles Digitizer Bracket	20-8020-068-04

3.3.3 Instrumentation (cont.)

ROSA Knee Instruments

All reusable instruments need to be sterilized before each use.

Component's Name	Part Number
Size 3 Polyaxial Reference Modular Case Bracket	20-8020-068-05
Size 6 Polyaxial Reference Modular Case Bracket,	20-8020-068-06
60mm Pin Stabilizer Modular Case Bracket	20-8020-068-07
60mm Stabilizer Tissue Deflector Modular Case Bracket	20-8020-068-08
Generic Full 5" Base Assembly	00-5888-003-50
Blue Universal Case Lid	00-5967-018-00

Disposables

Component's Name	Part Number
Disposables for Bone References Installation	
Fix Fluted Pin 3.2x150 mm (non-sterile)	20-8000-000-01
Fix Fluted Pin 3.2x80 mm (non-sterile)	20-8000-000-02
Fix Fluted Pin 3.2x150 mm	20-8000-000-10
Fix Fluted Pin 3.2x80 mm	20-8000-000-11
Disposables for Pinning Cut Guides (for pinned resections)	
Trocar Tipped Drill Pin (2.5 mm hex) 3.2x75 mm (Persona)	00-5901-020-00
CAS 3.2 mm Headless Trocar Drill Pin (non-sterile)	20-8000-000-16
Vanguard Quick Release Trocar Pin	32-486255
Vanguard Sterile Quick Release Drill Pin	32-486265
Disposables Checkpoint Screws	
ROSA Checkpoint Screw 13 mm, Non-Sterile	20-8020-194-00
ROSA Checkpoint Screw 13 mm, Sterile	20-8020-158-00
Other Disposables	
Navitracker Kit A: Knee	20-8000-000-07
ROSA Robotic Unit Drape	20-8020-080-00
ROSA Arm Drape	ROSAS00055
Monitor Drape	ROSAS00056
Zimmer Oscillating Saw Blade 1.27 mm	25090127XG1*
Zimmer Oscillating Saw Blade 1.37 mm	25090137XG1*

* If necessary, other hub styles are available.

Handle instruments with care. Avoid dropping instruments. Damage to an instrument can have a significant effect on the accuracy of the procedure and consequently, on the post-operative surgical outcome. At the end of the procedure, instruments are placed in their tray for sterilization. Be aware of the contamination and potential consequent infection risk associated with the complexity of instruments and robotic components (overall geometry, features, sharp edges). Failure to follow the cleaning and sterilization instructions may result in contamination leading to patient infection and organ failure or dysfunction.



3.3.3 Instrumentation (cont.)

3.3.3.1 ROSA Arm Instrument Interface

The ROSA Arm Instrument Interface is attached to the Robotic Arm in sterile conditions using three captive screws. It enables maintaining sterile conditions when changing tools.



This part must be sterilized before each use. Be aware of the contamination and potential consequent infection risk associated with the complexity of instruments and robotic components (overall geometry, features, sharp edges). Failure to follow the cleaning and sterilization instructions may result in contamination leading to patient infection and organ failure or dysfunction.



To avoid touching the non-sterile part of the Robotic Unit and to preserve sterility, always use the handles to hold the ROSA Arm Instrument Interface in place during installation. Be aware of the contamination and potential consequent infection risk associated with the complexity of instruments and robotic components (overall geometry, features, sharp edges). Failure to follow the cleaning and sterilization instructions may result in contamination leading to patient infection and organ failure or dysfunction.

3.3.3.2 ROSA Arm Reference Frame

The ROSA Arm Reference Frame is attached to the Robotic Arm interface with two captive screws. It is used during Robotic Unit registration prior to the start of the surgery.

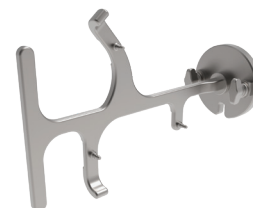

This part must be sterilized before each use. Be aware of the contamination and potential consequent infection risk associated with the complexity of instruments and robotic components (overall geometry, features, sharp edges). Failure to follow the cleaning and sterilization instructions may result in contamination leading to patient infection and organ failure or dysfunction.

3.3.3.3 ROSA Base Reference Frame

The ROSA Base Reference Frame is installed to the Robotic Unit over the ROSA Base Reference Bar, which is covered by a surgical drape using the post closest to the surgical table. It is a reference to follow the relative motions between the Robotic Unit and the Optical Camera.



This part must be sterilized before each use. Be aware of the contamination and potential consequent infection risk associated with the complexity of instruments and robotic components (overall geometry, features, sharp edges). Failure to follow the cleaning and sterilization instructions may result in contamination leading to patient infection and organ failure or dysfunction.



If the ROSA Base Reference Frame moves at any time during the procedure, the registration of the Robotic Arm has to be performed again (SETUP panel).

3.3.3.4 ROSA TKA Cut Guide

The ROSA TKA Cut Guide is attached to the ROSA Arm Instrument Interface with two captive screws. For each implant brand (Persona, NexGen, Vanguard), there are two versions of the ROSA TKA Cut Guide:



- A: When the Robotic Unit and the surgeon are on the left side of the patient regardless of the operated knee
- B: When the Robotic Unit and the surgeon are on the right side of the patient regardless of the operated knee

3.3.3 Instrumentation (cont.)

3.3.3.4 ROSA TKA Cut Guide

 This part must be sterilized before each use. Be aware of the contamination and potential consequent infection risk associated with the complexity of instruments and robotic components (overall geometry, features, sharp edges). Failure to follow the cleaning and sterilization instructions may result in contamination leading to patient infection and organ failure or dysfunction.

3.3.3.5 ROSA Registration Pointer

The ROSA Registration Pointer enables digitizing anatomical landmarks on which final results and accuracy depend.



 This part must be sterilized before each use. Be aware of the contamination and potential consequent infection risk associated with the complexity of instruments and robotic components (overall geometry, features, sharp edges). Failure to follow the cleaning and sterilization instructions may result in contamination leading to patient infection and organ failure or dysfunction.

 Care must be taken not to pierce through the cartilage with the ROSA Registration Pointer tip.

3.3.3.6 Universal Validation Tool Body

The Universal Validation Tool Body is used to validate the femoral distal resection.



 This part must be sterilized before each use. Be aware of the contamination and potential consequent infection risk associated with the complexity of instruments and robotic components (overall geometry, features, sharp edges). Failure to follow the cleaning and sterilization instructions may result in contamination leading to patient infection and organ failure or dysfunction.

 Verify that the Navitracker device is installed on the correct side of the Universal Validation Tool Body.

3.3.3.7 Distal & Posterior Condyles Digitizer

When assembled with the Universal Validation Tool Body, the Distal & Posterior Condyles Digitizer is used to digitize the posterior condylar axis (PCA) and validate the tibial proximal resection.





 This part must be sterilized before each use. Be aware of the contamination and potential consequent infection risk associated with the complexity of instruments and robotic components (overall geometry, features, sharp edges). Failure to follow the cleaning and sterilization instructions may result in contamination leading to patient infection and organ failure or dysfunction.

3.3.3.8 ROSA Knee Condyle Digitizer Small/Medium/Large

When assembled with the Universal Validation Tool Body, the ROSA Knee Condyle Digitizer is used to digitize the posterior condylar axis (PCA). There are three sizes of Condyle Digitizer: Small, Medium, and Large. Size should be selected according to patient anatomy and surgeon preference.



 The appropriate size will allow for the palpators to be in contact with the most prominent aspect of both posterior condyles.

 These instruments must be sterilized before each use. Be aware of the contamination and potential consequent infection risk associated with the complexity of instruments and robotic components (overall geometry, features, sharp edges). Failure to follow the cleaning and sterilization instructions may result in contamination leading to patient infection and organ failure or dysfunction.

3.3.3.8 ROSA Knee Condyle Digitizer Small/Medium/Large (cont.)

The ROSA Knee Condyle Digitizer, Medium (20-8020-191-00) is the same size as the Distal & Posterior Condyles Digitizer (20-8000-010-17)

3.3.3.9 ROSA Knee Tibia Validation Tool

When assembled with the Universal Validation Tool Body, the ROSA Knee Tibia Validation Tool is used to validate the tibial resection.



 This part must be sterilized before each use. Be aware of the contamination and potential consequent infection risk associated with the complexity of instruments and robotic components (overall geometry, features, sharp edges). Failure to follow the cleaning and sterilization instructions may result in contamination leading to patient infection and organ failure or dysfunction.

3.3.3.10 Bone References

3.3.3.10.1 Femoral Reference Frame

3.3.3.10.1.1 2 Pins Reference Femur TS3 P/N: 20-8000-010-33

The Femoral Reference is a bone reference used to track the location of the femur throughout the surgical procedure. The reference is fixed outside the incision, using percutaneous pins through the vastus medialis in the femur, as proximal as possible, to stay clear of the working area. Alternatively, the Femoral Reference can be installed within the incision. The pins should be set near-bicortically (outside incision pin placement) or bicortically (inside incision pin placement) in the bone to ensure maximum stability.

 This part must be sterilized before each use. Be aware of the contamination and potential consequent infection risk associated with the complexity of instruments and robotic components (overall geometry, features, sharp edges). Failure to follow the cleaning and sterilization instructions may result in contamination leading to patient infection and organ failure or dysfunction.



Femoral Reference

2 Pins Reference Femur TS3

3.3.3.10.1.2 ROSA Polyaxial Reference Size 3 (Femur) P/N: 20-8020-037-00

The Polyaxial Reference Size 3 is a bone reference used to track the location of the femur throughout the surgical procedure. It is fixed to the femur, either outside or inside the incision using percutaneous pins. The pins should be set near-bicortically (for outside incision pin placement) or bicortically (for inside incision pin placement) in the femur to ensure maximum stability. When fixed outside the incision, use of the ROSA Pin Stabilizer (see Section 3.3.3.10.1.3.1) is mandatory. The polyaxial mechanisms allow the Optical Tracker to be oriented per surgeon preference to optimize the visibility of the tracker. It is mandatory to tighten these mechanisms with a screwdriver after the desired orientation has been set.



 Verify the knobs of the Polyaxial References are firmly tightened with the Screwdriver and DO NOT loosen at any point during surgery. If a bone reference has moved, the landmarks digitized on that bone must be digitized again.

3.3.3.10.1.2 ROSA Polyaxial Reference Size 3 (Femur) P/N: 20-8020-037-00

 This part must be sterilized before each use. Be aware of the contamination and potential consequent infection risk associated with the complexity of instruments and robot components (overall geometry, features, sharp edges). Failure to follow the cleaning and sterilization instructions may result in contamination leading to patient infection and organ failure or dysfunction.

 Use of the ROSA Pin Stabilizer is mandatory when the ROSA Polyaxial Reference Size 3 (femur) is fixed outside incision.

3.3.3.10.1.3 Femoral Reference Accessories

3.3.3.10.1.3.1 ROSA Pin Stabilizer, 60 mm P/N: 20-8020-039-00

The ROSA Pin Stabilizer is used to stabilize the percutaneous pins in the femur, when a Femoral Reference is fixed outside the incision. The ROSA Pin Stabilizer is inserted through the patient's vastus medialis and improves the Femoral Reference assembly stability.



 This part must be sterilized before each use. Be aware of the contamination and potential consequent infection risk associated with the complexity of instruments and robot components (overall geometry, features, sharp edges). Failure to follow the cleaning and sterilization instructions may result in contamination leading to patient infection and organ failure or dysfunction.

 Do not remove the ROSA Pin Stabilizer from the pins. Its use is mandatory throughout the entire surgery when the ROSA Polyaxial Size 3 (femur) is fixed outside the incision.

3.3.3.10.1.3.2 ROSA Stabilizer Tissue Deflector, 60mm P/N: 20-8020-040-00

The ROSA Stabilizer Tissue Deflector is used with the Pin Stabilizer to facilitate its insertion through the anterior thigh soft tissue. The ROSA Stabilizer Tissue Deflector is placed inside the ROSA Pin Stabilizer to deflect tissue during installation of the ROSA Pin Stabilizer. The ROSA Stabilizer Tissue Deflectors are removed after Pin Stabilizer installation and are not used during the remainder of the surgery.



 This part must be sterilized before each use. Be aware of the contamination and potential consequent infection risk associated with the complexity of instruments and robot components (overall geometry, features, sharp edges). Failure to follow the cleaning and sterilization instructions may result in contamination leading to patient infection and organ failure or dysfunction.



ROSA Stabilizer Tissue Deflectors Inside ROSA Pin Stabilizer

3.3.3.10.2 Tibia References

3.3.3.10.2.1 ROSA Tibia Reference A/B P/N: 20-8020-028-00/20-8020-029-00

The Tibial Reference is a bone reference used to track the location of the tibia throughout the surgical procedure. It is fixed outside the incision, using percutaneous pins normal to the medial surface of the tibial diaphysis at approximately four fingers distal to the knee incision. Alternatively, the Tibial Reference can also be installed inside the incision. The pins should be set near-bicortically (outside incision pin placement) or bicortically (inside incision pin placement) in the bone to ensure maximum stability.

 This part must be sterilized before each use. Be aware of the contamination and potential consequent infection risk associated with the complexity of instruments and robotic components (overall geometry, features, sharp edges). Failure to follow the cleaning and sterilization instructions may result in contamination leading to patient infection and organ failure or dysfunction.



Tibial Reference B



Tibial Reference A





OR Setup

- A: When the Robotic Unit is on the left side of the patient regardless of the operated knee
- B: When the Robotic Unit is on the right side of the patient regardless of the operated knee

Insert pins through the pin holes marked L or R. For right legs, use pin holes labeled R, for left legs, use pin holes labeled L. Use the appropriate set screws corresponding to the pinholes through which the pins have been inserted to tighten the reference on pins.

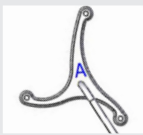
 Use the left (L) or right (R) pin holes based on the operated leg.

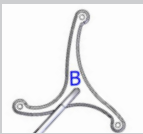
Insert pins through the appropriately marked holes according to the table below.

	Right Leg Operated	Left Leg Operated
Tibial Reference A 	Pins through R marking 	Pins through L marking 
Tibial Reference B 	Pins through R marking 	Pins through L marking 

3.3.3.10.2.2 ROSA Polyaxial Reference Size 6 (Tibia) P/N: 20-8020-038-00

The Polyaxial Reference Size 6 is a bone reference used to track the location of the tibia throughout the surgical procedure. It is fixed either outside or inside the incision using percutaneous pins. The pins should be set near-bicortically (outside incision pin placement) or bicortically (inside incision pin placement) in the tibia to ensure maximum stability. The polyaxial mechanisms allow the Optical Tracker to be oriented per surgeon preference to optimize the visibility of the tracker. It is mandatory to tighten these mechanisms with a screwdriver after the desired orientation has been set.

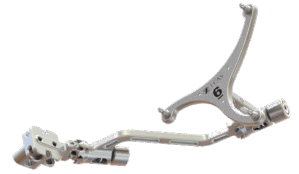

This part must be sterilized before each use. Be aware of the contamination and potential consequent infection risk associated with the complexity of instruments and robot components (overall geometry, features, sharp edges). Failure to follow the cleaning and sterilization instructions may result in contamination leading to patient infection and organ failure or dysfunction.



3.3.3.10.2.3 Offset 2 Pins Reference Tibia P/N: 20-8000-010-35/20-8000-010-36

The Tibial Reference on the patient's tibia is used to track the location of the tibia throughout the surgical procedure. It is fixed using percutaneous pins into the medial surface of the tibial diaphysis at approximately mid-tibia. For outside incision, the pins should be set near-bicortically in the bone to ensure maximum stability.



Only for Placement Outside the Incision

This part must be sterilized before each use. Be aware of the contamination and potential consequent infection risk associated with the complexity of instruments and robotic components (overall geometry, features, sharp edges).



Failure to follow the cleaning and sterilization instructions may result in contamination leading to patient infection and organ failure or dysfunction.



Tibial Reference RT

Offset 2 Pins Reference Right Tibia Size 6



Tibial Reference LT

Offset 2 Pins Reference Left Tibia Size 6

There is a RIGHT and a LEFT Offset 2 Pins Reference Tibia. OR setup determines whether to use RIGHT or LEFT:

- LEFT: When the Robotic Unit is on the left side of the patient, regardless of the operated knee
- RIGHT: When the Robotic Unit is on the right side of the patient, regardless of the operated knee

Before every surgery, the user must verify that all instruments have been sterilized. Be aware of the











contamination and potential consequent infection risk associated with the complexity of instruments and robotic components (overall geometry, features, sharp edges). Failure to follow the cleaning and sterilization instructions may result in contamination leading to patient infection and organ failure or dysfunction.

For reusable instruments, also refer to the instrument's package insert and Reusable Instrument Lifespan



Manual. Be aware of the contamination and potential consequent infection risk associated with the complexity of instruments and robotic components (overall geometry, features, sharp edges). Failure to follow the cleaning and sterilization instructions may result in contamination leading to patient infection and organ failure or dysfunction.

3.3.3.10.2.3 Offset 2 Pins Reference Tibia P/N: 20-8000-010-35/20-8000-010-36 (cont.)

-  Verify the integrity of all the instruments prior to each surgery. Visually inspect the instruments for damages such as cracks, burrs, sharp edges, deformation or a loose weld. For reusable instruments, also refer to the instrument's package insert and Reusable Instrument Lifespan Manual.
-  Make sure that the pins are not positioned close to the bone resection area. Placing the pins close to the bone resection area will increase the risk of breaking the pins with the cutting tools. Pin breakage could result in bone removal or non-functioning joint.
-  Verify the proper fixation of the percutaneous pins in the patient's bone anatomy (femur and tibia).
-  Verify the proper fixation of the bone references on the pins (femur and tibia). The femur and tibia references are secured on the pins, close to the patient's skin (without compression), using two hexagonal screws.
-  Bone references **MUST** be firmly attached to the bone and **MUST NOT** move at any moment during surgery. If a bone reference has moved, the landmarks digitized on that bone must be digitized again.
-  Be alert to the risk of causing damage to neurovascular structures, including femoral artery and vein or the popliteal artery and vein while installing the femoral bone reference.
-  Ensure that the pins are not placed in an area of interference with the tibial implant stem. Impact with the stem or broaching instruments can cause breakage of the pins as well as movement of the reference, which could result in inaccuracies. Pin breakage may result in bone removal or non-functioning joint.
-  Beware that muscle fibers may apply bending forces on the pins.

3.4 Instrumentation Assembly

The following instructions explain how to assemble ROSA Knee instruments.

- ⚠ Always verify the proper installation of an instrument to the Robotic Unit or Robotic Arm by making sure all screws are firmly tightened.

3.4.1 ROSA Arm Instrument Interface on the Robotic Arm

1. Align the groove on the back of the ROSA Arm Instrument Interface (laser marked arrow on the side) with the peg of the electric insulator of the Robotic Arm (black dashed line).
2. Assemble instruments together until the base of the ROSA Arm Instrument Interface is completely seated.
3. Secure the ROSA Arm Instrument Interface by firmly tightening the three captive screws using a hexagonal screwdriver.

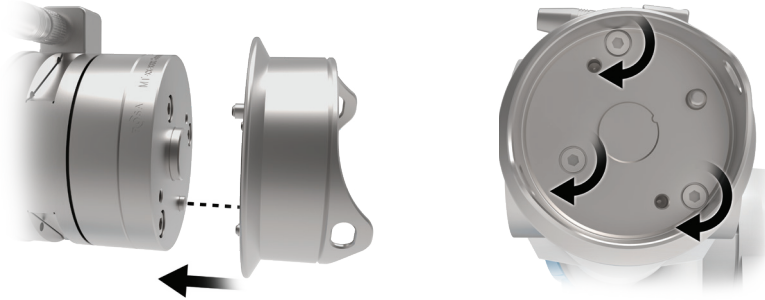

To avoid touching the non-sterile part of the Robotic Unit and to preserve sterility, always use the handles to hold the ROSA Arm Instrument Interface in place during installation. Be aware of the contamination and

- ⚠ potential consequent infection risk associated with the complexity of instruments and robotic components (overall geometry, features, sharp edges). Failure to follow the cleaning and sterilization instructions may result in contamination leading to patient infection and organ failure or dysfunction.

- ⚠ Do not apply excessive torque on screws when installing an instrument. Do not use power tools.

- ⚠ Be careful with the alignment of screws in their thread.

3.4.2 ROSA Arm Reference Frame on the Robotic Arm

1. Align the groove of the ROSA Arm Reference Frame with the peg of the ROSA Arm Instrument Interface (black dashed line).
2. Assemble instruments together until the base of the ROSA Arm Reference Frame is completely seated.
3. Secure the ROSA Arm Reference Frame by firmly tightening the two captive screws by hand.

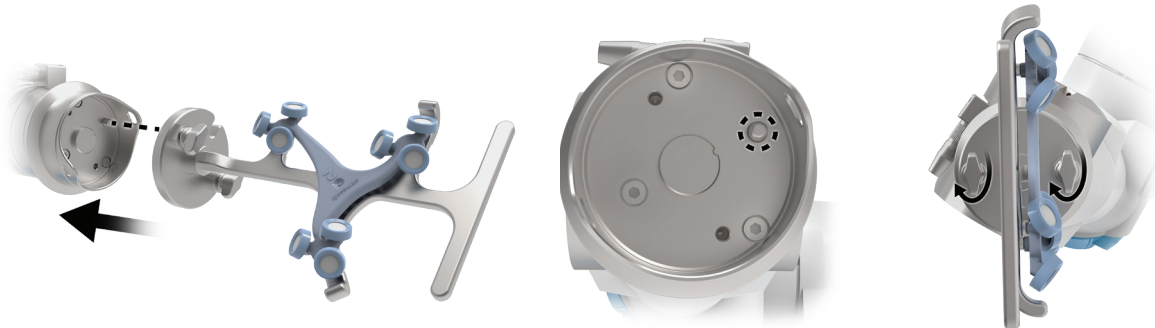

3.4.3 ROSA Base Reference Frame on the Robotic Unit

1. Open the clamp of the ROSA Base Reference Frame and align it on the post closest to the surgical table.
2. Assemble instruments together until the ROSA Base Reference Frame is completely seated vertically.
3. Close the clamp and bring the hand screw over the clamp.
4. Secure the ROSA Base Reference Frame by firmly tightening the screw by hand.
 - Instructions apply both for short and long ROSA Base Reference Frames



3.4.4 ROSA TKA Cut Guide on the Robotic Arm

1. Align the groove of the ROSA TKA Cut Guide with the peg of the ROSA Arm Instrument Interface (black dashed line).
2. Assemble instruments together until the base of the ROSA TKA Cut Guide is completely seated.
3. Secure ROSA TKA Cut Guide by firmly tightening the two captive screws by hand.

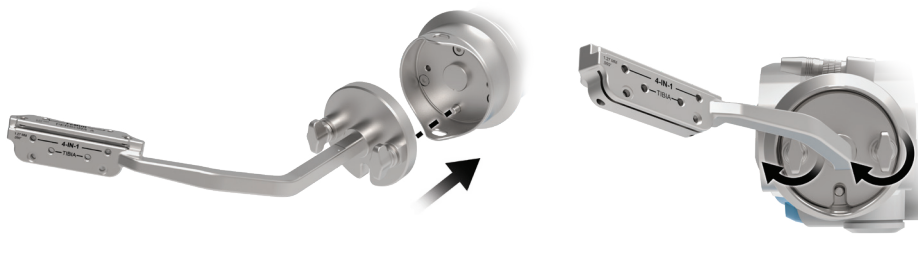

 Do not apply excessive torque on screws when installing an instrument. Do not use power tools.

3.4.5 Universal Validation Tool Body and ROSA Knee Tibia Validation Tool (or Distal & Posterior Condyles Digitizer)

Tibial Proximal Resection Validation

- These two instruments need to be assembled together for the validation of the tibial proximal resection
- Make sure both instruments are locked together using the lever

For the validation of the tibial proximal resection, make sure the

- ! Universal Validation Tool Body and ROSA Knee Tibia Validation Tool (or Distal & Posterior Condyle Digitizer) are locked together using the lever.

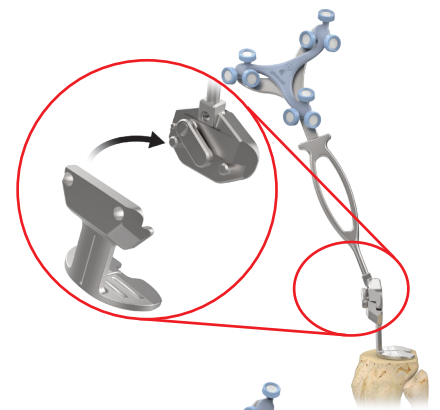

Femoral Distal Resection Validation

- Only the Universal Validation Tool Body is used for the validation of the femoral distal resection
- Make sure to disconnect the Distal & Posterior Condyles Digitizer, ROSA Knee Condyle Digitizers or ROSA Knee Tibia Validation Tool from the Universal Validation Tool Body

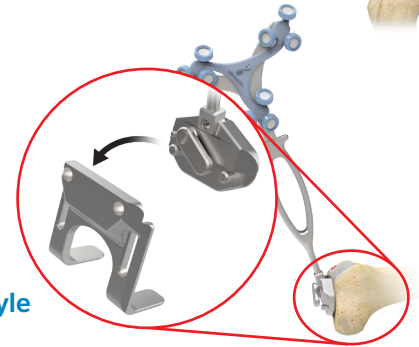

3.4.6 Universal Validation Tool Body and Condyle Digitizers (ROSA Knee Condyle Digitizer/Distal & Posterior Condyles Digitizer)

Posterior Condyle Digitization

- The Universal Validation Tool Body and one of the three available sizes (Small/Medium/Large) of the ROSA Knee Condyle Digitizer (or Distal & Posterior Condyles Digitizer) need to be assembled together for the digitization of the posterior condyles of the femur
- Make sure both instruments are locked together using the lever

For the digitization of the posterior condyles of the femur, make sure the

- ! Universal Validation Tool Body and ROSA Knee Condyle Digitizer (or Distal & Posterior Condyles Digitizer) are locked together using the lever.

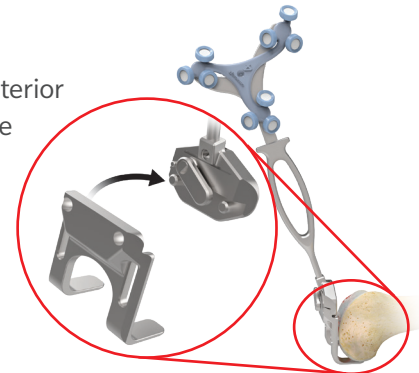

3.5 Disposables

- ! Ensure the packaging integrity (shelf box, outer package, inner package and foil pouch) and shelf life date and sterility indicator. Failure to do so may result in contamination leading to organ failure or dysfunction.

3.5.1 Reflective Trackers (NavitrackER) Installation

The NavitrackER devices must be installed on each instrument used for optical tracking. To facilitate the installation of the trackers on the instruments, push the marker on each mounting stud using the NavitrackER pliers until it is fully seated.

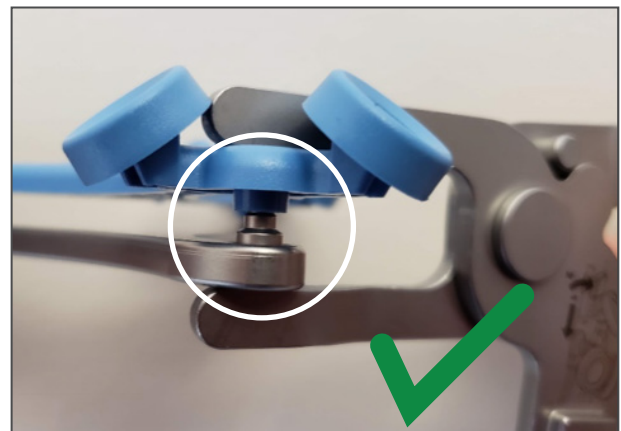
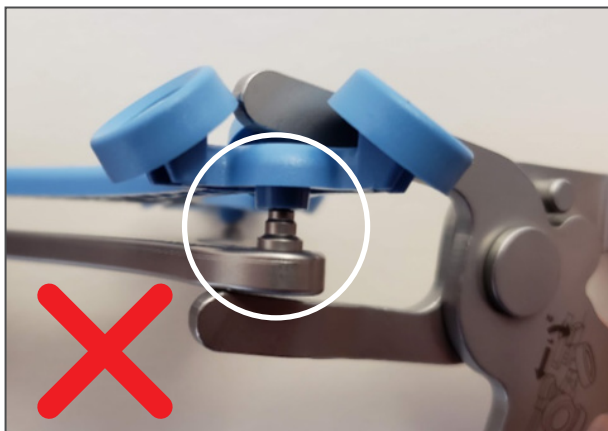

3.5.1 Reflective Trackers (NavitrackER) Installation (cont.)

A click should be heard. It is important to verify that the NavitrackER devices remain clean throughout the surgery (refer to NavitrackER Instructions for Use).

The Universal Validation Tool Body is laser marked either RIGHT or LEFT.

Installation of NavitrackER on the Correct Side of the Universal Validation Tool Body:

- LEFT Side: When the Robotic Unit is on the left side of the patient, regardless of the operated knee
- RIGHT Side: When the Robotic Unit is on the right side of the patient, regardless of the operated knee

 Always use NavitrackER pliers for the installation. Ensure that reflective NavitrackER devices are fully seated.

 Verify the proper fixation of the NavitrackER devices on each instrument (ROSA Base & Arm Reference Frame, ROSA Registration Pointer, Bone References and Universal Validation Tool Body). Always use the NavitrackER pliers for installation.

 Always minimize handling of the NavitrackER devices, since errors may result from the non-uniform reflection of their surface.

 Always use unblemished trackers.

 Each NavitrackER device is single use and must not be resterilized to be reused in surgery.

The NavitrackER devices must be installed on all used instruments for optical tracking using the NavitrackER pliers. Push the marker onto the mounting studs until it is fully seated. It is important to verify that the NavitrackER devices remain clean throughout the surgery.

 Do not use any Optical Trackers other than those provided by Zimmer Biomet.

#2 ROSA Arm Reference Frame



#6 Tibia Bone Reference



#3 Femur Bone Reference

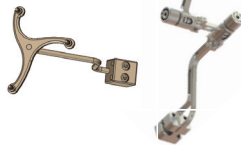

#7 ROSA Registration Pointer



#4 Universal Validation Tool Body



#9 ROSA Base Reference Frame



3.5.2 Pins

Fix fluted pins (sterile and non-sterile) can be used to fix the bone references. The diameter is 3.2 mm and has a length of 80 mm or 150 mm. Refer to section 3.3.3. for pins for the Cut Guides (for pinned resections).



Pins are single-use hardware and must not be resterilized to be reused in surgery.

3.5.3 ROSA Checkpoint Screws

The ROSA Checkpoint Screws can be installed in the femur and tibia to verify stability of the Bone References throughout the surgery.



ROSA Checkpoints Screws are single-use hardware and must not be resterilized to be reused in surgery.

3.5.4 Drapes

Drapes for the Robotic Unit and Touchscreens are required prior to starting the surgery.



Never use a torn drape (Robotic Arm or base). In case of a tear or in doubt that the sterility is compromised, discard the drape and use a new one. Failure to do so may result in contamination leading to potential patient infection and organ failure or dysfunction.



Never use damaged tape for taping the ROSA Arm Drape to the ROSA Arm Instrument Interface at the end of the Robotic Arm. Failure to do so may result in contamination leading to potential patient infection and organ failure or dysfunction.

4. Installation

4.1 Warnings and Cautions About Robotic Unit Installation

 Ensure that the Robotic Unit is not moved once the immobilization system is locked.

Risks of pinching:

-  Do not place fingers in accessible parts of the plastic covers of the Robotic Arm
- Do not place fingers or feet under the stabilization feet before immobilization of the system

 In order to avoid any risk of electric shock, the device must only be connected to an electric power network equipped with grounding. Device is class I, type BF.

 Do not simultaneously touch the patient and any component of the device other than those attached to the electrical isolation interface part.

 Ensure that the Foot Pedal is operating correctly before beginning a procedure. Visually inspect the device and perform a test for interruption/resumption of Robotic Arm movement.

 The operating table must not be moved once an instrument guided by the Robotic Unit is inserted into the patient anatomy.

Risks generated by laser beam exposure: the device uses a laser integrated into the Optical Camera.

 This laser is of class 2 (power inferior to 1 mW, eye protection by the palpebral reflex). Do not orient the laser beam to the eyes or to any light-reflecting surfaces (such as mirrors) to avoid any direct or indirect exposure to laser beam.

 Verify the position of the device and its environment when using the Robotic Unit immobilization system.

 During transportation, the device can be immobilized by activating the immobilization pedal. Do not install the device on an inclined surface, unless its stability is guaranteed.

 IPX0 Protection: Device without special protection against the penetration of liquids. Do not pour any liquids over the device.

 Do not connect any elements to the Robotic Unit other than those provided with the device.

4.2 Device Start Up

Switching the device ON:

1. Place the Robotic Unit on one side of the operating table and the Optical Unit on the opposite side. Plug the Optical Unit into the Robotic Unit.
 - For Configuration 1 Only: Plug the white and black cables into the corresponding white and black ports
 - For Configuration 2 Only: Plug the USB, Ethernet, Jack and VGA cables into the corresponding ports
 - For Configuration 3 Only: Plug the single connector into its socket and secure the connection
2. Plug the Power Supply Cable into a power source of appropriate voltage.
3. For Configuration 1 and 2 Only: Attach the metallic ring of the Optical Unit Cable to the hook on the Robotic Unit Rear Panel. Lock the connector in place using the metallic clip.
4. Switch the robot ON.
 - Allow the camera to warm up for few minutes

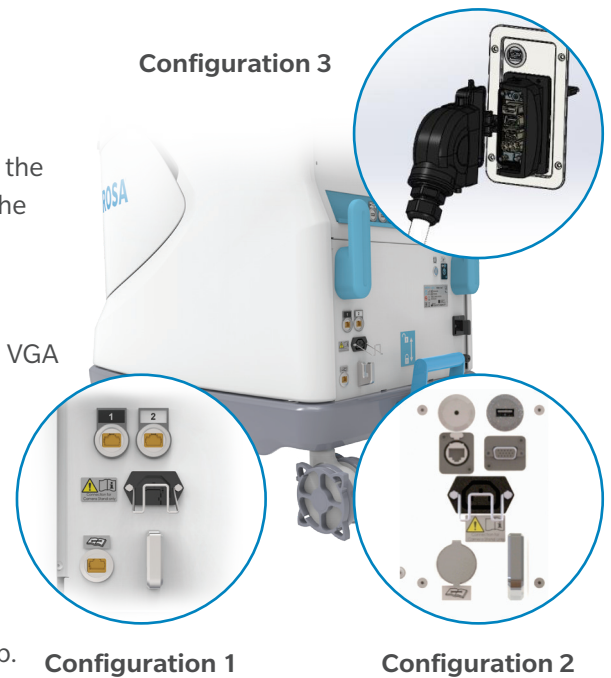

Refer to previous figure for connection identification.



In order to prevent accidental detachment of connectors, ensure the metallic ring is attached to the Robotic Unit's hook and lock the connector in place using the metallic clip, if applicable.



Make sure the metallic ring of the Optical Unit Cable is attached to the hook on the Rear Panel of the Robotic Unit in order to ensure EMC protection, if applicable.



If the screen remains black at start up: Check that the Touchscreen is powered ON (button on the right side of the screen) and/or restart the computer by pushing the button located on the Rear Panel of the device.



To restart the device, wait at least 10 seconds after shutting down and for the RESTART button light to turn off before powering back on.



The device may take up to three minutes after being switched ON for the application to communicate with the Robotic Arm.

4.3 Camera Errors

4.3.1 Camera Temperature is Too Low/High

When launching the application, if the camera temperature is out of range, a notification will be displayed.

1. Wait for the camera to adjust to room temperature.
2. Click RESUME to continue.

4.4 Emergency Procedure

In case of device failure or an emergency requiring a fast removal of the device to access the patient, it is recommended to follow one of the procedures described below. The user may choose to move the device away from the operating table partially or completely, depending on the procedure that is needed to cope with the device failure or emergency.

Partial Removal–Moving the Robotic Arm Away

1. Remove any instruments that are linking the patient to the Robotic Unit.
2. Send the Robotic Arm to the ROSA HOME position to free space around the patient's knee.

This procedure can be performed by one sterile operator.

Full Removal–Moving the Robotic Unit Away

1. Remove any instruments that are linking the patient to the Robotic Unit.
2. Deactivate the Robotic Unit immobilization system (one main pedal and four wheels).
3. Move the Robotic Unit away to free up space around the patient.
4. If necessary, move the Optical Unit away after releasing the wheels' brakes.
5. If necessary, remove the patient's bone references (femur and tibia).
6. After a full removal of the Robotic Unit, revert to standard instrumentation.



This procedure requires one sterile operator and one non-sterile operator. Sterile user shall avoid any contact with non-sterile surfaces of the Robotic Unit and Optical Unit. Failure to follow instruction for full removal of the Robotic Unit may result in contamination leading to patient infection and organ failure or dysfunction.



If there was a full removal of the Robotic Unit, if bone references were removed or if there was a problem with ROSA Knee instrumentation that could lead to inaccuracy, the surgeon must revert back to standard instrumentation.

Any serious incident related to the device should be reported to the manufacturer and the competent authority of the Member State by the user and/or patient.

4.5 Reverting to Standard Instrumentation

A full set of the implant system's standard instrumentation is needed to perform a surgery in conjunction with the ROSA Knee System in case the ROSA Knee System cannot be used. It is mandatory to revert to standard instrumentation in case of:

- Full removal of the Robotic Unit
- Problem with the ROSA Knee instrumentation that could lead to inaccuracy

For any other problem encountered at any time during the surgical flow, it is always possible to revert to standard instrumentation. For example, if the pin/drill holes were already performed with the ROSA TKA Cut Guides, these holes can be reused with their respective standard Cut Guide counterpart (e.g. ROSA Persona TKA Cut Guide A (20-8020-007-00) can be reused with a standard Persona 0 Degree Distal Femoral Cut Guide (42-5099-010-00)).

4.6 Case Management Application

4.6.1 Case Management Application–Interface Overview



Case Management Application Functions

SYNC: This function decrypts the case(s) from a USB drive and syncs them with the ROSA Clinical Computer.

CASES: This function lists the cases that were uploaded using the SYNC function. When selecting a case, a PIN will be required to load the case and launch the welcome screen of the ROSA Surgery application.

LOGOUT: This function exits the case management application and should only be used by authorized personnel to access the Maintenance mode.

SHUTDOWN: This function shuts down the system.

EXPORT REPORTS: This function encrypts and exports all pending ROSA Reports to USB drive.

ROSA INFORMATION: A panel that shows you what versions of applications are installed on your system.

EDUCATION: A media interface containing useful information, including educational videos, on your device.

FLIGHT SIMULATOR: A standalone software feature launched from the Case Management Application for demonstration and supplemental educational purposes only. It does not control the Robotic Arm or the tracking system, and it is not intended for clinical use. It is not a substitute for formal user training on the medical device.

Wi-Fi BUTTON: Allows access to the ROSA Connectivity Application for authorized users. Refer to 4147-GLBL-en ROSA Connectivity - Connectivity Features of the ROSA Recon Platform for more information.

4.6 Case Management Application (cont.)

4.6.2 Starting a Case

The case management application will start upon powering up the system.

1. Insert a USB drive containing the encrypted case(s) in a USB port.
2. Use the SYNC function to upload the case(s) to the ROSA Clinical Computer.
3. Use the CASES function to search for the case to be launched (at least three letters).
4. Select the appropriate case and click Launch.
5. Type in the PIN for the selected case.

Note, the same patient case can only be launched a maximum of two times.

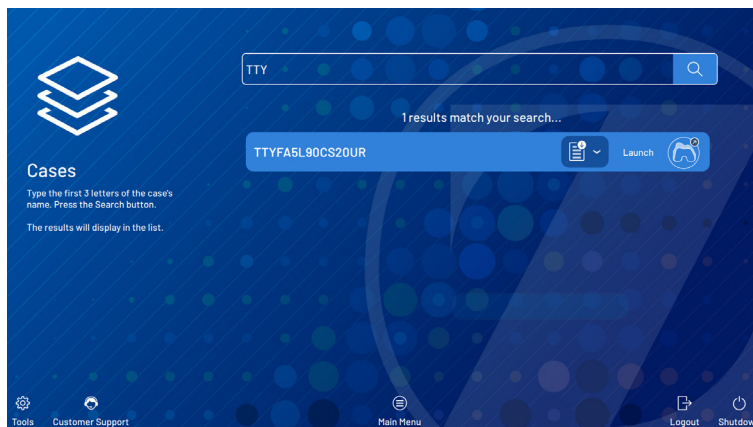

5. Intra-operative Guide/ Surgery

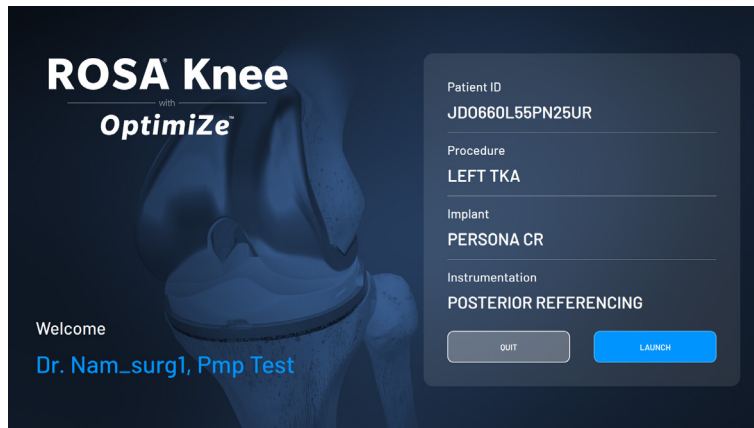

ROSA Knee Application: Welcome Screen

5.1 Welcome Screen

Upon launching a case, a welcome screen will appear where the user can confirm the patient ID, procedure laterality, implant family and instrumentation. Once the user has confirmed that the information is correct, the ROSA Knee application can be launched. If the information is incorrect, the user will need to quit and relaunch the correct case.

5.2 ROSA Knee Application–User Interface Overview



ROSA Knee Application User Interface

The ROSA Knee User Interface consists of a main panel and two task bars on the top and bottom of the screen. The task bars contain features that may be accessible in more than one panel.

5.2.1 Top Task Bar

5.2.1.1 Panel Buttons

The panel buttons allow direct access to a specific panel. An icon featuring a blue background indicates the currently active panel. Icons featuring white outlines indicate that the panel(s) are directly accessible. Greyed out icons indicate that these panels are not yet accessible. Inaccessible panels will become accessible once all necessary preceding tasks have been completed. The number and order of the displayed icons depend on preferences defined in the SURGEON panel.

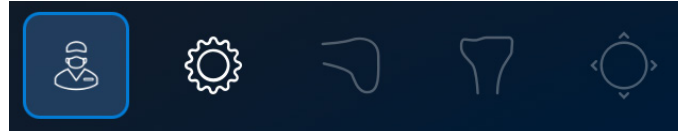

Panel Buttons

Panel	Mandatory	Optional
SURGEON	✓	
SETUP	✓	
FEMUR	✓	
TIBIA	✓	
EVALUATION		✓
PLANNING	✓	
RESECTIONS Panel:		
• Femoral Distal Resection	✓	
• Tibial Proximal Resection	✓	
• Femoral Rotation Tool		✓
• 4-in-1 Resections	✓	

5.2.1.2 Case Information

The case information displays the following details:

- Procedure laterality
- Implant editor (brand, femoral and tibial implant, instrumentation)
- Patient ID



Case Information

5.2.1.2 Case Information (cont.)

Implant component sizes are displayed directly on the user interface. All supported implants are shown in Appendix A. Implant compatibility can be found in Appendices B and C.

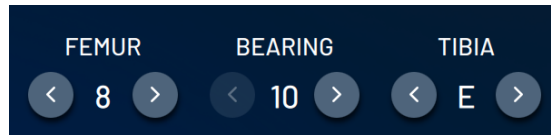

Implant Selector



The implant related information can only be modified in the PLANNING panel and in the implant confirmation window.

5.2.2 Bottom Task Bar



Bottom Task Bar

5.2.2.1 Menu

The MENU button consists of:

- Language: Change User Interface language
- About: Information about the ROSA Knee application
- Customer Support: Customer Service details
- Volume: Adjustment of the volume of all sounds of the ROSA Knee application
- Quit Application: Quit with an option to send the Robotic Arm to PARK position

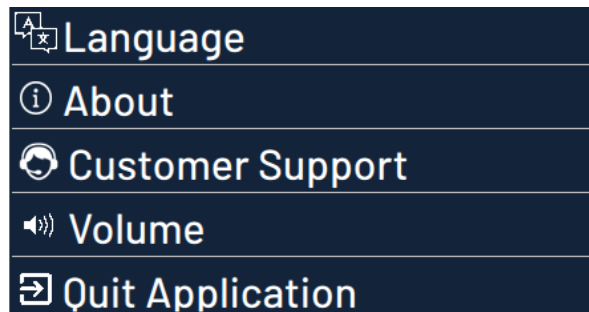

Menu

The MENU button is accessible at all times during the procedure.

5.2.2.2 Camera

The CAMERA button displays the volume viewer, which shows the top view (left side) and frontal view (right side) of the camera volume. By default, only the NavitrackERs that are needed at the current step of the workflow are displayed. The ALL NAVITRACKERS button will display all visible NavitrackERs. The CAMERA button is accessible at all times during the procedure.

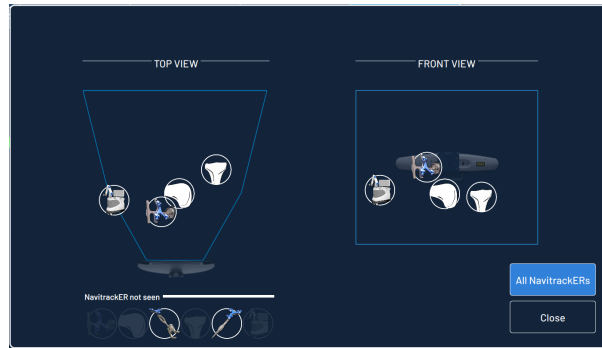

Camera Volume Viewer



The camera can be slightly repositioned at any time in order to have the necessary NavitrackER devices visible, except during registration (six points), acquisition of the femoral head center and in Bone Tracking mode.

During bone resections, the camera needs to stay in a volume close to where the registration was initially performed.

5.2.2.3 Snapshot

The SNAPSHOT button saves a capture of the screen. The SNAPSHOT button is accessible at all times during the procedure. Snapshots can be downloaded along with the Surgeon Report.

5.2.2.4 HKA

The HIP-KNEE-ANKLE (HKA) button displays the pre-operative leg alignment (PREOP), the most recent value of the HKA saved in the EVALUATION panel (EVALUATED) and to the currently planned HKA (PLANNED). The HKA button is accessible at all times during the procedure. The pre-operative HKA is only available for image-based cases.

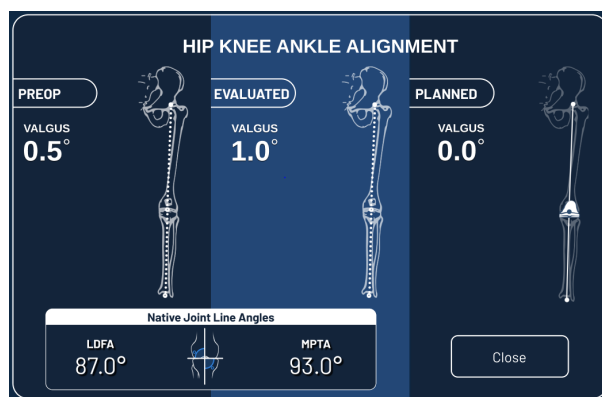

HKA Window

If the Kinematic Alignment option is selected in the SURGEON panel, the Lateral Distal Femoral Angle (LDFA) and the Medial Proximal Tibial Angle (MPTA) are displayed. The LDFA and the MPTA consider the femur and tibia wear evaluation values entered during landmarking.

5.2.2.5 Distal Viewer

The DISTAL VIEWER button displays a representation of the painted surface from the most recent acquisition of the Medial and Lateral Distal Condyle landmarks. The system displays the live navigation of the pointer tip to the most distal points. This allows the surgeon to estimate the femoral wear at the most distal point.

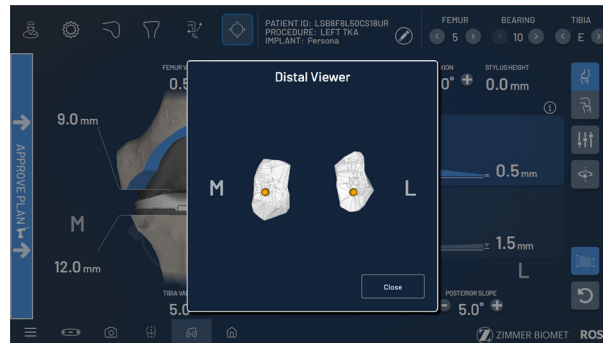

Distal Viewer

5.2.2.6 Bone Reference Checkpoint (optional)

The Bone Reference Checkpoint is an optional feature allowing the surgeon to verify that the Bone References have not moved since landmarking.

ROSA Checkpoint Screws are installed during landmarking and the ROSA Registration Pointer is used to acquire the divot on the femur and tibia Checkpoint Screws.

If the Bone Reference Checkpoint fails, the associated Bone Reference may have moved and accuracy of the system may be affected. The user will be prompted to verify stability of the ROSA Checkpoint Screw, the Bone Reference and the Navitracker, and retake landmarks before resections.

The BONE REFERENCE CHECKPOINT button is accessible at all times during the procedure.

5.3 Robotic Modes

Three robotic modes are programmed to dictate the behavior of the Robotic Arm at two distinct steps: registration (SETUP panel) and bone resections (RESECTIONS panel). To trigger any motion of the robotic arm, the Foot Pedal must be pressed. The interface indicates the current mode with a color border around the main panel.

Automatic Mode (Orange border)

- The Robotic Arm will move to a pre-determined position

Collaborative Mode (Green border)

- The Robotic Arm will move if the surgeon applies a gentle force to the end of the Robotic Arm to move it to a desired position
- The Robotic Arm will move at a slow speed when it nears the bone
- During resections, the Collaborative mode is coupled with bone tracking. If the bone moves as the surgeon is moving the Cut Guide, it will stay on plane and track the bone position. This is Collaborative mode with Bone Tracking
- During resections with Active Track™, the Collaborative mode is coupled with bone tracking and higher movement resistance, limiting unwanted Cut Guide movement. This is Collaborative mode with the assistance of force thresholds to help keep the Cut Guide near the bone while performing the resection

Stationary Mode (Grey border)

- The Robotic Arm will not move

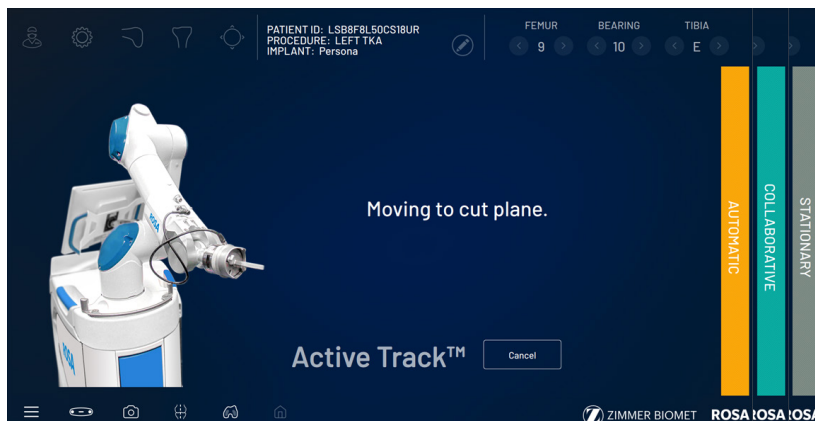

5.4 Robotic Positions

At various points during the ROSA Knee System surgical flow, the Robotic Arm is sent to a defined position:

- HOME position:
 - Goes to this position after successful registration and remains there until resections
 - ROSA Knee TKA Cut Guide is installed in this position
 - Goes to this position when the ROSA HOME button is selected
- PARK position:
 - Position for transportation and storage
 - When the robot is turned on, the Robotic Arm will be in PARK position
 - Upon quitting the application after surgery and after undraping the robot, the Robotic Arm will be sent to PARK position for shut down

5.5 Application Audio Notifications

The application has distinct audio notifications for the following situations:

- Robotic Arm in Automatic mode and moving to a predetermined location
- Robotic Arm in Bone Tracking mode and tracker is hidden or Foot Pedal not pressed
- Successful landmark acquisition
- Major or minor notification
- Snapshot of the current screen
- Painting acquisition

5.6 Application Visual Notifications

Foot Pedal

- Press and hold the Foot Pedal to move the Robotic Arm, acquire Knee State Evaluation or paint medial and lateral distal condyle landmarks
- Further direction on the screen will describe the current action



Continue pressing the Foot Pedal when pinning, resecting with Active Track or drilling in Collaborative mode to enable Bone Tracking mode, otherwise accuracy may be impacted. Visual and audio notifications are provided if the Foot Pedal is released during Collaborative mode with Bone Tracking.



Movement Needed

- During landmarking, a movement is needed to start the acquisition. The movement is needed for:
Femur: Femoral head center acquisition
Instruments: ROSA Registration Pointer and Universal Validation Body Tool

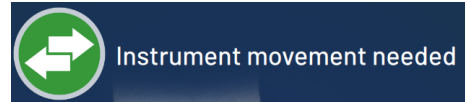
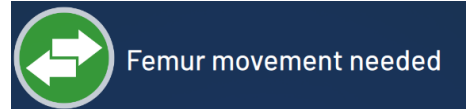

Landmark Acquisition Points

Landmark acquisition will display recommended locations with three colors:

- **White:** Upcoming landmark to be registered
- **Yellow:** Current landmark to be registered
- **Green:** Landmark successfully registered



Point Too Close

- During landmarking, an acquisition point is too close to the previous points and was not recorded. Move away and stabilize again for a successful acquisition or reacquire the painting

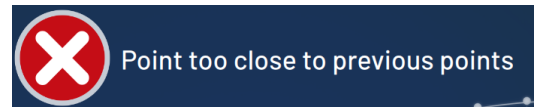

Outside Target Area

- During landmarking of the anterior cortex, an acquisition point was outside the dashed target area displayed on the user interface. Move inside the target area and stabilize again for a successful acquisition
- During painted landmarking of the medial and lateral distal condyles, the ROSA Registration Pointer is outside the target region. Release the Foot Pedal, position the ROSA Registration Pointer on the condyle and continue acquiring the painted surface



5.6 Application Visual Notifications (cont.)

Wrong Laterality

- During landmarking, an acquisition point was taken on the wrong side of the bone (medial vs lateral). Reacquire the point on the correct side

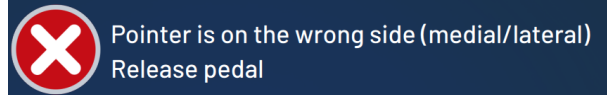

Foot Pedal Release

- During landmarking, if the Foot Pedal is pressed upon entering the Medial or Lateral Distal Condyle landmark acquisition step, the Foot Pedal needs to be released before proceeding with the painting acquisition



Maximum Points Capacity Reached

- During landmarking of the medial and lateral distal condyles, if the application could not produce a valid most distal point and the maximum number of points has been reached. Release the Foot Pedal and restart painting acquisition

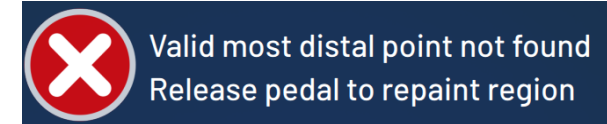

Navitracker Not Seen

- A Navitracker is not visible by the camera. Either something is blocking the view or the camera needs to be readjusted

An icon will be shown for the following:

Instruments: ROSA Registration Pointer
 ROSA Arm Reference Frame
 ROSA Base Reference Frame
 Universal Validation Body Tool

References: Femoral Tracker
 Tibial Tracker

Notification



Instrument Icons



Reference Icons



The camera can be slightly repositioned at any time in order to have the necessary Navitracker devices visible, except during the acquisition of the femoral head center and in bone tracking. During bone resections, the camera needs to stay in a volume close to where the registration was initially performed.

Movement Detected

During resections, a movement of the robot or the camera was detected. Ensure that the camera and the robot remain stable, and that there are no external forces or vibrations applied by nearby equipment.

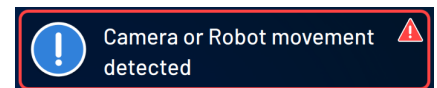
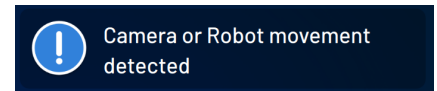

5.6 Application Visual Notifications (cont.)

OptimiZe Planning™ Feature

Visual notifications are displayed in the user interface based on the planning found:

Gap Range Exceeded

A notification icon appears beside each gap value that is outside the selected profile's gap range.



Gap Shape not Respected

A notification icon appears beside the extension and/or flexion icon when the gap shape in extension and/or flexion does not respect the selected profile.



Min & Max Symbols

A notification icon appears beside the resection and angle parameters that have reached the upper or lower limits of the ranges of the selected profile.



5.6 Application Visual Notifications (cont.)

 Any visual notifications related to OptimiZe Planning are removed when the plan is modified.

No Planning Found

When OptimiZe Planning is unable to find a plan, a pop-up window notifies the user that no planning was found:

- A pop-up window appears when the profile criteria cannot be satisfied (e.g. profile's ranges are too tight, etc.)
- A pop-up window appears when OptimiZe Planning has reached the timeout limit. For both notifications, the user must acknowledge that no planning was found by clicking the OK button

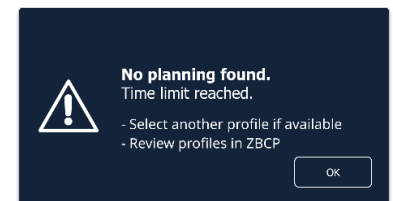
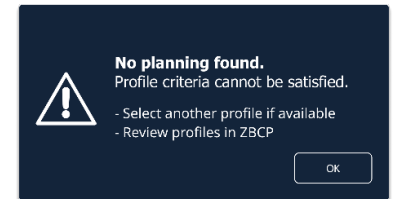

 Any profile triggering a 'No Planning Found' will be disabled in the drop-down menu. The user can launch a different profile or plan manually.

 Parameters in the PLANNING panel influence each other. Review the overall surgical plan before proceeding to the RESECTIONS panel.

5.7 ROSA Knee Application–SURGEON Panel

In the SURGEON panel, the user can select preferences for certain intra-operative parameters. Preferences are classified into the following categories:

- Femoral Rotation Axis Display
- Knee State Evaluation
- Femoral Rotation Tool
- Flexion Angles for Stress Tests
- Bone Reference Checkpoint
- Kinematic Alignment (Persona CR Only)
- Active Track

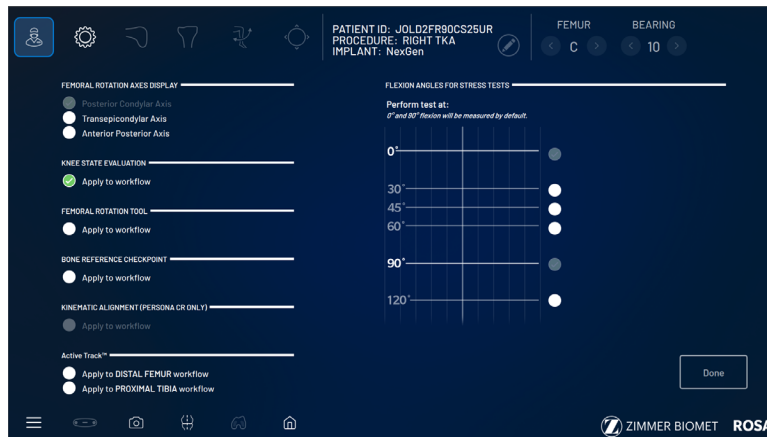

SURGEON Panel

Note, the preferences can be set pre-operatively through ZBCP.

5.7 ROSA Knee Application–SURGEON Panel (cont.)

A green checkmark means the option is selected. Depending on the preferences, different surgical steps will become active (e.g. EVALUATION panel and Femoral Rotation Tool in the RESECTIONS panel).

1. Click DONE when all preferences have been chosen to proceed to the SETUP panel.

5.7.1 Femoral Rotation Axis Display

The ROSA Knee System can display different femoral rotation axes in the PLANNING panel, based on surgeon preferences:

- Posterior Condylar Axis (PCA)
- Transepicondylar Axis (TEA)
- Anterior Posterior Axis (AP)

By default, the PCA cannot be unselected and will always be displayed.

5.7.2 Knee State Evaluation

The Knee State Evaluation provides quantitative information about soft tissue and range of motion as the surgeon proceeds with a stress test of the patient’s knee:

- Minimum, maximum and current flexion angle (degrees)
- Minimum, maximum and current varus/valgus angle (degrees) at various flexion angles
- Laxity in flexion and extension (mm)



If the Knee State Evaluation is selected by clicking “Apply to Workflow,” the EVALUATION button will appear in the panel buttons and will allow the surgeon to perform the stress test at different stages of the procedure (Initial, Intra-Op and Final). Conversely, if not selected, the EVALUATION button will not appear in the panel buttons and no values will be recorded by the ROSA Knee System.

5.7.3 Femoral Rotation Tool

The Femoral Rotation Tool provides quantitative information about ligament laxity (mm in flexion and extension), when the surgeon proceeds with a pull test (manually or with instruments such as a laminar spreader or Zimmer FuZion®). Femoral rotation values will be displayed and can be captured to be applied to the surgical plan.

If the Femoral Rotation Tool is selected by clicking “Apply to Workflow,” a FEMORAL ROTATION button will appear in the RESECTIONS panel that will allow the surgeon to evaluate the gaps in extension and the femoral rotation of the implant following a pull test. Conversely, if not selected, the FEMORAL ROTATION button will not appear on the surgery workflow and no values will be recorded by the ROSA Knee System.

5.7.4 Flexion Angles for Stress Tests

This option enables the activation of recording varus/valgus at 30°, 45°, 60° and 120° of flexion in the EVALUATION panel. By default, 0° and 90° cannot be unselected and will always be displayed.

5.7.5 Bone Reference Checkpoint

If the Bone Reference Checkpoint feature is enabled by clicking “Apply to Workflow,” the surgeon will be requested to acquire the position of the ROSA Bone Screws placed in the femur and tibia during the initial landmark acquisition. The BONE REFERENCE CHECKPOINT button on the bottom bar will become activated. The user will also be prompted to verify Checkpoint position before resections.

Conversely, if not selected, the Bone Reference BONE REFERENCE CHECKPOINT button will not appear in the bottom bar, no checkpoint landmark will have to be acquired and the verification will not be requested of the user before resections.

5.7.6 Kinematic Alignment (Persona CR Only)

If the Kinematic Alignment (Persona CR Only) option is enabled in the SURGEON panel by clicking Apply to Workflow, the user is prompted to evaluate the wear of the femur and tibia during the landmark acquisition. The HKA panel, accessible from the bottom bar, will display the Lateral Distal Femoral Angle (LDFA) and the Medial Proximal Tibial Angle (MPTA) once the femur and tibia landmarks are completed.

In the PLANNING panel, the implant will be positioned along the patient's pre-arthritic joint line, determined by the Distal Condyle landmarks (femur), the PTA Reference landmarks (tibia) and the wear evaluation landmarks.

Conversely, if the Kinematic Alignment option is not selected, the wear evaluation landmarks will not appear in the LANDMARK panel and no LDFA and MPTA values will be displayed in the HKA window. This option is only available for cases planned with the Persona CR implant brand. Otherwise, it will be disabled.

 When the Kinematic Alignment approach is used with the ROSA Knee System, it is highly recommended to reference the Personalized Alignment Surgical Technique (1578-GLBL-en) and follow the indications/contraindications found within that include (but are not limited to): Persona CR Implant System with the Cruciate Retaining (CR), Medial Congruent (MC) or Ultra Congruent (UC) Bearing and cemented femoral and tibia components without a stem extension. Preservation of the PCL is preferred.

5.7.7 Active Track

The Active Track feature allows the surgeon to cut without pinning the Cut Guide for the femoral distal and/or tibial proximal resections. The Robotic Arm will maintain the Collaborative mode during the corresponding resections. By default, this feature is disabled.

If the Active Track feature is enabled by selecting Apply to Distal Femur Workflow and/or Apply to Tibial Proximal Workflow, a disclaimer will be displayed to present the key precautions to take when using the Active Track feature:

- Ensure the soft tissues are protected
- Ensure the leg is stable
- Ensure the NavitrackERs are visible at all times
- Ensure the Foot Pedal is pressed at all times when resecting with Active Track

The surgeon must acknowledge the key precautions by clicking OK to proceed to the SETUP panel.

 When the Active Track feature is enabled, the surgeon will be able to perform the resection directly in Collaborative mode in the RESECTIONS panel for the corresponding cut. Conversely, if not enabled, the surgeon will enter the Pinning mode in the RESECTIONS panel and will have to pin the ROSA TKA Cut Guide to the bone and follow the conventional pinning workflow.

6. ROSA Knee Application- SETUP Panel

6.1 OR Setup

During a ROSA Knee procedure, it is mandatory for the surgeon to stand on the same side as the Robotic Unit with the Optical Unit on the opposite side.

- The ROSA Knee application will automatically display the operated knee in the OR Setup section (right of left knee).
- The user must then select between two configurations:
 1. Surgeon on same side as operated knee
 2. Surgeon on opposite side of operated knee

 The surgeon is always on the same side as the Robotic Unit.

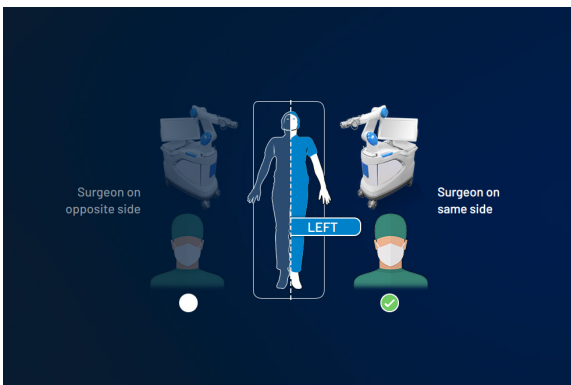

1

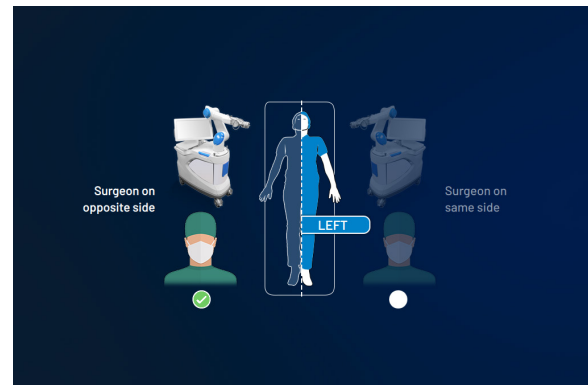

2

6.2 Calibration of Sensor

Move the Robotic Arm to DRAPING Position

1. In the SETUP panel, press and hold the Foot Pedal to move the Robotic Arm to DRAPING position.

Install the ROSA Arm Instrument Interface

1. Once the Robotic Arm is in DRAPING position, install the ROSA Arm Instrument Interface by firmly tightening the three captive screws using the hexagonal screwdriver.
2. Click NEXT to proceed to the calibration of the Force Sensor.

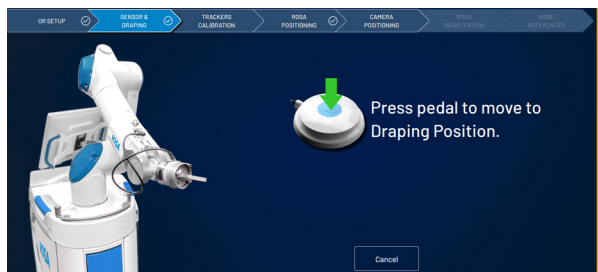

6.2 Calibration of Sensor (cont.)

- ⚠ Do not apply excessive torque on screws when installing an instrument.
Do not use power tools.

Calibrate the Force Sensor

1. Acknowledge the Robotic Arm is free of any force (checkmarks) and click YES.
 - If unsuccessful, redo calibration
 - If successful, click NEXT to proceed to draping

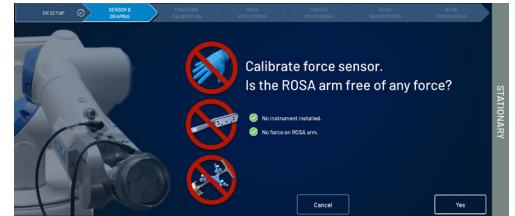

- ⚠ Do not touch the Robotic Arm. Only the ROSA Arm Instrument Interface should be installed on the Robotic Arm.

6.3 Draping

ROSA Knee can be draped using the ROSA Robotic Unit Drape or the ROSA Arm Drape combined with a standard surgical base drape.

- If using the ROSA Robotic Unit Drape, refer to the section below labeled: Install ROSA Robotic Unit Drape
- If using the ROSA Arm Drape combined with a standard surgical base drape, refer to the section below labeled: Drape the Robotic Arm and Robotic Unit

Install ROSA Robotic Unit Drape

The ROSA Robotic Unit Drape box of 20 part number is: 20-8020-080-00.

1. With the help of a non-sterile user, drape the Robotic Unit by following the instructions on the application user interface and in the IFU provided with the drape.
2. Install the blue elastic at the end of the sterile drape on the ROSA Arm Instrument Interface, ensuring the elastic does not go beyond the end of the ROSA Arm Instrument Interface.
3. Ensure the blue stripe on the ROSA Robotic Unit Drape is aligned on top of the Robotic Arm.
4. Ensure the blue circle stickers are aligned with the elbow joint of the Robotic Arm.
5. Ensure the green square stickers are aligned with the posts of the ROSA Base Reference bar.
6. Click DONE when the draping is complete.



Drape the Robotic Arm and Robotic Unit



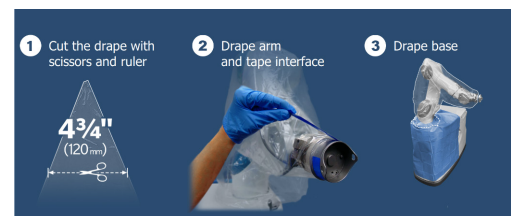

1. Cut the tip of the drape 4.75" (120 mm) from the end as indicated.
2. With the help of a non-sterile user, drape the Robotic Arm until the cut end is over the ROSA Arm Instrument Interface.
3. Tape to seal the drape around the complete circumference of the ROSA Arm Instrument Interface.
4. Install a standard surgical drape around the front and sides of the Robotic Unit base, over the Robotic Arm drape and around the lowest joint of the Robotic Arm.
5. Click DONE when draping is complete.



- ⚠ Ensure the ROSA Arm drape is not installed too tightly to allow the Robotic Arm to move freely without pulling on it. Failure to do so may result in contamination leading to potential patient infection and organ failure or dysfunction.

- ⚠ Verify the setup of the sterile drapes before beginning a surgery to ensure the asepsis of the surgical field. Failure to do so may result in contamination leading to potential patient infection and organ failure or dysfunction.

6.3 Draping (cont.)

-  The sterile drape extremity (cut end or elastic) should not go beyond the end of the ROSA Arm Instrument Interface. Failure to do so may result in contamination leading to potential patient infection and organ failure or dysfunction.
-  The tape must adhere to both the drape and the ROSA Arm Instrument Interface. Failure to do so may result in contamination leading to potential patient infection and organ failure or dysfunction.
-  The base drape must be installed over the arm drape and around the lowest joint of the Robotic Arm. Failure to do so may result in contamination leading to potential patient infection and organ failure or dysfunction.
-  Ensure that no excessive force is applied to the Force and Torque Sensor cable when installing and removing the drape.

6.4 Touchscreen Monitor Draping

1. Slide the monitor drape over the screen from top to bottom.
2. Fully unfold the drape over the screen.
3. Cover the mouse and its support with the lower part of the drape (if draping the Optical Unit Monitor).
4. Stretch the drape around the screen and tape it at the back of the screen.





6.5 Tracker Calibration

Install NavitrackERs #3 and #6 as described in section 3.5 prior to calibration.

-  Always use NavitrackER pliers for the installation. Ensure that reflective NavitrackER devices are fully seated.
1. Place the Femoral Bone Reference in the indicated zone in front of the Optical Unit.
 2. Follow the instructions on the screen to calibrate the tracker.
 3. Once the Femoral Bone Reference is calibrated, show the Tibial Bone Reference to the Optical Unit.
 4. Place the Tibial Bone Reference in the indicated zone.
 5. Follow the instructions on the screen to calibrate the tracker.

The info bubble on the upper right corner of the NavitrackERs Calibration panel provides additional instruction on how to perform the navitracker calibration

-  In case of recalibration, the digitized landmarks must be acquired again.
-  Calibration is disabled once a resection has been performed.



Please note that the tracker calibration step can be skipped and completed at any point during the OR Setup workflow, but must be completed before landmarking.

6.6 ROSA Knee Positioning

1. Install the ROSA Base Reference Frame on the ROSA Base Reference Bar over the draping on the post closest to the surgical table.
2. Install the ROSA Arm Reference Frame on the ROSA Arm Instrument Interface by firmly tightening the two captive screws by hand.
3. Click NEXT when both instruments are installed.



Verify the ROSA Arm drape is not pulled too tightly before installing the base reference, to allow the Robotic Arm to move freely. Failure to do so may result in contamination leading to potential patient infection and organ failure or dysfunction.

4. Click NEXT to proceed to the setup and registration.



The ROSA Base Reference Frame should never move during surgery.

Move the Robotic Arm to SETUP Position

1. Press and hold the Foot Pedal to move the Robotic Arm to the SETUP position.



Risk of collision: When the Robotic Unit is in Automatic mode, stay clear of the Robotic Arm and its path to the next position.

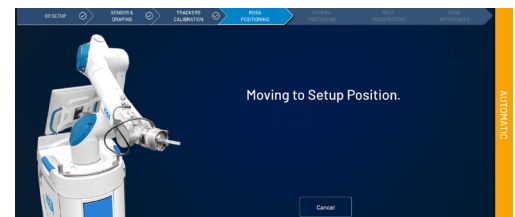

Position the Robotic Unit

1. Align the axis of the ROSA Arm Reference Frame with the patient's operative leg axis.
2. Align the end of the ROSA Arm Reference Frame (laser marked KNEE with an arrow) with the joint line of the operative knee.
3. Click NEXT to proceed to Robotic Unit immobilization.



To move the Robotic Unit, use the handle on the back of the unit. Never use the ROSA Base Reference Bar or the ROSA Base Reference Frame.



The Robotic Unit must be at approximately 45° angle to the operating table on the surgeon's side, as described in section 3.2.3 OR Setup.

Lock the Robotic Unit

1. Lock the four wheels of the Robotic Unit by pressing down on the pedal on each wheel.
2. Activate the immobilization system by pressing down the main lever in the back of the Robotic Unit.
3. Click NEXT when the Robotic Unit is locked.

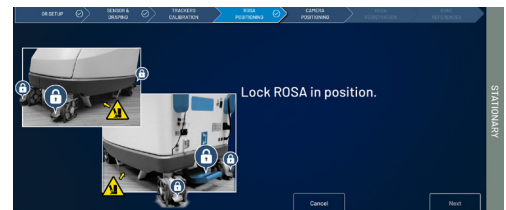

6.7 Camera Positioning

Move the Robotic Arm to CAMERA TARGET Position

1. Press and hold the Foot Pedal to move the Robotic Arm to the CAMERA TARGET position.

 Risk of collision: When the Robotic Unit is in Automatic mode, stay clear of the Robotic Arm and its path to the next position.



Position the Optical Unit

The Optical Unit should be on the opposite side of the surgeon and Robotic Unit, as shown in the user interface.

1. Follow the instructions on the screen to position the camera in the optimal position area and at the optimal height.
2. The camera is red when it is not in the optimal position. It turns green when the position is optimal.

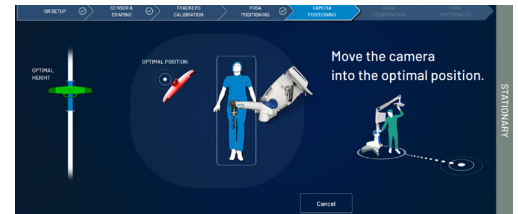

Adjust the Camera Angle

1. Angle the camera so that the laser is aiming at the center of the Navitracker installed on the ROSA Arm Reference Frame (Robotic Arm).
2. Click CONFIRM when the laser is centered on the Navitracker.



Lock the Optical Unit

1. Lock the four wheels of the Optical Unit by pressing down on the pedal on each wheel.
2. Click NEXT when the Optical Unit is locked.



6.8 ROSA Knee Registration

1. Wait for Base Reference Frame Navitracker #9 calibration to be completed.
2. Press and hold the Foot Pedal to perform the registration (six positions).

 Risk of collision: When the Robotic Unit is in Automatic mode, stay clear of the Robotic Arm and its path to the next position.

Registration Failure

If there is a failure of the registration, a notification will appear on the user interface. Verify the following and re-do the registration:

- Is the ROSA Base Reference Frame firmly tightened?
- Is the ROSA Arm Reference Frame firmly tightened?
- Is the ROSA Arm Instrument Interface firmly tightened?
- Are the Navitracker devices fully seated on the instruments?
- Were any trackers not seen or only partially seen during registration?
- Is the Robotic Unit immobilized (main lock & four wheels)?
- Has the camera moved? Is it well-positioned?

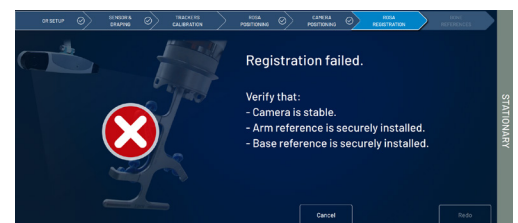
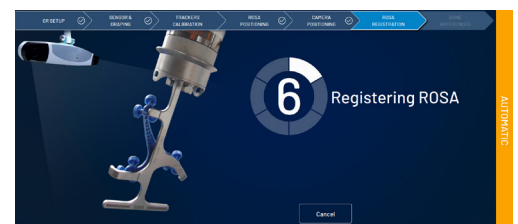
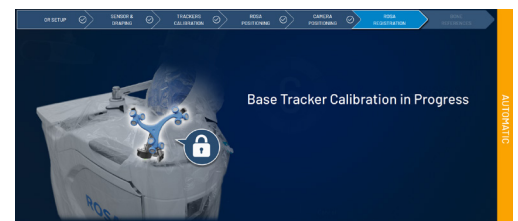

6.9 Bone References

The bone references are used to track the patient's femur and tibia and show the navigated instruments in relation to their respective positions.

Remove Instrument

1. Remove the ROSA Arm Reference Frame.

Perform Incision



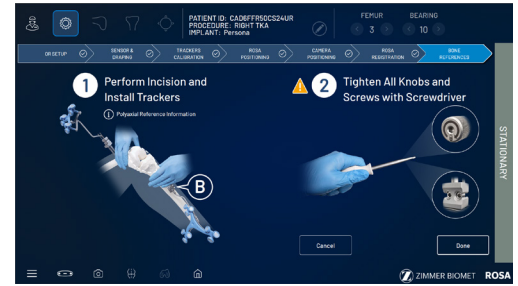

Knee incision to expose the knee for the procedure should be performed prior to installing bone references. Incision and exposure of the knee joint should be performed based on the surgeon's choice of technique.

Depending on the type of incision used, bone references and pins can be placed inside the standard incision or outside the incision, through separate stab incisions.



Install Trackers

1. Install trackers according to the procedures in section 6.9.1 and 6.9.2.
2. Click DONE when both trackers are installed to proceed to the FEMUR panel.

-  Verify the proper fixation of the bone references on the pins (femur and tibia). The bone references are secured on the pins, close to the patient's skin (without compression), using two hexagonal screws.
-  Bone references **MUST** be firmly attached to the bone and **MUST NOT** move at any moment during surgery. In case a bone reference has moved, the landmarks digitized on that bone must be acquired again.
-  Make sure that the pins are not positioned close to the bone cuts. Placing the pins close to the bone cuts location will increase the risk of breaking the pins with the cutting tools. Pin breakage may result in bone removal or non-functioning joint.
-  Beware that muscle fibers may apply bending forces on the pins.
-  Knee incision to expose the knee for the procedure should be performed prior to installing bone references.

6.9.1 Femoral Bone References

6.9.1.1 2 Pins References Femur TS3 P/N: 20-8000-010-33

The Femoral Reference can be placed either inside or outside the incision.

-  Be alert to the risk of causing damage to neurovascular structures including, to the saphenous artery and vein, femoral artery and vein, or the popliteal artery and vein while installing the bone reference.

Femoral Reference placement outside the incision

1. Place the knee in flexion to install the femoral reference.
2. Use two Fix Fluted Pins (3.2x150 mm; refer to section 3.3.3) to install the patient femoral reference (2 Pins Reference Femur TS3).
3. Position the pins four fingers proximal to the knee incision to stay clear of the working area.
 - The pins can be inserted percutaneously through the vastus medialis in the femur
 - The pins should be set near-bicortically in the bone to ensure maximum stability

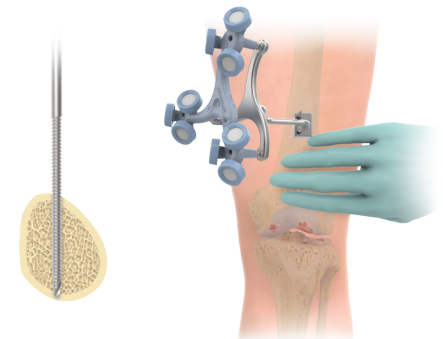



Outside Incision Femur Bone Reference Installation

6.9 Bone References (cont.)

 During Bone Reference installation, ensure tracker visibility and tool clearance through proper location and orientation, as the reference cannot be repositioned or realigned after landmarking.

4. Position the reference close to the skin (without compression or soft tissue impingement) and tighten the two screws to secure to the pins.

 The ROSA Pin Stabilizer can be used to further stabilize the interface between the bone and the pins.

 The ROSA Stabilizer Tissue Deflector can be used to ease the insertion of the ROSA Pin Stabilizer.

Femoral Reference Placement Inside the Incision

1. Position two Fix Fluted Pins (3.2x150 mm; refer to section 3.3.3) two fingers proximal to the proximal edge of the trochlea.
2. Tilt the femoral reference towards the camera to ensure tracker visibility while avoiding interference or contact between the femoral reference and the power tools, ROSA TKA Cut Guide, implant or bone pins and screws.
 - The pins should be set bicortically in the bone to ensure maximum stability
3. Position the reference close to the bone/skin (without compression or soft tissue impingement) and tighten the two screws to secure to the pins.

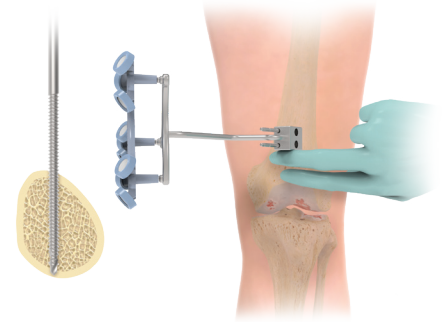

Inside Incision Femur Bone Reference Installation

 Use caution in osteoporotic bone.

6.9.1.2 ROSA Polyaxial Reference Size 3 (Femur) P/N: 20-8020-037-00

The ROSA Polyaxial Reference Size 3 (femur) can be placed either inside or outside the incision.

 Be alert to the risk of causing damage to neurovascular structures, including to the saphenous artery and vein, femoral artery and vein, or the popliteal artery and vein while installing the bone reference.

 Polyaxial Reference Optical Tracker orientations can be preset based on surgeon preference prior to each installation.

 The following Optical Tracker orientations are optimal for the ROSA Polyaxial Reference Size 3 (femur) placed inside or outside incision, based on the OR setup:

	Right Leg Operated	Left Leg Operated
Surgeon on same side as operated knee	E7	A1
Surgeon on opposite side as operated knee	A1	E7

6.9 Bone References (cont.)

Femoral Polyaxial Reference Placement Outside the Incision

1. Place the knee in flexion to install the ROSA Polyaxial Reference Size 3.
2. Insert the ROSA Pin Stabilizer four fingers proximal to the knee incision until contact with the bone is made.
 - The ROSA Pin Stabilizer can be inserted percutaneously through the vastus medialis in the femur

 ROSA Stabilizer Tissue Deflectors can be used to ease the insertion of the ROSA Pin Stabilizer.

3. Insert two Fix Fluted Pins (3.2x150mm; refer to Section 3.3.3) through the ROSA Pin Stabilizer.
 - The pins should be set near-bicortically in the bone to ensure maximum stability

 Do not remove the ROSA Pin Stabilizer from the pins. Its use is mandatory throughout the entire surgery when the ROSA Polyaxial Size 3 (femur) is fixed outside the incision.

4. Keep the ROSA Pin Stabilizer in place and slide the ROSA Polyaxial Reference Size 3 over the pins until contact with the ROSA Pin Stabilizer is made.
 - Ensure the stem of the Polyaxial Reference points towards the camera
5. Using the 3.5mm Hex Head Screwdriver, tighten the two set screws to secure the ROSA Polyaxial Reference Size 3 reference to the pins.
6. Orient the Optical Tracker, ensuring optimal line of sight with the camera. Then, firmly tighten the two knobs on the Polyaxial Reference using the 3.5mm Hex Head Screwdriver.

 Verify the knobs of the Polyaxial References are firmly tightened with the Screwdriver and DO NOT loosen at any point during surgery. If a bone reference has moved, the landmarks digitized on that bone must be digitized again.

 When using the Camera Volume Viewer feature, ensure the ROSA Polyaxial Reference Size 3 is always visible by simulating flexion, extension and laxity test leg positions.

 Avoid installing the ROSA Polyaxial Reference Size 3 in regions of interference or contact with the power tools, ROSA Cut Guide, implant, bone pins or screws.

6.9.1.2 ROSA Polyaxial Reference Size 3 (Femur) P/N: 20-8020-037-00

 Stabilize the base of the Polyaxial Reference while tightening the knobs with the screwdriver to avoid bending the pins.

 Use caution in osteoporotic bone.

Femoral Polyaxial Reference Placement Inside Incision

1. Insert two Fix Fluted Pins (3.2x150mm; refer to Section 3.3.3) two fingers proximal to the proximal edge of the trochlea.
 - The pins should be set bicortically in the bone to ensure maximum stability
2. Position the ROSA Polyaxial Reference Size 3 on the pins, close to the bone/skin (without compression or soft tissue impingement).
 - Ensure the stem of the instrument points towards the camera
3. Using the 3.5 mm Hex Head Screwdriver, tighten the two set screws to secure the ROSA Polyaxial Reference Size 3 reference to the pins.



Outside Incision Femur Polyaxial Bone Reference Installation

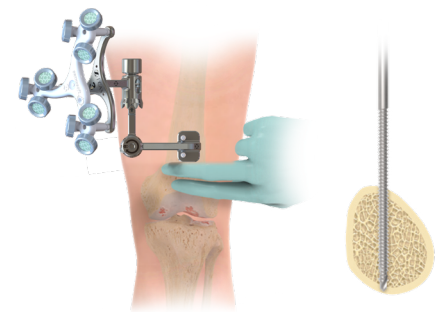

Inside Incision Femur Polyaxial Bone Reference Installation

6.9 Bone References (cont.)

6.9.1.2 ROSA Polyaxial Reference Size 3 (Femur) P/N: 20-8020-037-00

4. Orient the Optical Tracker, ensuring optimal line of sight with the camera.

Then, firmly tighten the two knobs on the Polyaxial Reference using the 3.5mm Hex Head Screwdriver.

 Verify the knobs of the Polyaxial References are firmly tightened with the Screwdriver and DO NOT loosen at any point during surgery. If a bone reference has moved, the landmarks digitized on that bone must be digitized again.

 When using the Camera Volume Viewer feature, ensure the ROSA Polyaxial Reference Size 3 is always visible by simulating flexion, extension and laxity test leg positions.

 Avoid installing the ROSA Polyaxial Reference Size 3 in regions of interference or contact with the power tools, ROSA Cut Guide, implant, bone pins or screws.

 Stabilize the base of the Polyaxial Reference while tightening the knobs with the screwdriver to avoid bending the pins.

 Use caution in osteoporotic bone.





6.9.2 Tibial Bone References

6.9.2.1 ROSA Tibia Reference A/B P/N: 20-8020-028-00/20-8020-029-00

The Tibial Reference can be placed either inside or outside the incision.

 Ensure that the pins are not placed in an area of interference with the tibial implant stem. Impact with the stem or broaching instruments can cause breakage of the pins and movement of the reference, which could result in inaccuracies. Pin breakage may result in bone removal or non-functioning joint.

 If a Persona IQ implant is used, please refer to the Pre-operative Planning sections of the Persona IQ Surgical Technique (K01-CTE-300005) for implant size +58 mm and to (K05-STB-300005) for implant size +30 mm.*

 There is an A and B Tibial Reference based on the OR setup.

Tibial Reference Placement Outside the Incision

1. Use two Fix Fluted Pins (3.2 x 80 mm refer to section 3.3.3) to install the ROSA Tibial Reference (Tibia Reference A or B).
2. Position the pins four fingers distal to the knee incision to stay clear of the working area.
 - The pins can be inserted percutaneously perpendicular to the medial surface of the tibial diaphysis
 - The pins should be set near-bicortically in the bone to ensure maximum stability
3. Position the reference close to the skin (without compression or soft tissue impingement) and tighten the two screws to secure to the pins.

*K01-CTE-300005, and K05-STB-300005 may be found on the Canary Medical website: canarymedical.com.

6.9.2 Tibial Bone References (cont.)

6.9.2.1 ROSA Tibia Reference A/B P/N: 20-8020-028-00/20-8020-029-00

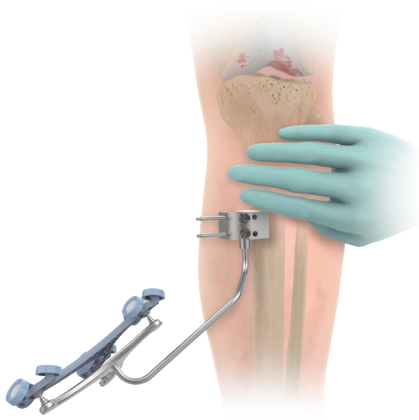

Outside Incision Tibial Bone Reference Installation



Near-Bicortical Pin Placement

Tibial Reference Placement Inside the Incision

1. Use two Fix Fluted Pins (3.2 x 80 mm refer to section 3.3.3) to install the ROSA Tibia Reference (A or B).
2. Position the pins:
 - Three fingers distal to the joint line
 - On the anterior cortex, distal and medial to the articular surface and the anticipated position of the ROSA TKA Cut Guide
 - The pins should be set bicortically in the bone to ensure maximum stability
3. Position the reference close to the bone/skin (without compression or soft tissue impingement) and tighten the two screws to secure to the pins.

 Remove the pins before final preparation to avoid breakage of the pins and movement of the reference.

 Use caution in osteoporotic bone.



Inside Incision Tibia Bone Reference Installation





Bicortical Pin Placement

6.9.2 Tibial Bone References (cont.)

6.9.2.2 ROSA Polyaxial Reference Size 6 (Tibia) P/N: 20-8020-038-00

The ROSA Polyaxial Reference Size 6 (tibia) can be placed either inside or outside the incision.

 Polyaxial Reference Optical Tracker orientations can be preset based on surgeon preference prior to each installation.

 The following Optical Tracker orientations are optimal for the ROSA Polyaxial Reference Size 6 (tibia) placed inside or outside the incision based on the OR setup:

	Right Leg Operated	Left Leg Operated
Surgeon on same side as operated knee	H3	A1
Surgeon on opposite side as operated knee	F2	C2

Tibial Polyaxial Reference Placement Outside Incision:

1. Insert two Fix Fluted Pins (3.2 x 80 mm refer to section 3.3.3) four fingers distal to the knee incision.
 - The pins can be inserted percutaneously and perpendicular to the medial surface of the tibial diaphysis
 - The pins should be set near-bicortically in the bone to ensure maximum stability

 Use caution in osteoporotic bone.

2. Position the ROSA Polyaxial Reference Size 6 on the pins, close to the skin (without compression or soft tissue impingement).
 - Ensure the stem of the instrument points towards the patient's foot (away from the incision)
3. Using the 3.5mm Hex Head Screwdriver, tighten the two set screws to secure the Polyaxial Reference to the pins.
4. Orient the Optical Tracker, ensuring optimal line of sight with the camera, then firmly tighten the two knobs by using the 3.5mm Hex Head Screwdriver.





Outside Incision tibia Polyaxial Bone Reference Installation



6.9.2.2 ROSA Polyaxial Reference Size 6 (Tibia) P/N: 20-8020-038-00 (cont.)

 Verify the knobs of the Polyaxial References are firmly tightened with the Screwdriver and DO NOT loosen at any point during surgery. If a bone reference has moved, the landmarks digitized on that bone must be digitized again.

 When using the Camera Volume Viewer feature, ensure that the ROSA Polyaxial Reference Size 6 is always visible by simulating flexion, extension and laxity test leg positions.

 Avoid installing the ROSA Polyaxial Reference Size 6 in regions of interference or contact with the power tools, ROSA TKA Cut Guide, implant, bone pins or screws.

 Stabilize the base of the Polyaxial Reference while tightening the knobs with the screwdriver to avoid bending the pins.

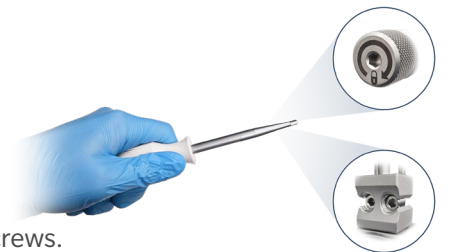

Tibial Polyaxial Reference Placement Inside Incision:

1. Insert two Fix Fluted Pins (3.2 x 80 mm refer to section 3.3.3) three fingers distal to the joint line on the anterior cortex, medio-distal to the articular surface and the anticipated position of the ROSA TKA Cut Guide.
 - The pins can be inserted percutaneously and perpendicular to the medial surface of the tibial diaphysis
 - The pins should be set bicortically in the bone to ensure maximum stability





Inside Incision tibia Polyaxial Bone Reference Installation

 Use caution in osteoporotic bone.

2. Position the ROSA Polyaxial Reference Size 6 on the pins, close to the skin (without compression or soft tissue impingement).
 - Ensure the stem of the instrument points towards the patient’s foot (away from the incision)
3. Using the 3.5mm Hex Head Screwdriver, tighten the two set screws to secure the Polyaxial Reference to the pins.
4. Orient the Optical Tracker, ensuring optimal line of sight with the camera, then firmly tighten the two knobs by using the 3.5mm Hex Head Screwdriver.



 Verify the knobs of the Polyaxial References are firmly tightened with the Screwdriver and DO NOT loosen at any point during surgery. If a bone reference has moved, the landmarks digitized on that bone must be digitized again.

 When using the Camera Volume Viewer feature, ensure that the ROSA Polyaxial Reference Size 6 is always visible by simulating flexion, extension and laxity test leg positions.

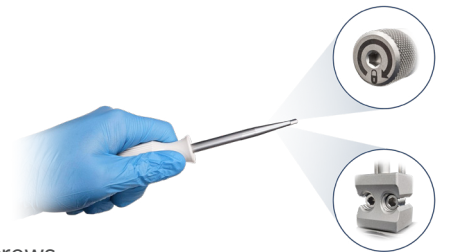

 Avoid installing the ROSA Polyaxial Reference Size 6 in regions of interference or contact with the power tools, ROSA TKA Cut Guide, implant, bone pins or screws.

 Stabilize the base of the Polyaxial Reference while tightening the knobs with the screwdriver to avoid bending of the pins.

6.9.2.3 Offset 2 Pins Reference Tibia P/N: 20-8000-010-35/20-8000-010-36

 **Only for Placement Outside the Incision**

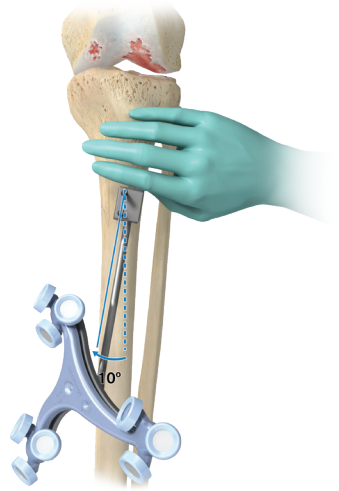

1. Use two Fix Fluted Pins (3.2 x 80 mm refer to section 3.3.3) to install the patient tibial reference. (Offset 2 Pins Reference Tibia Size 6; Right or Left).
2. Position the pins four fingers distal to the knee incision, to stay clear of the working area.
 - Orient the NavitrackER approximately 10° toward the camera
 - The pins can be inserted percutaneously into the medial surface of the tibial diaphysis
 - The pins should be set near-bicortically in the bone to ensure maximum stability
3. Position the reference close to the skin (without compression) and tighten the two set screws to secure to the pins.

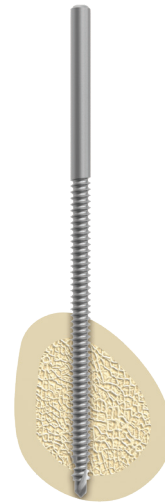

Bone Reference Installation



Near-Bicortical Pin Placement

-  Ensure that the pins are not placed in an area of interference with the tibial implant stem. Impact with the stem or broaching instruments can cause breakage of the pins as well as movement of the reference, which could result in inaccuracies. Pin breakage may result in bone removal or non-functioning joint.
-  There is a left and right Tibial Reference based on the OR setup.

6.10 Visibility Guidelines

To ensure optimal visibility of the NavitrackERs, please perform the following instructions:

1. Ensure NavitrackERs are not obstructed by suction tubes, surgical drapes, etc.
2. Ensure the anesthesia stand, IV bag fluids and other OR equipment does not interfere with the line of sight of the Optical Unit.
3. Ensure the Femoral Reference is not obstructing the tibial NavitrackER.
4. Verify the visibility of the femoral and tibial NavitrackERs throughout the flexion to extension range of motion using the Camera Volume Viewer feature.
5. Ensure the Base Tracker is visible at all times.

7. ROSA Knee Application- FEMUR Panel





Digitization of the bony landmarks is required to display the relevant information in the different panels. This system allows automatic registration of points using a stability criterion for the pointer. A movement of the instrument is first required to initiate the registration of the points. Confirmation sounds are played to advise the user that a point has been acquired successfully. The landmark to acquire will display with three colors:

White: Upcoming landmark point

Yellow: Current landmark point

Green: Successful landmark point



-  The ROSA Knee System allows the user to re-acquire all landmarks by clicking on CLEAR ALL LANDMARKS button
-  Care must be taken not to pierce through the cartilage with the ROSA Registration Pointer's tip. Avoid damaged areas and osteophytes.
-  Ensure the pointer axis is oriented perpendicular to the resection surface being acquired.
-  The user should try to match landmarks as they are displayed on the bone model on the screen.
-  The ROSA Knee System allows a single landmark to be re-acquired by clicking on the specific landmark.

Requirements for Femoral Landmarks:



- A minimal displacement of 5 mm required between two consecutive points
- A minimal distance of 20 mm must be observed between the following points:
 - Anterior and Posterior Trochlear Groove
 - Medial and Lateral Epicondyles
 - Medial and Lateral Distal Condyles

7.1 Femoral Head Center

Femoral head center detection is a crucial process that will influence the accuracy of bone resections.

1. Perform the detection of the femoral head center by recording 14 static positions of the leg.
 - For each acquired point, the leg should be stabilized until a confirmation sound is heard
 - The points should be taken in a large conical pattern with respect to the Femoral Reference
 - The minimal distance between each position is 20 mm



-  The pelvis and Optical Camera must remain motionless during the whole femoral head digitization process to ensure finding the femoral head center.
-  If a non-recommended pattern, such as two unique positions in flexion/extension or a small cone, is performed, the center of rotation algorithm will reject the result and a notification will appear asking the user to redo the acquisition.
-  The contraindications for the femoral head center detection are hip pathologies severely limiting its range of motion (e.g. arthritis and hip dysplasia).

7.2 Femoral Axis Point



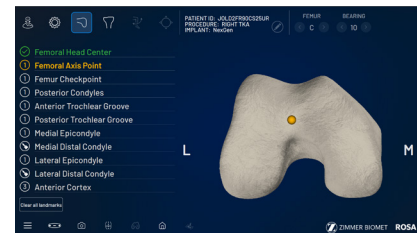

Together with the femoral head center, the Axis Point forms the femoral mechanical axis that is used as the main axis of the femoral coordinate system. The varus/valgus, flexion/extension and rotation values are computed relative to the mechanical axis.

- Using the ROSA Registration Pointer, acquire the femoral Axis Point at the deepest point of the intercondylar notch.
 - It is recommended to determine the desired axis point on a pre-operative radiograph and compare it with the intra-operative location in situ



7.3 Femur Checkpoint (Optional)

The ROSA Checkpoint Screws on the femur should be installed proximal to the joint line and anterior to the medial epicondyle.

-  Avoid installing the ROSA Checkpoint Screws in regions of interference or contact with the power tools, ROSA TKA Cut Guide, implant or bone pins. Such interferences may result in breaking the screw, which may cause bone removal or non-functioning joint.
-  Care must be taken not to over tighten the Checkpoint Screw during installation with power tools.
-  Ensure the Checkpoint Screw is fully anchored in bone and that there is no impingement of soft tissue between the bone and the bottom of the screw head.
-  Ensure the Checkpoint Screw is installed in healthy bone.



The Femur Checkpoint landmark is an optional landmark that can be used throughout the surgery to verify that the Femur Bone Reference has not moved since landmarking. The acquisition of this landmark will only be requested if the Bone Reference Checkpoint option was selected in the SURGEON Panel.



- Using the ROSA Registration Pointer, acquire the position of the divot in the head of the Checkpoint Screw placed in the femur.

7.4 Posterior Condyles

The posterior condyles are used to determine the posterior condylar axis (PCA), which is used for the femoral rotational alignment.

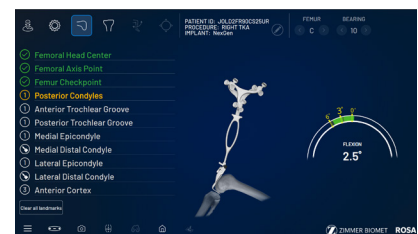
- Using the Universal Validation Tool Body with the appropriate size (Small/Medium/Large available) of ROSA Condyle Digitizer, acquire both posterior condyles at the same time.
 - Acquisition should be done between 0 and 6°, ideally at 3°
 - Knee should be flexed 90° before digitization of the points. Deep flexion assists with insertion of the instrument
 - Ensure good contact with both posterior condyles



-  Verify the proper assembly of the Universal Validation Tool Body and the ROSA Condyle Digitizer before the acquisition of the posterior condyles.
-  During acquisition, verify that the ROSA Condyle Digitizer is in contact with both posterior condyles. If proper contact is not achieved, implant sizing and posterior resection may be affected.
-  During acquisition, do not apply excessive force to the Universal Validation Tool handle. If excessive force is applied, bending of the ROSA Condyle Digitizer may occur, and posterior resection may be affected.

7.5 Anterior and Posterior Trochlear Groove

The anterior and posterior trochlear groove points are used to determine the A/P axis, which is used for the femoral rotational alignment.

1. Using the ROSA Registration Pointer, acquire the anterior and posterior trochlear groove points in the deepest portion of the trochlear groove.
 - There should be a minimal distance of 20 mm between the anterior and posterior trochlear groove points

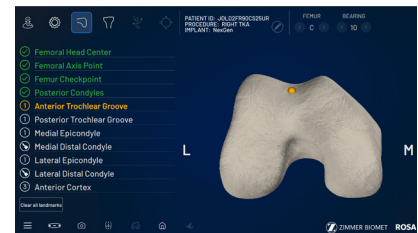

7.6 Medial and Lateral Epicondyles

The Medial and Lateral Epicondyle points are used to determine the epicondylar axis, which is used for the femoral rotational alignment. The M/L sizing of the femoral component is suggested based on these digitized points.

1. Using the ROSA Registration Pointer, acquire the Medial and Lateral Epicondyle points on the medial and lateral epicondyles.
 - There should be a minimal distance of 20 mm between the Medial and Lateral Epicondyle points





7.7 Medial and Lateral Distal Condyles

The medial and lateral most distal points are used to compute the distal resection level.

1. Using the ROSA Registration Pointer and the Foot Pedal, acquire the medial and lateral distal condyle landmarks by painting a region on each condyle.
2. Position the ROSA Registration Pointer on the correct condyle. Press the Foot Pedal to start the painting acquisition.
 - Using the on-screen recommended technique, start the painting acquisition by painting a large region on the condyle
 - Complete the painting acquisition by painting more points in the most distal region (i.e. blue zone). Once the painted surface has been successfully acquired, the application will automatically transition to the next landmark





 Care must be taken not to pierce through the cartilage with the ROSA Registration Pointer's tip. Avoid damaged areas and osteophytes.

 Final results depend on the accuracy of the painting acquisitions. For accurate results, ensure that the ROSA Registration Pointer is in contact with the bone during painting acquisition. If proper contact is not achieved, the distal resection level may be affected.

 The recommended technique for the painting acquisition is to paint the region in a medial-lateral zigzag motion in the anterior to posterior aspect of the region.

 Position the ROSA Registration Pointer on the bone before pressing the Foot Pedal.

 Keep the ROSA Registration Pointer perpendicular to the region being painted.

 Avoid painting osteophytes and other regions that should be excluded from the most distal point region.

 Painting too fast or too slowly may lead to a patchy painting surface.

 The Foot Pedal should be released before lifting the ROSA Registration Pointer off the bone to minimize outlier points for the region.

7.8 Anterior Cortex

These points digitized on the anterior cortex are used for the sizing of the femur and to assess potential for notching.

- Using the ROSA Registration Pointer, acquire a first point on the anterior cortex along the desired medial-lateral location.
- Acquire two more points on the anterior cortex inside the displayed bounding box.
 - The ROSA Registration Pointer's location is tracked in real time on the user interface using a round target with the number of remaining points to be acquired in the center (for image-based cases only)
 - The distance between each of the three points should be at least 5 mm
- Once all femur landmarks have been acquired, the application will automatically transition to the TIBIA panel.

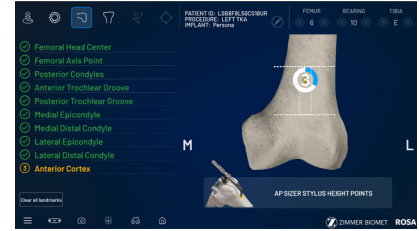

 Pick points where the AP Sizer stylus is normally positioned to assess sizing and notching.

7.9 Femur Wear Evaluation

The evaluation of the femur cartilage and bone wear is activated for the Kinematic Alignment workflow, and is used to estimate the pre-arthritic joint line by adjusting the femoral distal condyle landmarks. The PLANNING panel then positions the implant to resurface the pre-arthritic joint line. The wear evaluation will also be used to calculate the LDFA in the HKA window.



Evaluate the cartilage and bone wear on the most distal area of the distal condyles and on the posterior condyle. The options Healthy Cartilage (2 mm), Partial Cartilage Wear (1 mm) and On Bone (0 mm) are available in the drop-down menu of each condyle. When selecting On Bone (0 mm), a dial appears to enter additional bone erosion. This landmark will only be visible if the Kinematic Alignment (Persona CR Only) preference is selected in the SURGEON panel.

The DISTAL VIEWER button enables the surgeon to assess the femoral wear at the most distal points, see section 5.2.2.5.



 In the PLANNING panel, the displayed resection depth for the femoral cut is equal to 9 mm minus the wear evaluation value on each condyle.

7.10 FEMUR Panel-Error Notifications

Other error notifications are described in section 5.6. Application Visual notifications.

Femoral Head Center Error:

- The application could not determine the femoral head center. Please verify the following and perform the acquisition again:

-  - Pelvis did not move
-  - Femoral tracker is stable
-  - Camera is stable



7.10 FEMUR Panel-Error Notifications

Bone Registration Not Successful

- The application could not register the 3D bone model with the landmarks acquired. Some landmarks may have been taken at the wrong location. Two options are possible:

1. Retake the landmarks displayed by the application, starting with the one in yellow.
2. Switch to imageless (no 3D bone model). All landmarks will need to be re-acquired except the femoral head center.



If a surgeon needs to switch to the imageless option, ensure the landmarks are taken at the correct locations. The landmarks will not be verified using the 3D bone model.

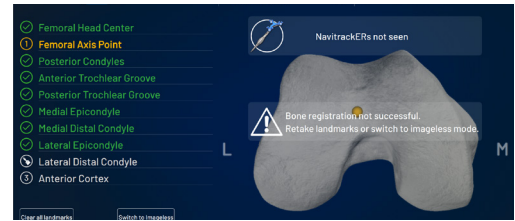

8. ROSA Knee Application- TIBIA Panel

Digitization of the bony landmarks is required to display the relevant information in the different panels. This system allows automatic registration of points using a stability criterion with the pointer. A movement of the instrument is first required to initiate the registration of the points. Confirmation sounds are played to advise the user that a point has been acquired successfully.

- ! Care must be taken not to pierce through the cartilage with the ROSA Registration Pointer's tip. Avoid damaged areas and osteophytes.
- ! The user should try to match landmarks as they are displayed on the bone model on the screen.
- ! The ROSA Knee System allows a single landmark to be re-acquired by clicking on the specific landmark.
- ! The ROSA Knee System allows the user to re-acquire all landmarks by clicking on CLEAR ALL LANDMARKS button

Requirements for Tibial Landmarks:

- A minimal distance of 20 mm must be observed between the following points:
 - PCL Insertion Point and Medial Third Tubercle
 - Medial and Lateral Plateau
- A minimal distance of 35 mm must be observed between the points located at the two malleoli.
- A minimal distance of 220mm must be observed between the ankle center and the medial third tubercle

8.1 Tibia Checkpoint (Optional)

The ROSA Checkpoint Screw on the tibia should be installed distal to the joint line and medial to the tibial tubercle.

- ! Avoid installing the ROSA Checkpoint Screw in regions of interference or contact with the power tools, ROSA TKA Cut Guide, implant or bone pins. Such interferences may result in breaking the screw, which may cause bone removal or non-functioning joint.
- ! Care must be taken not to over tighten the checkpoint screw during installation with power tools.
- ! Remove the tibial bone screw before drilling and broaching to avoid breakage of the screws.
- ! Ensure the Checkpoint Screw is fully anchored in bone and that there is no impingement of soft tissue between the bone and the bottom of the screw head.
- ! Ensure the Checkpoint Screw is installed in healthy bone.

The Tibia Checkpoint landmark is an optional landmark that can be used throughout the surgery to verify that the Tibia Bone Reference has not moved since landmarking. The acquisition of this landmark will only be requested if the Bone Reference Checkpoint option was selected in the SURGEON panel.

1. Using the ROSA Registration Pointer, acquire the position of the divot in the head of the Checkpoint Screw placed in the tibia.

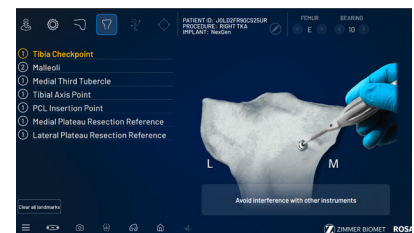

8.2 Malleoli

In order to recreate the mechanical axis of the tibia, two points are digitized on the medial and lateral malleoli. The varus/valgus, flexion/extension and rotation values are computed relative to the mechanical axis.

- Using the ROSA Registration Pointer, acquire the medial and lateral malleoli in the surgeon's preferred order.
 - A minimal distance of 35 mm between the lateral and medial malleoli points is required.

8.3 Medial Third Tubercle

The neutral tibial rotation is defined by a point in the middle of the PCL insertion area on the tibia and one on the medial third of the tibial tuberosity.

This axis should lie perpendicular to the posterior edges of the proximal tibia.

- Using the ROSA Registration Pointer, acquire a point on the medial third of the tibial tuberosity.
 - There should be a minimal distance of 20 mm between the PCL insertion point and medial third tubercle point
 - A minimal distance of 220 mm between the medial third tubercle and the ankle center is required

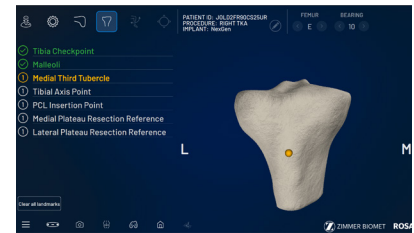

8.4 Tibial Axis Point

The tibial axis point is identified as the entrance point of the intramedullary canal.

This point should be centered along the medial/lateral axis. A/P positioning should fall between the middle and one-third of the anterior edge of the tibial plateau.

- Using the ROSA Registration Pointer, acquire the tibial axis point.



8.5 PCL Insertion Point

The neutral rotation is defined by a point in the middle of the PCL insertion area on the tibial plateau and one on the medial third of the tibial tuberosity.

This axis should lie perpendicular to the posterior edges of the proximal tibia.

- Using the ROSA Registration Pointer, acquire the PCL insertion area.
 - There should be a minimal distance of 20 mm between the PCL insertion point and medial third tubercle point

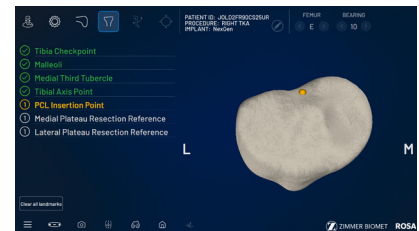

8.6 Medial and Lateral Plateau Resection References

The medial and lateral plateau resection references are used to compute the resection level, i.e. the planned tibial proximal resection will be below the acquired points.

- Using the ROSA Registration Pointer, acquire the lowest point of the medial/lateral tibial plateau.
 - There should be a minimal distance of 20 mm between the medial and lateral plateau points



Care must be taken not to pierce through the cartilage with the ROSA Registration Pointer's tip. Avoid damaged areas and osteophytes.

Once both the femoral and tibial landmarks have been acquired, the application will proceed to the EVALUATION Panel (if selected in SURGEON panel) or to the PLANNING panel.

8.7 Medial and Lateral PTA Reference

When the Kinematic Alignment option is selected in the SURGEON panel, the Medial and Lateral Plateau Resection Reference landmarks are replaced by the Medial and Lateral PTA (Proximal Tibial Angle) Reference landmarks. These landmarks, with the Tibia Wear Evaluation landmark, are used to compute the resection levels and angles, as well as the MPTA displayed in the HKA button.

- Using the ROSA Registration Pointer, acquire the medial and lateral landmarks in an appropriate location to define the MPTA and resection level.
 - The Medial and Lateral PTA Reference landmarks should have minimal offset in the anterior-posterior direction
 - There should be a minimal distance of 20 mm between the medial and lateral plateau points

8.8 Tibia Wear Evaluation

The evaluation of the tibia cartilage and bone wear is activated for the Kinematic Alignment workflow, and is used to estimate the pre-arthritic joint line by adjusting the Tibial PTA Reference landmarks. The PLANNING panel then positions the implant to resurface the pre-arthritic joint line. The wear evaluation will also be used to calculate the MPTA in the HKA window.



Evaluate the cartilage and the bone wear on the tibia plateau where the PTA Reference landmarks were taken. The options Healthy Cartilage (2 mm), Partial Cartilage Wear (1 mm) and On Bone (0 mm) are available in the drop-down menu of each plateau. When selecting On Bone (0 mm), a dial appears to enter additional bone erosion. This landmark will only be visible if the Kinematic Alignment (Persona CR Only) preference is selected in the SURGEON panel.

 In the PLANNING panel, the displayed resection depth for the tibial cut is equal to 10 mm minus the wear evaluation value on each plateau.

8.9 TIBIA Panel-Error Notifications

Other error notifications are described in section 5.6. Application Visual Notifications.

Bone Registration Not Successful

The application could not register the 3D bone model with the landmarks acquired. Some landmarks may have been taken at the wrong location. Two options are possible:

- Retake the landmarks displayed by the application (for example here: tibial canal entry and lateral plateau resection reference), starting with the one in yellow.
- Switch to imageless (no 3D bone model). All landmarks will need to be re-acquired.



 If a surgeon needs to switch to the imageless option, ensure the landmarks are taken at the correct locations. The landmarks will not be verified using the 3D bone model.

9. ROSA Knee Application- EVALUATION Panel (Optional)

After acquiring the femoral and tibial landmarks and if the option has been selected in the SURGEON panel, the user will have access to the EVALUATION panel. The surgeon performs the contact points steps on the operative knee to determine the medial and lateral contact points in flexion (85° to 95°) and extension (-5° to 20°) used for space display in the INITIAL and INTRA-OP tabs. The contact points are composed of two consecutive steps: the Alignment Pose and the Kinematic Acquisition, executed at both flexion and extension angles:

Alignment Pose:

1. Press down on the Foot Pedal.
2. Stabilize the leg while ensuring there is bone contact in the medial and lateral compartments. The Alignment Pose will be captured once the leg is stabilized.

In the kinematic acquisition step, the captured Alignment Pose corresponds to the neutral varus-valgus alignment that will be represented by the middle of the varus-valgus gauge bar in the box on the right-hand side.



Alignment Pose Step in the CONTACT POINTS Tab



Kinematic Acquisition:

1. Press down on the Foot Pedal.
2. Perform the alternating bone contact movement in each compartment until checkmarks are displayed on both sides of the varus-valgus gauge bar. The Foot Pedal icon turns into a red dot during the acquisition to indicate that values are being recorded. If the varus or valgus motion is excessive, the varus-valgus gauge bar turns orange, and a warning message is displayed.



Kinematic Acquisition Step in the CONTACT POINTS Tab

9 ROSA Knee Application-Evaluation Panel (Optional) (cont.)

-  If the knee geometry is changed, it's important to perform the contact points again.
-  The CONTACT POINTS tab is not accessible after all resections are performed.
-  Do not apply internal/external rotation on the operative knee during the Knee State Evaluation.

Once contact points are completed, the surgeon can move the operative knee through a series of optically tracked movements of the leg, recorded while pressing the Foot Pedal, to evaluate the patient's knee. The ROSA Knee System will quantify, display and save various characteristics of the knee condition. This assessment can be performed at three distinct stages of the surgery each in a different tab: INITIAL, INTRA-OP (intra-operative) and FINAL.

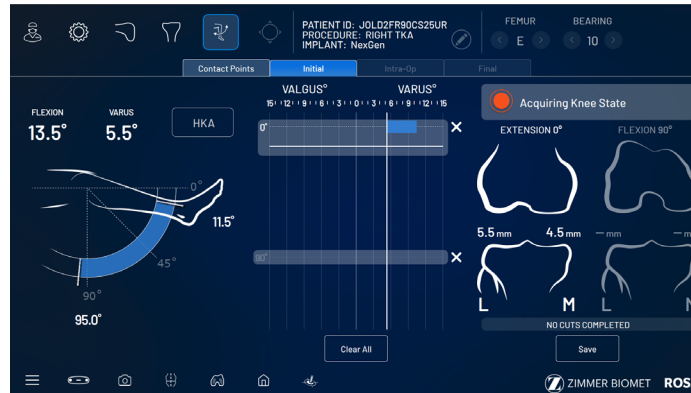

EVALUATION Panel

Range of Motion

- A movement of the leg is first required to initiate the procedure
- The surgeon can perform the range of motion test that will capture in blue the minimum and maximum flexion angles of the knee
- The HKA alignment of the leg is also displayed and can be recorded in its initial state (INITIAL tab) at any time during the procedure (INTRA-OP tab) or when the resections are completed (FINAL tab) by clicking the HKA button



Laxity Test

1. Flex the knee to a pre-set angle, then press the Foot Pedal to record varus and valgus stress. The Foot Pedal icon turns into a red dot during the acquisition to indicate that values are being recorded. Repeat for other angles of flexion.
 - By default, knee laxity is measured in full extension (0° of flexion) and at 90° flexion. Other preference-based angles are available (SURGEON panel): 30°, 45°, 60° and 120°
 - The maximum varus/valgus angle values are recorded in the indicators for each angle (blue bar)
 - The ROSA Knee System allows individual acquired values of the laxity test to reset by clicking the "X" symbol next to each angle or all values by clicking CLEAR ALL

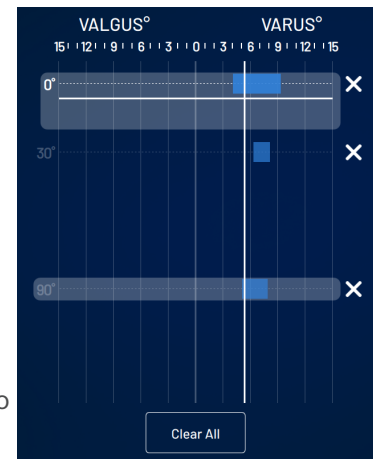

-  Varus/valgus will only be recorded when the angle line is over the highlighted box and the Foot Pedal is pressed.

9. ROSA Knee Application-EVALUATION Panel (Optional) (cont.)

Space Display

- The ROSA Knee System displays the maximum space in the medial and lateral compartments in millimeters with the knee in extension (between -5° to 20°) and in flexion ($90^{\circ} \pm 5^{\circ}$)
- At all times, the user has the option of clearing all values (CLEAR ALL) or saving the values (SAVE)

In all three tabs, the same knee assessments can be performed. The acquired values can be used to guide the surgeon in planning implant position (PLANNING panel) and can assist in clinical decisions on soft tissue management.

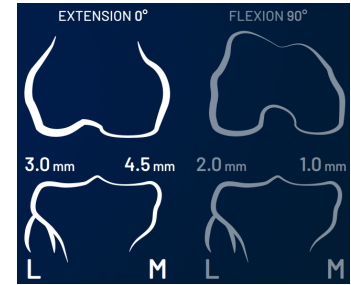

Initial Knee State

In the INITIAL tab, the knee must be in its initial condition, i.e. osteophytes may still be present or soft tissue, including the ACL, may be present regardless if it will be removed during the procedure. The INITIAL tab can be used to evaluate the Initial HKA, the pre-operative flexion contracture and the varus/valgus range of motion.

- When clicking SAVE, the user will be asked if the knee was in a prepared state for surgery during the assessment before proceeding to the PLANNING panel
- After saving the knee state assessment in the INITIAL tab, any time the user returns to the EVALUATION panel prior to finishing all cuts, the system will show the INTRA-OP tab with the latest saved values



The Balance Tool will not display the laxity values if the knee was not confirmed to be prepared for surgery.

Intra-Op Knee State

The INTRA-OP tab requires that the knee is in a representative state of when the implants will be in place, i.e., large osteophytes and the ACL and PCL (if applicable) have been removed. Since the intra-operative knee state evaluation can be done as many times as desired, the last saved values will be shown.



If the knee was not prepared for the initial knee state evaluation, when clicking SAVE in the INTRA-OP tab, the user will be asked if the knee was in a prepared state for surgery during the assessment before proceeding to the PLANNING panel.

Final Knee State

The FINAL tab becomes available upon the completion of all resections (femur, tibia and 4-in-1). The FINAL tab requires that the trials or final implants are in place during the assessment.



The final assessment with the trials or final implants should not be evaluated in the INITIAL or INTRA-OP tabs. The algorithm does not take the implant geometry into consideration.

10. ROSA Knee Application- PLANNING Panel

The PLANNING panel of the ROSA Knee application is used intra-operatively by the surgeon to set the femur and tibia bone resections and implant components. Based on the intra operatively planned values, the Robotic Arm will move to the appropriate positions to execute the surgical plan.

10.1 PLANNING Panel Overview

PLANNING Panel–Image-based Cases

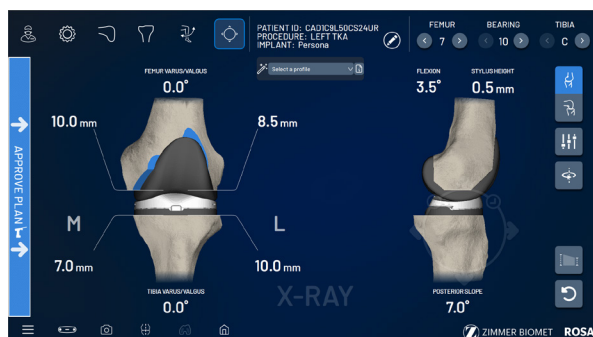

PLANNING Panel– Imageless Cases



The PLANNING panel for image-based and imageless cases displays the same functions in the top and bottom task bars, except the type and size of the tibial component cannot be selected in the imageless cases (see below). The 3D bone model is shown for both image-based and imageless cases, however the model presented for imageless cases is not representative of the actual patient anatomy. The main panel for imageless cases has an “IMAGELESS” watermark and does not offer the axial view, nor the option buttons for showing the implants, cuts, axis (always shown in flexion) and landmarks.

 A watermark indicating the imaging modality (imageless, X-RAY) is displayed at all times in the PLANNING panel.

10.1.1 Implant Selection

Implant Editor

- The implant brand, type of femoral component, type of tibial component (only for image-based cases) and instrumentation can be selected by clicking EDIT in the middle of the top task bar under CASE INFO

Refer to Appendix A to see implants supported by the ROSA Knee System.

 The user cannot select incompatible brands.

 Verify regional availability of implants prior to selection in the Implant Editor (including sizing).

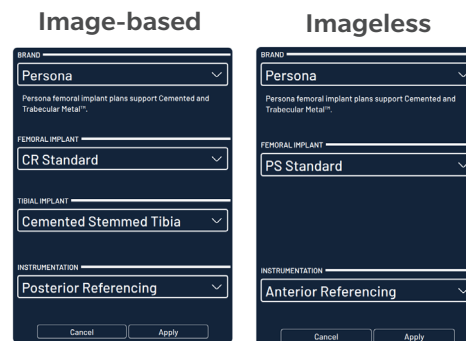

10.1.1 Implant Selection (cont.)

Implant Size Selectors

- The size of the femoral component, bearing thickness and the size of the tibial component (only for image-based cases) can be modified directly on the right side of the top task bar



10.1.2 Implant Manipulator

Image-based Cases

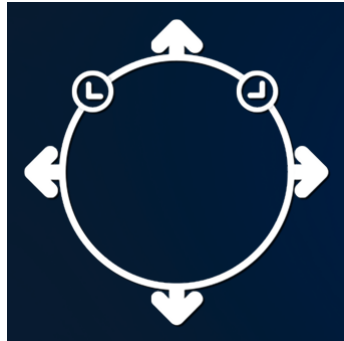

Imageless Cases

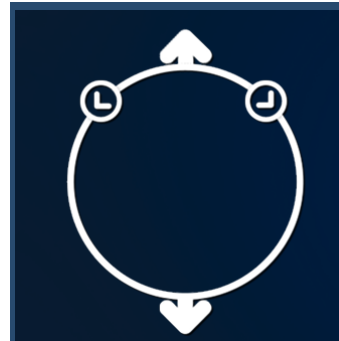

Touch the femoral or tibial component in any view: extension, flexion or axial (tibial component only), to display the implant manipulator:

- The large up/down arrows control resection
- The large side arrows control translation
- The small, encircled arrows control rotation

10.1.3 Frontal View

Image-based Cases



Imageless Cases

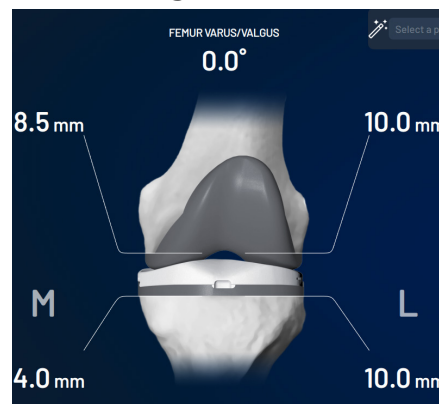

The frontal view of the PLANNING panel displays:

Femoral Bone

In flexion and extension:

- Varus/valgus angle
- Medial and lateral distal resections
- Medial and lateral posterior resections (only when Additional Resection is selected in the DISPLAY OPTIONS)

10.1.3 Frontal View (cont.)

In flexion only:

- Implant rotation angle according to different axes (PCA by default; TEA and A/P according to preferences in SURGEON panel) (when FLEXION is selected in the VIEW options)
- Assessed PCA Rotation angle based on last femoral rotation assessment (when FLEXION is selected in the VIEW options)

Tibial Bone

- Medial and lateral proximal resections
- Varus/valgus angle

10.1.4 Lateral View

Image-based Cases



Imageless Cases

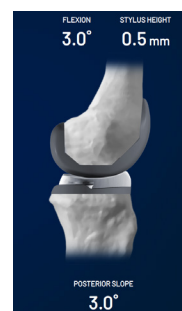

The lateral view of the PLANNING panel displays:

- Femoral Bone
 - Stylus height
 - Flexion angle
- Tibial Bone
 - Posterior slope angle

For image-based cases, when the Rotation icon is selected, it is possible to rotate the 3D bone model in the lateral view. Swipe the Touchscreen left or right to turn the 3D bone model. Note that deselecting the Rotation icon will return the 3D bone model to its original lateral view.

10.1.5 Tibia Axial View

Image-based cases



Imageless cases

No tibia axial view
for imageless cases

The tibia axial view of the PLANNING panel displays:

- Tibial component
 - Implant rotation angle

10.2 Viewing Options

For image-based cases, the viewing options of the PLANNING panel are:

- EXTENSION/FLEXION: Displays the knee in extension or flexion
- DISPLAY OPTIONS: Toggles on/off the DISPLAY OPTIONS parameters
 - IMPLANTS: Toggles the display of the implants on/off
 - CUTS: Toggles display of the cuts and proximal tibial resection line on/off
 - AXES: Toggles on/off the display of the axes (only in FLEXION view)
 - * Implant rotation angle relative to the PCA axis (default axis)
 - * Implant rotation angle relative to the TEA axis (preference-based)
 - * Implant rotation angle relative to the AP axis (preference-based)
 - LANDMARKS: Toggles on/off the display of the acquired landmarks
 - TRANSPARENCY: Toggles between a transparent and opaque visualization of the bone models
 - Additional Resections: Toggles on/off the display of the posterior resections in EXTENSION view and the distal resection in the FLEXION view
 - Implants Thickness: Toggles on/off the display of the implant thickness in the balance tool
 - Axial Tibia: Displays the knee in tibia view
 - Reset Options: Reset DISPLAY OPTIONS to their original status
- BALANCE: Displays the Balance tool
- RESTORE PRE-PLAN: Allows to revert to initial plan (Reverts to the pre-operative planning or to the Kinematic Alignment plan if Kinematic Alignment is selected in the SURGEON Panel)

For imageless cases, the viewing options of the PLANNING panel are:

- EXTENSION: Displays the knee in extension
- FLEXION: Displays the knee in flexion
- DISPLAY OPTIONS: Toggles on/off the DISPLAY OPTIONS parameters
 - AXES: Toggles on/off the display of the axes (only in FLEXION view)
 - * Implant rotation angle relative to the PCA axis (default axis)
 - * Implant rotation angle relative to the TEA axis (preference-based)
 - * Implant rotation angle relative to the AP axis (preference-based)
 - Additional Resections: Toggles on/off the display of the posterior resections in EXTENSION view and the distal resection in the FLEXION view
 - Implants Thickness: Toggles on/off the display of the implant thickness in the balance tool
 - Reset Options: Reset DISPLAY OPTIONS to their original status
- BALANCE: Displays the Balance tool
- RESTORE PRE-PLAN: Allows to revert to initial plan (Reverts to the pre-operative planning or to the Kinematic Alignment plan if Kinematic Alignment is selected in the SURGEON Panel)

Note, the Viewing Options can be set pre-operatively through ZBCP.

Image-based Cases

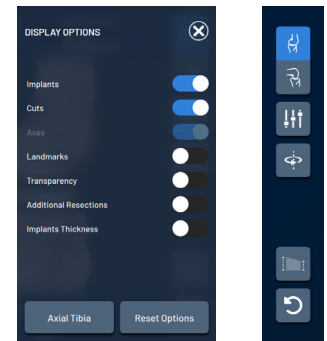

Imageless Cases

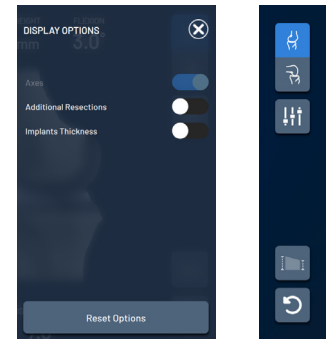

10.3 Balance Tool

The user can access the Balance Tool if the Knee State Evaluation option has been selected in the SURGEON panel and the Knee State Evaluation has been acquired. Note that the contact points are optional.

To open the Balance Tool, select the BALANCE TOOL button in the bottom left corner of the PLANNING panel.

The gaps are displayed in both flexion and extension as trapezoids. The medial and lateral gap values displayed are determined by the Knee State Evaluation values, the planned resections and the implant type and size.

If any of these values are changed, the Balance Tool is updated automatically.

By default, the Balance Tool displays total gap values. The user can switch to residual gaps (total gaps minus implant thickness) by clicking on the Balance Tool area. The info bubble on the Balance Tool's upper left corner provides additional information on total or residual gaps. Additionally, the component thickness option must be activated in the display options to be shown on the Balance Tool. Note, the total and residual gap preferences can be set pre-operatively through ZBCP.

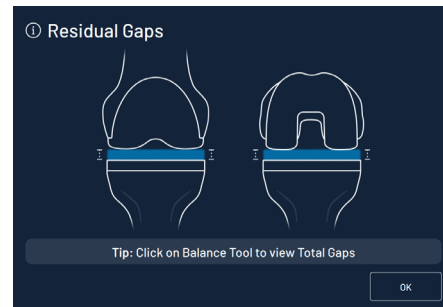
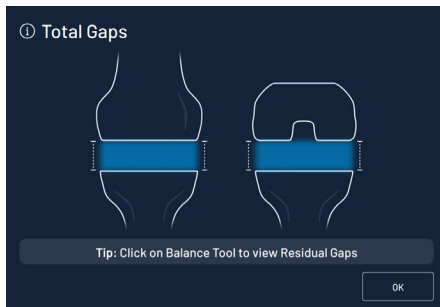

Balance Tool Information Bubbles for Total and Residual Gaps

Balance Tool Before Optional Femoral Rotation Assessment

Balance Tool After Optional Femoral Rotation Assessment

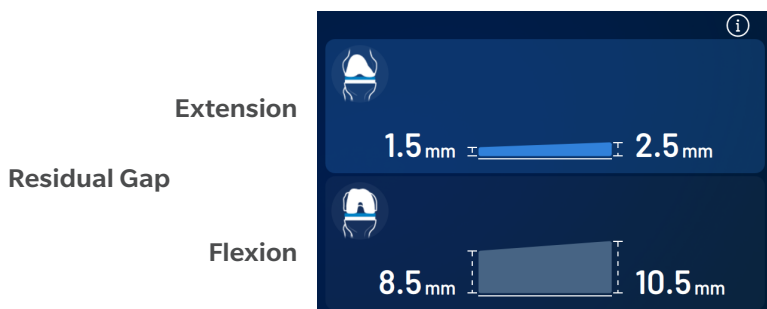
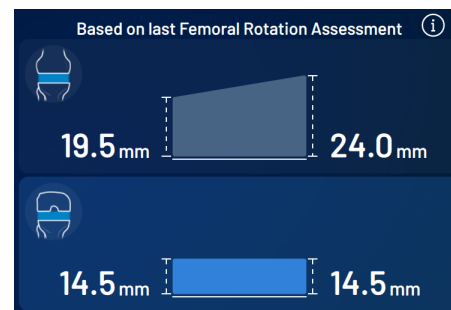
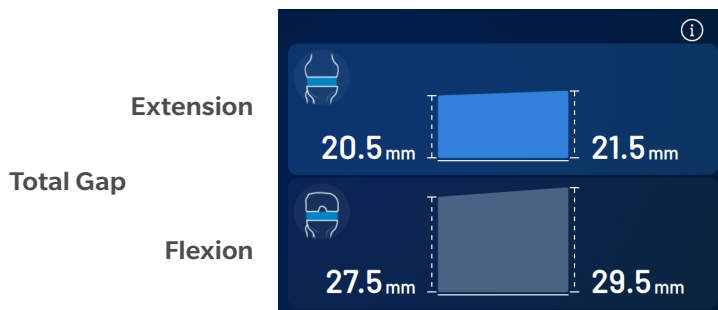

No residual Gap after Optional Femoral Rotation Assessment. Only the Total Gap will be displayed.

10.3 Balance Tool (cont.)

After the Optional Femoral Rotation Assessment

Once the femoral rotation assessment is complete, the medial and lateral gaps in extension and flexion in the Balance Tool are updated with the assessed laxity.

- Extension: The total gap is assessed with the spacer block in place
- Flexion: The total gap is assessed based on the femoral rotation assessment, which equals the distraction distance plus the planned posterior resection

10.4 Femoral and Tibial Components Planning

When Kinematic Alignment is selected in the SURGEON panel, the initial plan is based on the Distal Condyle landmarks (femur), the PTA Reference landmarks (tibia) and the wear evaluation landmarks for both image-based and imageless cases.

Otherwise, when Kinematic Alignment is not selected in the SURGEON Panel, for image-based cases, the initial plan will be based on surgeon preferences and any modifications made in the pre-operative plan. For imageless cases, the initial plan is based on surgeon preferences.

1. In the implant editor, confirm the implant brand, the femoral and tibial components and the instrumentation preference (anterior or posterior).
2. In the viewing options, set the VIEW of the knee to EXTENSION.
3. In the frontal view, set the varus/valgus angle of the femoral and tibial components.
4. In the lateral view, set the flexion angle of the femoral component.
5. In the lateral view, set the slope angle of the tibial component.
6. In the viewing options, set the VIEW of the knee to FLEXION.
7. In the frontal view, set the femoral rotation.
8. In the frontal view, set the femoral distal resection and tibial proximal resection.

Posterior Referencing Instrumentation

1. In the lateral view, set the posterior resection.
2. Select the implant size of the femoral component based on the stylus height and anterior resection.

Anterior Referencing Instrumentation

1. In the lateral view, set the anterior resection based on the stylus height.
2. Select the size of the femoral component based on the posterior bone resection.
3. In the frontal view, set the medio-lateral positioning of the femoral component.
4. In the viewing options, set the VIEW of the knee in AXIAL TIBIA.
5. Set the rotation of the tibial component.
6. Set the implant size of the tibial component.
7. Set the medio-lateral positioning of the tibial component.
8. Review the overall surgical plan.

After the Femoral Rotation Assessment

Once the femoral rotation assessment is performed (if the option is selected in the SURGEON panel), the surgical flow will return to the PLANNING panel. If the femoral rotation value following the pull test was applied to the surgical plan, review the following steps:

1. In the viewing options, set the VIEW of the knee in FLEXION.
2. In the frontal view, review the femoral distal resection and tibial proximal resection.

Posterior Referencing Instrumentation

1. In the lateral view, review the posterior bone resection.
2. Review the implant size of the femoral component based on the stylus height and anterior bone resection.

10.4 Femoral and Tibial Components Planning (cont.)

Anterior Referencing Instrumentation

1. In the lateral view, review the anterior cut based on the stylus height.
2. Review the implant size of the femoral component based on the posterior bone resection.
3. In the frontal view, review the medio-lateral positioning of the femoral component.
4. Review the overall surgical plan.

 Parameters in the PLANNING panel influence each other. Make sure to review the surgical plan before proceeding to the RESECTIONS panel.

 If a Persona IQ implant is used, please refer to the Pre-operative Planning and Sizing and Drilling of Tibia sections of the Persona IQ Surgical Technique (K01-CTE-300005) for implant size +58 mm and to (K05-STB-300005) for implant size +30 mm*.

 The Balance Tool can be used at all times to help perform the surgical plan.

10.5 Optimize Planning feature

The Optimize Planning feature simplifies the planning process by automatically positioning Persona Knee implants based on the surgeon's selected profile. Optimize Planning profiles are available in the drop-down menu positioned in the upper middle section of the planning panel.

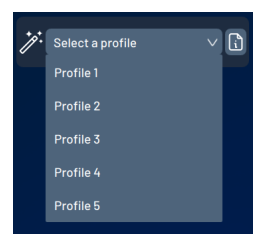

 The Optimize Planning is only available for Persona implants.

 When a profile is selected, the user can interrupt the search of a plan by clicking the CANCEL button. During the search, all other buttons are disabled and only the CANCEL button is available.

Optimize Planning profiles are created by users in ZBCP. Once created, the profiles will be included in the downloaded case. Refer to the instructions on ZBCP for any additional information on the Optimize Planning profiles and how to create them.

 Optimize Planning profiles cannot be modified intra-operatively.

Optimize Planning feature profiles are only available to the user if:

- Optimize Planning profiles were created in ZBCP
- The selected implant brand is Persona
- Knee State Evaluation is selected in the SURGEON PREFERENCE panel
- The Knee State Evaluation is completed both in flexion and in extension

Upon selecting a profile, the application will propose a plan that best matches the profile requirements. Refer to section 5.6 for the related visual notifications.

 The Optimize Planning feature does not appear in the PLANNING panel if the Knee State Evaluation is not selected.

 The Optimize Planning drop-down is disabled if the Knee State Evaluation is not completed.

 The Optimize Planning feature does not appear in the axial view.

Profile Viewer

The PROFILE VIEWER button, next to the Optimize Planning drop-down, enables the user to view the available profiles parameters. Refer to the instructions on ZBCP to modify the Optimize Planning profiles.



*K01-CTE-300005, and K05-STB-300005 may be found on the Canary Medical website: canarymedical.com.

10.5 Optimize Planning feature

- Only the CR or PS profiles that match the selected femoral implant type are displayed in the drop-down menu and in the profile viewer.

10.6 PLANNING Panel-Error Notifications

Notching

A notification will appear next to the stylus height in the lateral view when its value is equal to or less than 0 mm.

- The posterior resection and the size of the femoral component will affect notching

Implant Incompatibility

A notification will appear under the implant selector and the RESECTIONS panel will become inaccessible. Refer to Appendices B and C for implant compatibility.

- The size of the femoral and tibial components will affect implant compatibility

Planning Values Out of Range

A notification will appear in the bottom task bar (“Planning Value Out of Range”), the affected bone resection value will be displayed in orange and the RESECTIONS panel will become inaccessible.

- Bone resection and varus/valgus can be adjusted to decrease an excessive bone resection

10.7 PLANNING Limits

The planning of the ROSA Knee application has the following limit values in terms of varus/valgus, femur flexion, tibial slope, distal and proximal resection and femoral rotation:

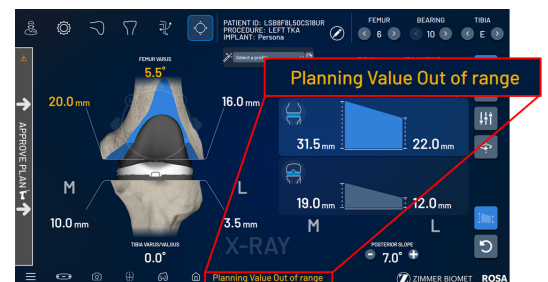
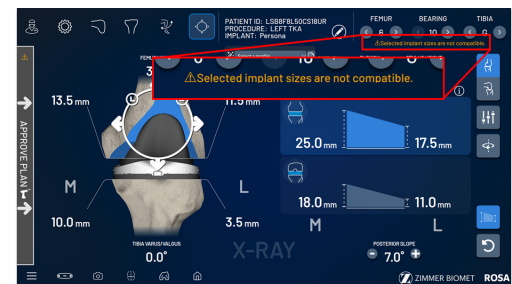
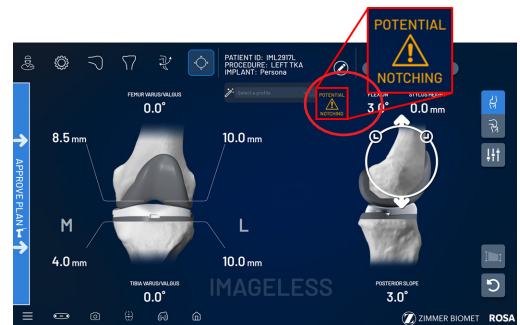

Panel Component	Femur	Tibia
Varus/Valgus	5.0° varus to 5.0° valgus for NexGen and Vanguard implants 10.0° varus to 10.0° valgus for Persona implants*	5.0° varus to 5.0° valgus for NexGen and Vanguard implants 10.0° varus to 10.0° valgus for Persona implants*
Flexion	3.0° extension to 8.0° flexion	N/A
Slope	N/A	5.0° anterior to 12.0° posterior
Resection	1.0 mm to 18.0 mm distal from the most prominent distal condyle	2.0 mm to 14.0 mm proximal from the highest tibial plateau
Axial rotation	3.0° internal to +10.0° external rotation relative to the PCA	20.0° internal rotation to 15.0° external rotation

*A disclaimer window will appear upon selecting APPROVE PLAN when the surgeon exceeds 5.0° of femur or tibia varus/valgus

10.7 PLANNING Limits (cont.)



 Clinical data by Howell et al. has suggested that joint-resurfacing techniques on pre-operative deformities, including varus deformities, do not adversely affect implant survival and function. However, the long-term outcomes of joint-resurfacing TKA with severe deviations in restored alignment remain unknown.^{1,2,3,4} Please proceed with caution and consider alternatives for patients with severe pre-operative deformities.

 Refer to specific implant system Surgical Technique for recommended implant positioning.

1. Howell, S. M., Howell, S. J., Kuznik, K. T., Cohen, J., & Hull, M. L. (2013). Does a kinematically aligned total knee arthroplasty restore function without failure regardless of alignment category?. *Clinical Orthopaedics and Related Research*®, 471, 1000-1007.
2. Rivière, C., Iranpour, F., Auvinet, E., Howell, S., Vendittoli, P. A., Cobb, J., & Parratte, S. (2017). Alignment options for total knee arthroplasty: a systematic review. *Orthopaedics & Traumatology: Surgery & Research*, 103(7), 1047-1056.
3. Courtney, P. M., & Lee, G. C. (2017). Early outcomes of kinematic alignment in primary total knee arthroplasty: a meta-analysis of the literature. *The Journal of arthroplasty*, 32(6), 2028-2032.
4. Yoon, J. R., Han, S. B., Jee, M. K., & Shin, Y. S. (2017). Comparison of kinematic and mechanical alignment techniques in primary total knee arthroplasty: a meta-analysis. *Medicine*, 96(39), e8157.

11. ROSA Knee Application- RESECTIONS Drawer

The RESECTIONS panel of the ROSA Knee application is used intra-operatively for the surgeon to perform the femoral distal resection, tibial proximal resection, the femoral rotation assessment (optional) and the femoral 4-in-1 positioning according to the chosen implant components. Based on the intra-operative planned values, the Robotic Arm will move to the appropriate positions to execute the surgical plan. The RESECTIONS panel is accessible from the PLANNING panel on the left-hand side of the screen by selecting the APPROVE PLAN button.

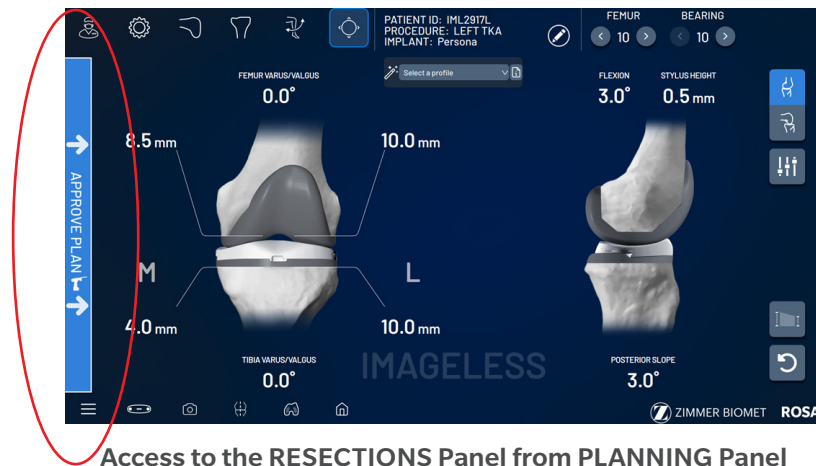

Access to the RESECTIONS Panel from PLANNING Panel

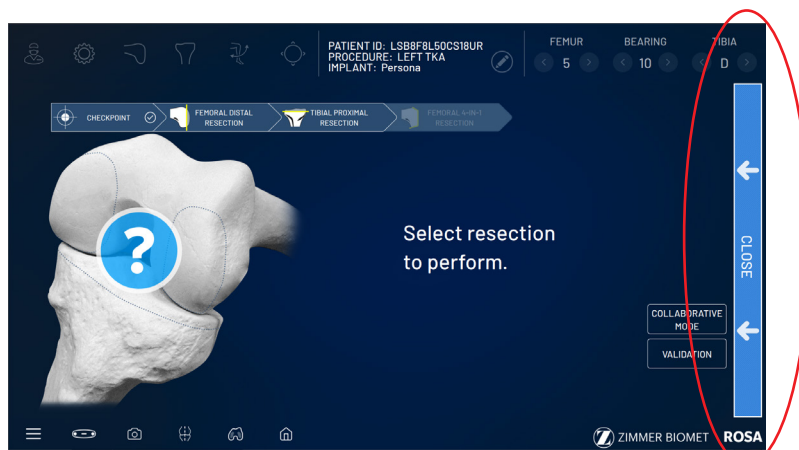

RESECTIONS Panel





11.1 RESECTIONS Panel Overview

The RESECTIONS panel is the same for both image-based and imageless cases. It consists of:

- CUT GUIDE CHECKPOINT: Allows the verification of the registration and that the correct Cut Guide is installed before performing resections
- BONE CHECKPOINT (optional): Allows for verification of the Bone Reference stability
- FEMORAL DISTAL RESECTION: Surgical flow to perform the femoral distal resection
- TIBIAL PROXIMAL RESECTION: Surgical flow to perform the tibial proximal resection
- FEMORAL ROTATION (optional): Flow to perform the femoral rotation assessment
- FEMORAL 4-IN-1 RESECTION: Surgical flow to perform the femoral 4-in-1 positioning

11.1 RESECTIONS Panel Overview (cont.)

The user can choose to start with either the femoral or tibial resection. While in the RESECTIONS panel, direct access to other panels is disabled. To access the panel buttons, close the RESECTIONS panel using the tab to the right of the screen.

-  A knee positioner, such as the De Mayo Knee Positioner, is recommended to be used with the ROSA Knee System, otherwise accuracy may be impacted.
-  The function ROSA HOME is not accessible when in a resection flow. To access this function, cancel the flow and access the feature in the RESECTIONS panel or any other panels.
-  The Cut Guide Checkpoint is performed upon entry in the RESECTIONS panel. The checkpoint also can be performed at any time when the RESECTIONS panel is accessible, to verify registration (ROSA Base Reference Frame did not move) or to confirm the correct Cut Guide is used.
-  The FEMORAL 4-in-1 RESECTION becomes accessible when the distal resection has been performed. FEMORAL ROTATION (optional) becomes accessible when the femoral and tibial resections have been performed.
-  The application displays the values from the surgical plan for the following steps: Pinning of the Cut Guide, Resecting and Validating.

There are two additional buttons available in the RESECTIONS panel:

COLLABORATIVE Mode

- Puts the Robotic Arm in Collaborative mode, where the user can manually move it by applying a gentle force to the end of the Robotic Arm while pressing down on the Foot Pedal

VALIDATION

Allows for validation of the cuts.

- Select a bone to validate resection

Femoral Distal Resection

1. Position the flat surface at the end of the Universal Validation Tool Body on the resected distal femoral surface (without the Condyle Digitizer attached).

Tibial Proximal Resection

1. Assemble the Universal Validation Tool Body with the ROSA Knee Tibia Validation Tool (or Distal & Posterior Condyles Digitizer).
2. Position the flat bottom surface of the ROSA Knee Tibia Validation Tool or the feet of the Distal & Posterior Condyles Digitizer on the resected proximal tibial surface.

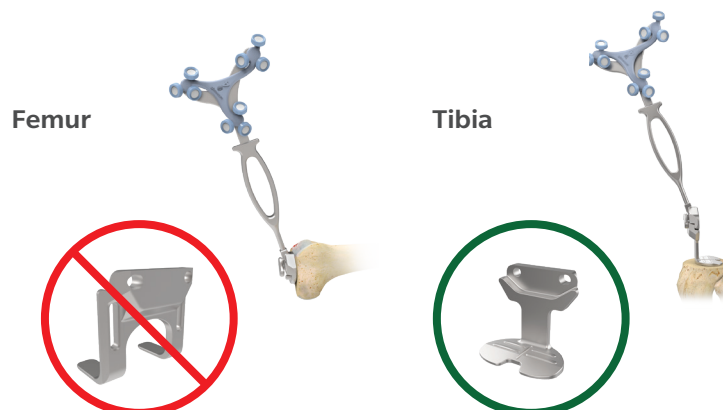

11.1 RESECTIONS Panel Overview (cont.)

- ! For the validation of the tibial proximal resection, make sure the Universal Validation Tool Body and the ROSA Knee Tibia Validation Tool (or Distal & Posterior Condyle Digitizer) are locked together using the lever.
- ! Make sure the bone resection surface is flat and free of bone fragments before validation.

11.2 ROSA TKA Cut Guide Installation and Checkpoints

Cut Guide Installation

1. Upon entry in the RESECTIONS panel, install the required ROSA TKA Cut Guide (implant family; A or B) to the ROSA Arm Instrument Interface by firmly tightening the two captive screws by hand.
2. Click NEXT to proceed to the checkpoint.

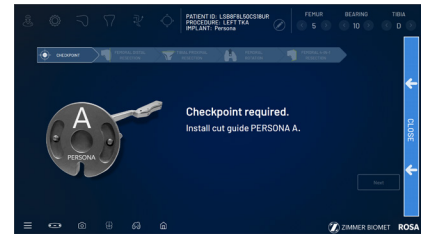

Cut Guide Checkpoint

1. Once the ROSA TKA Cut Guide is installed, place the tip of the ROSA Registration Pointer in the checkpoint (divot near the base of the Cut Guide).
2. If the checkpoint is unsuccessful, please verify the following and redo the checkpoint:
 - Is the correct ROSA TKA Cut Guide installed?
 - Is the ROSA TKA Cut Guide firmly tightened?
 - Has the ROSA Base Reference Frame moved? (If it has moved, registration of the robot needs to be redone.)

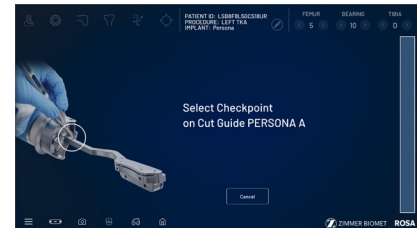

Bone Reference Checkpoint

If the Bone Reference Checkpoint option was selected in the SURGEON Panel, the BONE REFERENCE VERIFICATION panel will be displayed after the Cut Guide Checkpoint is completed.

1. Place the tip of the ROSA Registration Pointer in the Checkpoint Screw divots placed on the femur and the tibia.
2. If the Bone Reference checkpoint is unsuccessful, please verify the following and redo the checkpoint:
 - Is the Bone Screw securely installed?
 - Is the Bone Reference secure?
 - Are the NavitrackERs secure on the Bone Reference and Registration Pointer?

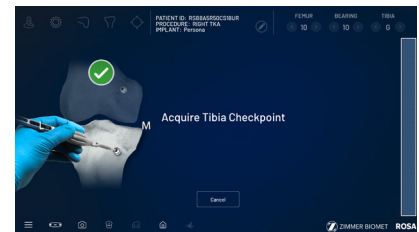

(If movement was detected and the cuts are not performed, landmarking should be redone. The user may also dismiss the step, if desired.)

11.3 Femoral Distal Resection

Select Resection to Perform

1. Select the tab for FEMORAL DISTAL RESECTION.



Automatic Mode: Robotic Arm to Cut Plane

2. Press and hold the Foot Pedal to automatically move the Robotic Arm to the femoral cut plane. Hold the Foot Pedal until the Robotic Arm switches

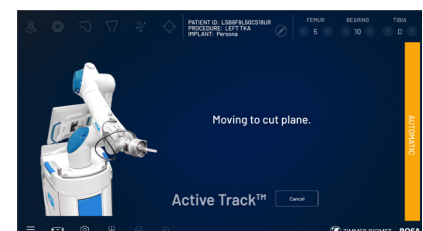

11.3 Femoral Distal Resection (cont.)

-  Risk of collision: When the Robotic Unit is in Automatic mode, stay clear of the Robotic Arm and its path to the next position.





Collaborative Mode: Robotic Arm to Cut Plane

-  Once in Collaborative mode, press and hold the Foot Pedal and apply a gentle force on the ROSA TKA Cut Guide to move the Cut Guide to the bone for pinning (pinned resection) or resecting (Active Track resection).

-  The Robotic Arm at this point is in Planar mode, i.e. its movements are restricted to the femoral cut plane only.

-  A watermark indicating the chosen resection flow (Active Track or PINNED) is always displayed in the RESECTIONS panel.

-  Continue pressing the Foot Pedal while pinning, resecting with Active Track or drilling in Collaborative mode to enable Bone Tracking mode, otherwise accuracy may be impacted. Visual and audio notifications are provided if the Foot Pedal is released in Collaborative mode.

-  Before performing the resection, it is recommended to verify the cut plane with standard instrumentation, such as the alignment rod and the resection guide (angel wing).

-  Trackers must be visible at all times during bone tracking.

Pinned Resection (default)

First Pin Installation and Live Cut Values

- Keep the Foot Pedal pressed and install the first pin in the ROSA TKA Cut Guide.
 - Make sure to use the holes labeled FEMUR for pinning.
- When the first pin is installed, confirm that the live cut values are acceptable by clicking YES.

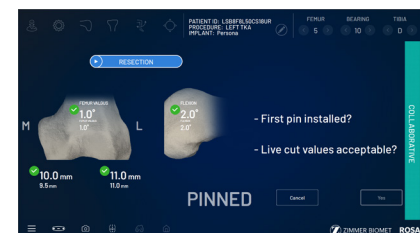

Pinning and Bone Resection

- Once the first pin installation and live cut values are confirmed, the robot is in Stationary mode and the Foot Pedal can be released. Insert the second pin and an oblique pin (if additional stability is needed).

-  Use two pins to stabilize the Cut Guide: two FEMUR pin holes with option to use oblique pin holes.



11.3 Femoral Distal Resection (cont.)

2. Perform the femoral distal resection.

- ❗ Ensure all reflective NavitrackERs are still fully seated after each resection.
- 3. Click the VALIDATION button and position the Validation tool on the distal cut. The user interface should show all green checkmarks.
 - The resection can be validated before removing the pins
- 4. Once the resection is completed, remove all pins and click the PINS REMOVED button.

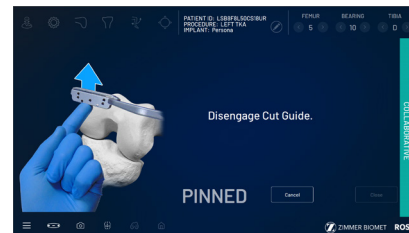

Active Track Resection (optional)

Active Track is activated if the feature was selected for the Femoral Distal workflow in the SURGEON panel.

- ⚠ Ensure to stabilize the leg when using Active Track. Failure to properly stabilize the leg during femoral distal resection may lead to ligament or tissue damage.

- ❗ An option to revert to the pinning flow is available at any time during the resection flow while using the Active Track feature.

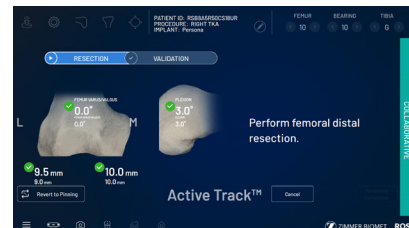

Bone Resection

- ❗ The user must acknowledge ROSA TKA Cut Guide placement by looking at live cut values.
 1. Keep the Foot Pedal pressed and perform the distal femur resection.
 - The resection can be performed using pins by clicking on the REVERT TO PINNING button



- ❗ Ensure all reflective NavitrackERs are still fully seated after each resection.
 2. Click on the VALIDATION button and position the Validation Tool on the distal cut. The user interface should show all green checkmarks.
 - During VALIDATION, the Foot Pedal needs to be released before proceeding with the acquisition of the validated values
 - The Foot Pedal can be pressed to transition back to the RESECTIONS panel, if necessary
 3. Once the resection is completed, click on the RESECTION COMPLETED button.

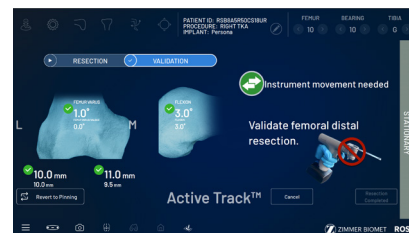

- ❗ While performing the Distal Femur resection, a distinct visual notification will appear if the Foot Pedal is released or if the Femoral Tracker or ROSA Base Reference Frame NavitrackERs are not visible to the Optical Unit.

- ❗ Do not perform any resection when in the VALIDATION sub-panel.

- ❗ The Foot Pedal must be pressed at all times during bone tracking.

- ❗ The use of a knee positioner, such as the De Mayo Knee Positioner, is strongly recommended to ensure leg stability and protect soft tissues.

- ❗ For highest precision, use Zimmer Biomet saw blades (25090127XG1, 25090137XG1).

11.3 Femoral Distal Resection (cont.)

Disengaging the ROSA TKA Cut Guide

 Before disengaging the ROSA TKA Cut Guide for a pinned resection make sure that all pins are removed.

1. Press and hold the Foot Pedal and disengage the ROSA TKA Cut Guide by applying a gentle force to pull it away until the desired position is reached. Then click CLOSE.
 - If the cut was not previously validated, the system will prompt the user to validate the cut

 If the validated flexion values are triggering a potential notching, a notification will be displayed. The user must consider recutting and/or verifying the potential for notching with the angel wing prior to anterior resection.

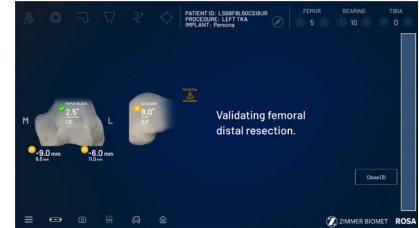

11.4 Tibial Proximal Resection

Select Resection to Perform

1. Select the tab for TIBIAL PROXIMAL RESECTION.



Automatic Mode: Robotic Arm to Cut Plane

1. Press and hold the Foot Pedal to automatically move the Robotic Arm to the tibial cut plane. Hold until the Robotic Arm switches to Collaborative mode.



Risk of collision: When the Robotic Unit is in Automatic mode, stay clear of the Robotic Arm and its path to the next position.

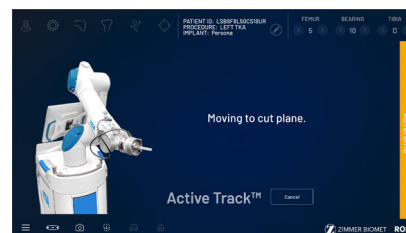

Collaborative Mode: Robotic Arm to Cut Plane

1. Once in Collaborative mode, press and hold the Foot Pedal and apply a gentle force on the ROSA TKA Cut Guide to move it to the bone for pinning (pinned resection) or resecting (Active Track resection).

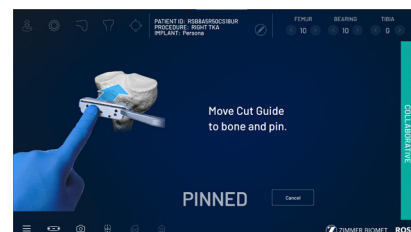

Continue pressing the Foot Pedal when pinning, resecting with Active Track or drilling in Collaborative mode to enable Bone Tracking mode, otherwise accuracy may be impacted. Visual and audio notifications are provided if the Foot Pedal is released in Collaborative mode.



For the validation of the tibial proximal resection, make sure the Universal Validation Tool Body and ROSA Knee Tibia Validation Tool (or Distal & Posterior Condyle Digitizer) are locked together using the lever.



Trackers must be visible at all times during bone tracking.



A watermark indicating the resection flow chosen (Active Track or PINNED) is always displayed in the RESECTIONS panel.



Before performing the resection, it is recommended to verify the cut plane with standard instrumentation, such as the alignment rod and the resection guide (angel wing).



The Robotic Arm at this point is in Planar mode, i.e. its movements are restricted to the tibial cut plane only.



Ensure all reflective NavitrackERs are still fully seated after each resection.

Pinned Resection (default)

First Pin Installation and Live Cut Values



Ensure consistent tension on the retractors in the wound prior to confirming that the first pin is installed

1. Keep the Foot Pedal pressed and install a first pin in the ROSA TKA Cut Guide.
 - Make sure to use the holes labeled TIBIA for pinning
2. When the first pin is installed, confirm that the live cut values are acceptable by clicking YES.

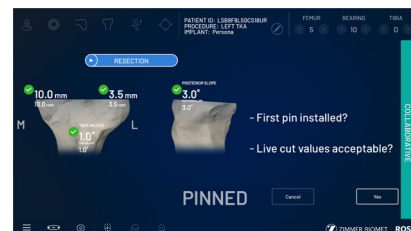

11.4 Tibial Proximal Resection (cont.)

Pinning and Bone Resection

- Once the first pin installation and live cut values are confirmed, the robot is in Stationary mode and the Foot Pedal can be released. Insert the second pin and an oblique pin (if additional stability is needed).



Use two pins to stabilize the ROSA TKA Cut Guide: two TIBIA pin holes with option to use oblique pin holes.

- Perform the tibial proximal resection.



Ensure all reflective NavitrackERs are still fully seated after each resection.

- The resection can be validated before removing the pins. Click on the CUT VALIDATION button and position the validation tool on the proximal cut. The user interface should show all green checkmarks.
- Once the resection is completed, remove all pins then confirm by clicking PINS REMOVED button.

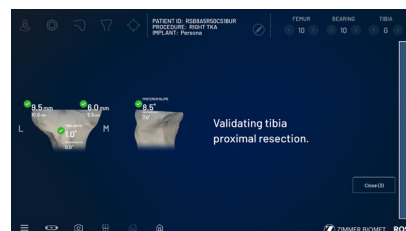

Active Track Resection (optional)

Active Track is activated if the feature was selected for the Tibial Proximal workflow in the SURGEON panel.



Ensure to stabilize the leg when using Active Track. Failure to properly stabilize the leg during femoral distal resection may lead to ligament or tissue damage.

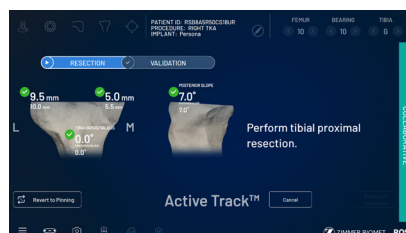

An option to revert to the pinning flow is available at any time during the resection flow while using the Active Track feature.

Bone Resection



The user must acknowledge ROSA TKA Cut Guide placement by looking at live cut values.

- Keep the Foot Pedal pressed and perform the tibial proximal resection.
 - The resection can be performed using pins by clicking on the REVERT TO PINNING button

Ensure all reflective NavitrackERs are still fully seated after each resection.



- Click on the VALIDATION button and position the Validation Tool on the proximal cut. The user interface should show all green checkmarks.
 - During VALIDATION, the Foot Pedal needs to be released before proceeding with the acquisition of the validated values
 - The Foot Pedal can be pressed to transition back to the RESECTIONS panel, if necessary

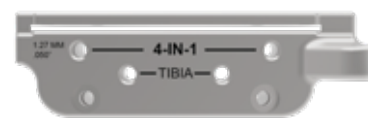



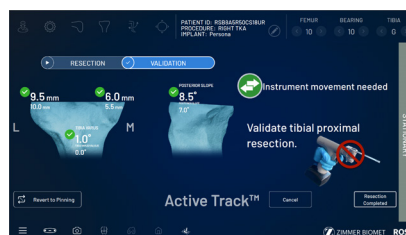

- Once the resection is completed, click on the RESECTION COMPLETED button.



While performing the Distal Femur resection, a distinct visual notification will appear if the Foot Pedal is released or if the Femoral Tracker or ROSA Base Reference Frame NavitrackERs are not visible to the Optical Unit.

11.4 Tibial Proximal Resection (cont.)

Bone Resection

-  Do not perform any resection when in the VALIDATION sub-panel.
-  The Foot Pedal must be pressed at all times during bone tracking.
-  The use of a knee positioner, such as the De Mayo Knee Positioner, is strongly recommended to ensure leg stability and protect soft tissues.
-  For the validation of the tibial proximal resection, make sure the Universal Validation Tool Body and ROSA Knee Tibia Validation Tool (or Distal & Posterior Condyle Digitizer) are locked together using the lever.
-  For highest precision, use Zimmer Biomet saw blades (25090127XG1, 25090137XG1).

Disengaging the Cut Guide

-  Before disengaging the ROSA TKA Cut Guide for a pinned resection make sure that all pins are removed.
 1. Press and hold the Foot Pedal and disengage the the ROSA TKA Cut Guide by applying a gentle force to pull it away until the desired position is reached.
 2. If the cut was not previously validated, the system will ask to validate the cut.

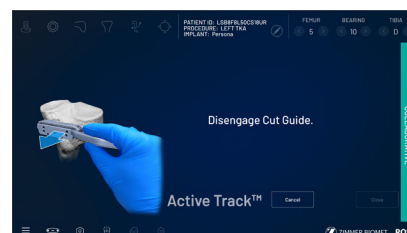

11.5 Femoral Rotation (Optional)

This option will be accessible only if the Femoral Rotation tool was included by selecting “Apply to Workflow” in the SURGEON panel.

Tibial Proximal Resection Validation

1. Validate the tibial proximal resection as described in section 11.4.
 - Acquisition will be recorded and a transition to the validation of the femoral distal resection will be done automatically
2. To revalidate, click VALIDATE TIBIA.



For the validation of the tibial proximal resection, make sure the Universal Validation Tool Body and ROSA Knee Tibia Validation Tool (or Distal & Posterior Condyle Digitizer) are locked together using the lever.



Femoral Distal Resection Validation

1. Validate the femoral distal resection as described in section 11.3.
2. Acquisition will be recorded and transition to the display of validation values will be done automatically.



Display of Validation Values

Once both resections have been validated, all values will be displayed.

1. Click NEXT to evaluate the extension gap.
2. Click VALIDATE FEMUR to redo the femoral validation, if necessary.
3. Click CANCEL to return to the RESECTIONS panel’s main panel.



Leg Positioning

1. Move the leg to extension (-5° to 20° flexion).
 - Transition to the extension gap assessment will be done automatically

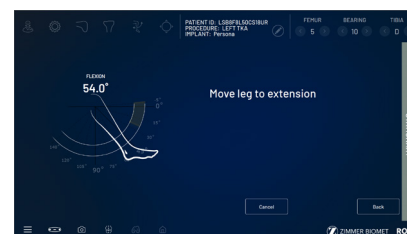

11.5 Femoral Rotation (Optional) (cont.)

Extension Gap Assessment

1. Insert a spacer block in the joint.
2. Assess the extension gaps by stressing the knee in varus and valgus, while keeping the leg in extension (-5° to 20°).
3. Modify the BEARING THICKNESS in the software to adjust the plan
4. Click the X symbol to clear the acquired values.
5. Click NEXT to proceed to the Femoral Rotation Assessment.
6. Click BACK to return to VALIDATION or CANCEL to return to the RESECTIONS panel's main panel.



Bearing thickness in the femoral rotation tool shall be adjusted according to spacer block used for assessment.

Femoral Rotation Assessment

1. Put the leg in flexion ($95^{\circ} \pm 5^{\circ}$).
2. Perform a pull test (manually or with instruments, such as a laminar spreader or Zimmer FuZion) to assess the femoral rotation needed to balance the flexion gaps.
3. Click CAPTURE to record the femoral rotation value.

Apply Femoral Rotation to Planning

Once the femoral rotation has been captured, the value will be displayed according to TEA and PCA axes.

- Three options are then available:
 - APPLY: Apply the rotation to the surgical plan
 - REDO: Redo the pull test
 - DO NOT APPLY: Returns to PLANNING without applying the rotation to the surgical plan

If the captured femoral rotation value is out of application limits,  the applied rotation will be limited to 3° internal and 10° external from PCA.

Return to Planning: Balance Tool

If the femoral rotation is applied to the surgical plan, the application will go back to the PLANNING panel. The assessed rotation values will be displayed and reflected in the Balance Tool.

1. Review the planning steps related to femoral rotation (section 10.4).

11.6 Femoral 4-in-1 Resection

Select Resection to Perform

1. Select the tab for FEMORAL 4-IN-1 RESECTION.

Automatic Mode: Robotic Arm to Femur

1. Press and hold the Foot Pedal to automatically move the Robotic Arm to the femur until the Robotic Arm switches to Collaborative mode.



Risk of collision: When the Robotic Unit is in Automatic mode, stay clear of the Robotic Arm and its path to the next position.

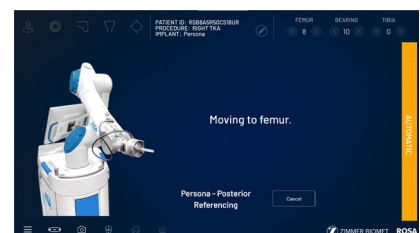
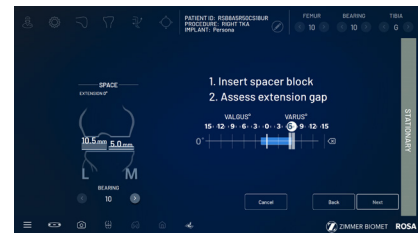

11.6 Femoral 4-in-1 Resection (cont.)

Collaborative Mode: Robotic Arm to Femur

1. Once in Collaborative mode, press and hold the Foot Pedal and apply a gentle force on the 4-IN-1 Cut Guide to move it to the bone for drilling the 4-in-1 holes.

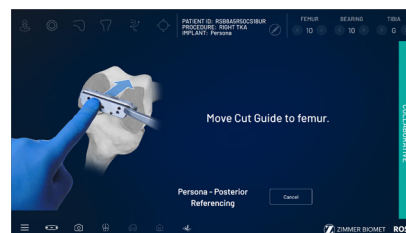

 The Robotic Arm at this point is in Planar mode, i.e. its movements are restricted to the femoral 4-IN-1 plane only.

First Pin Installation and Live Cut Values

1. Verify the appropriate instrumentation (implant brand and reference; e.g. Persona – Posterior Referencing).
2. Verify that the mediolateral (ML) position of the 4-IN-1 Cut Guide is correct.
3. Keep the Foot Pedal pressed and install a first pin in the 4-IN-1 Cut Guide on the medial side.
 - Make sure to use the holes labeled 4-IN-1 for the 1st pin (medial)



4. When the first pin is installed, confirm that the live cut values are acceptable by clicking YES.

 Continue pressing the Foot Pedal when pinning or drilling in Collaborative mode to enable Bone Tracking mode, otherwise accuracy may be impacted. Visual and audio notifications are provided if the Foot Pedal is released in Collaborative mode.

 The user interface indicates the correct 4-in-1 Cut Guide to use by displaying the brand and referencing (e.g. Persona–Posterior Referencing).

 The user must acknowledge Cut Guide placement by looking at live cut values and deciding whether they are acceptable by clicking the YES button.

Drilling of 4-IN-1 Holes

Once the ML position, live cut values, and first pin installation have been confirmed, the robot is in Stationary mode and the Foot Pedal can be released.

-  1. Drill the lateral 4-IN-1 hole.
2. Remove all pins then confirm by clicking PINS REMOVED button.
 - Make sure to use the holes labeled 4-IN-1

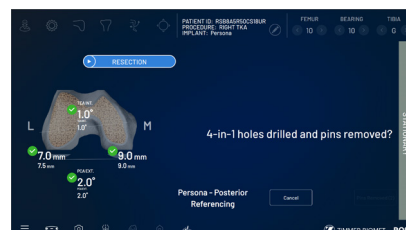

 Before performing the resection, it is recommended to verify the cut planes, especially the anterior and posterior cuts, with standard instrumentation, such as the resection guide (angel wing).

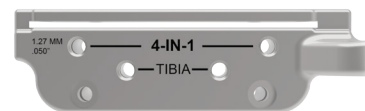

 Before disengaging the 4-IN-1 Cut Guide for a pinned resection, make sure that all pins are removed.

Disengaging the Cut Guide

1. Press and hold the Foot Pedal and disengage the 4-IN-1 Cut Guide by applying a gentle force to pull it away until the Robotic Arm reaches the desired position.
2. When desired position is reached, click CLOSE.

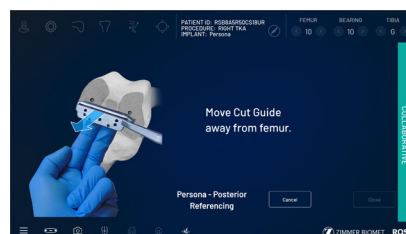

11.6 Femoral 4-in-1 Resection (cont.)

4-in-1 Bone Resections

 Before performing the 4-in-1 bone resections, make sure there is no notching using standard instrumentation, such as the resection guide (angel wing).

 For highest precision, use Zimmer Biomet saw blades (25090127XG1, 25090137XG1).

Persona Implants, Vanguard Implants and NexGen Implants with PRI Instruments

1. Place the appropriate 4-in-1 Cut Guide on the distal femur by aligning the two pegs on the back of the 4-in-1 Cut Guide with the 4-in-1 holes in the distal femur.
2. Secure the appropriate 4-in-1 finishing guide using two 3.2 mm hex-head screws or trocar pins in the oblique holes and perform bone resections according to the standard surgical technique.
3. Remove the bone screws and pins, and then the 4-in-1 Cut Guide.

NexGen Implants with Legacy Instruments

1. Insert headless pins in the two 4-in-1 holes of the distal femur.
2. Place the NexGen 4-in-1 finishing guide onto the distal femur, over the headless pins.
3. Position the finishing guide mediolaterally by sliding it on the headless pins.
4. Secure the NexGen 4-in-1 finishing guide using two 3.2 mm hex-head screws or trocar pins in the oblique holes and perform bone resections according to the standard surgical technique.
5. Remove the bone screws and pins, and subsequently the 4-in-1 cut guide.

 Ensure all reflective NavitrackERs are still fully seated after each resection.

11.7 Checkpoint Screw Removal

If the Bone Reference Checkpoint feature was selected, a “Remove Checkpoint Screws” notification will be displayed after the 4-in-1 resection is completed.

1. Remove the Checkpoint Screws from the femur and tibia.
2. Click CONFIRM to confirm the Checkpoint Screw removal and proceed with Final Knee State Evaluation (if applicable) or Certify Data.

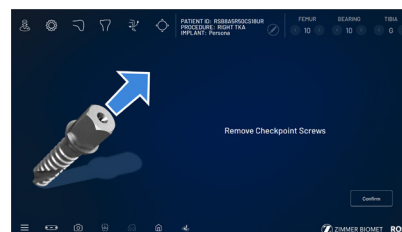

11.8 RESECTIONS Panel—Error Notifications

Camera Movement During Resections (Femur, Tibia, 4-in-1)

If the camera is moved outside a certain volume, a notification will be displayed.

1. Reposition the camera within the registration volume and click NEXT to continue.
2. Click CANCEL and go to SETUP to redo the registration step (section 6.7).

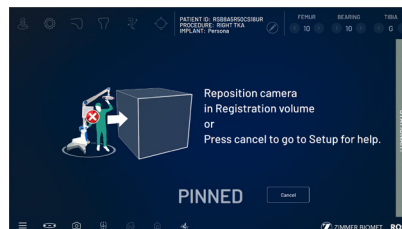

Knee Movement in Stationary Mode

If at least one live cut value is outside 2° or 2 mm, a notification of “Knee movement detected” will be displayed.

1. Try to reposition the knee so that all checkmarks turn green.
2. If the issue cannot be resolved, click CANCEL, remove all pins then restart the cut flow.

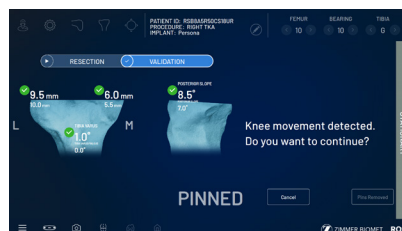

Ensure ROSA Knee is Not Pinned to the Patient

When the surgical flow is cancelled during any bone resections, the user interface will display a notification to ensure the Robotic Unit is not pinned to the patient.

1. Remove pins connecting the ROSA TKA Cut Guide to the patient.
2. Click CONFIRM once the ROSA TKA Cut Guide is unpinned.

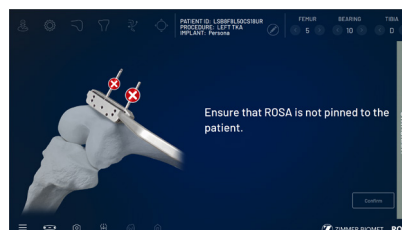

11.9 Final Knee State Evaluation (Optional)

With trial implants in place (or final implants), it is possible to perform a final Knee State Evaluation. Please refer to section 9 ROSA Knee Application–EVALUATION Panel.

11.10 Confirm Data

Following completion of the 4-in-1 Resection workflow and the Final Knee State Evaluation (if applicable), the surgeon will be prompted to confirm the final case data.

1. Review and save the final implant selection:
 - Brand
 - Component type and size
 - Bearing thickness
 - Bearing type
 - If necessary, changes can be made in the implant selector in the top task bar
 - Note that the bearing type drop-down changes based on the selected implant
2. Review the Final HKA and Knee State Evaluation.
3. Select the appropriate option and then confirm:
 - Save data with trial components
 - Save data with final Implants
 - Not to save the data displayed

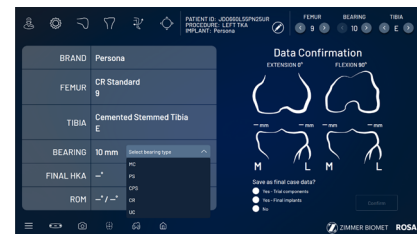

11.11 Removal of Instrumentations

1. Loosen Bone Reference set screws using the 3.5 mm screwdriver.
2. Remove the Bone References from the Fix Fluted Pins.
3. Remove the Fix Fluted Pins from the patient's bones using a power tool on the reverse setting. Avoid bending the pins to ensure safe removal.



Loosen Bone Reference set screws using the 3.5 mm screwdriver.

12. Robotic Errors

Collision Detection

If a collision is detected in Automatic mode, the Robotic Arm will automatically stop, switch to Stationary mode and a notification will appear on the user interface.

MANUAL DISENGAGE: If the ROSA TKA Cut Guide is pinned to the patient, or if there is an obstacle in the way:

1. Remove pins (if applicable).
2. Confirm that the Robotic Unit is not pinned to the patient.
3. Return to the RESECTIONS panel's main panel.
4. Choose the Collaborative mode feature to manually disengage the Robotic Arm.

CONTINUE: If there are no more obstacles, restart to Automatic mode.

ROSA Knee is Realigning

This notification will appear when the leg was moved too fast and the Robotic Arm could not follow in Tracking mode. At this point, the robot is locked in Planar mode, aligned with the bone resection plane. When the Active Track feature is enabled in the Distal Femur and/or Tibial Proximal resections, it is important to stop cutting the bone until the notification disappears.

1. Keep the Foot Pedal pressed, wait for the Robotic Arm to readjust (Automatic mode) and reach the bone resection plane again, then the notification will disappear.
2. Or click CANCEL to exit the cut flow.

Cannot Reach Position

This notification will appear if the Robotic Arm can no longer reach the femur or the tibia. Verify that:

- Leg is in flexion and not in abduction or adduction
- ROSA Base Reference Frame is stable (checkpoint passes)
- Bone references have not moved since landmark selection

If the knee was repositioned, click **RETRY** to resume the surgical workflow or click **CANCEL** to exit the cut flow.

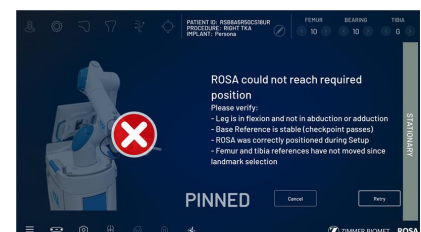
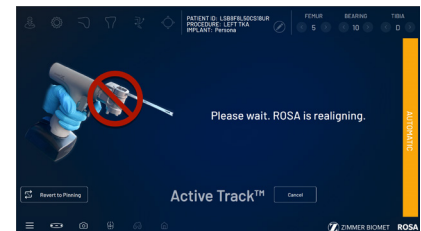
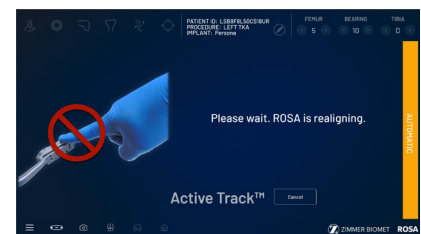
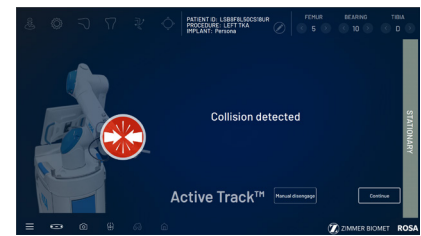

12. Robotic Errors (cont.)

Drifting of the Robotic Arm

Although the system cannot detect drifting (no notification), it is very easy to recognize. With the Foot Pedal pressed in Collaborative mode, the Robotic Arm will move without applying any force on it. Please verify:

- **Draping:** make sure the draping is not pulling on the end of the Robotic Arm where the Force Sensor is located
- **Force Sensor:** The Force Sensor was calibrated with a tool on the Robotic Arm. Go back in the SETUP panel to re-calibrate the Force Sensor

Red EMERGENCY Button

To stop the Robotic Arm at any time, press down on the red EMERGENCY button. An error message will be triggered. The EMERGENCY button is located on the Robotic Unit near the base of the Robotic Arm.

1. Press down to activate.
2. Turn clockwise to release.
3. Upon the release of the EMERGENCY button, follow the Force Sensor auto-recalibration (see below).



 To prevent hazardous situation from contact between Robotic Arm and patient, user or objects, the EMERGENCY button can be used to stop unwanted robotic movement.

Excessive Force on the Robotic Arm

In case of an excessive force on the Robotic Arm, a notification will appear on the user interface:

- **EXCESSIVE FORCE ON ROSA** (shown in bottom task bar): the force applied is more than 70% of load limit and the surgical flow will not be interrupted
- **ROBOTIC ERROR** (pop-up window): when the force applied reaches 100% of load limit, an error message will be triggered, the flow is interrupted and a procedure needs to be followed (see below)



Force Sensor Auto-Recalibration

An error message will trigger an auto-recalibration of the Force Sensor.

1. Ensure no excessive force is applied to the Robotic Arm.
2. Ensure the red EMERGENCY button is released.
3. Click RESUME to resume the surgery.
4. User will be asked to acknowledge that ROSA is not pinned to the patient and then click on YES button.



13. Post-operative Guide/ Maintenance

13.1 Retrieval of Post-Surgical Log File

13.1.1 Surgeon Report

The Surgeon Report is intended for research purposes and can only be requested by the surgeon.

This report is generated by the ROSA Knee application for each procedure and contains the following information:

- Surgeon name and surgery date
- Case ID and procedure
- Patient gender and age
- Time spent on each surgical step
- Pre-operative plan
- Each set of knee state evaluation data for INITIAL, INTRA-OP and FINAL tabs
- Each set of femoral rotation assessment results
- Intra-operative plan prior to performing the associated bone workflow
- Each validation of cuts data
- Final implant selection

The Surgeon Report will be transferred to a USB drive provided by the surgeon.

To get the Surgeon Report once the surgery is completed:

1. Close the application.
2. Click on the SURGEON REPORT button associated with the case for the report that is requested.
3. Insert a USB drive in any of the Robotic Unit's USB Ports.
4. Acknowledge that you are the surgeon responsible for this case and click NEXT.
5. Enter the PIN associated with the case.
6. Click GENERATE.

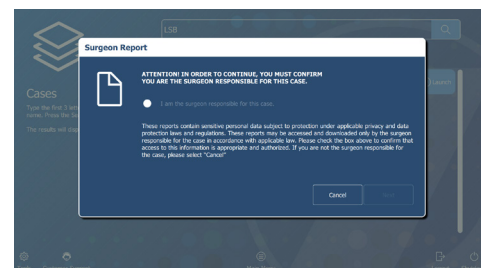
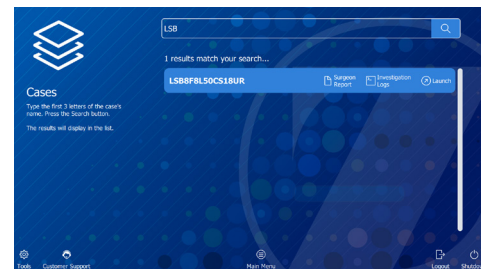

13.1.2 Investigation Logs

The Investigation Logs are intended for the assessment of a specific adverse event or product complaint and can only be requested by a Zimmer Biomet Complaint Handler on behalf of the hospital or surgical team. This report is generated by the ROSA Knee application to provide the entire software logs specific to a patient case under investigation and contains the following information:

- System computers' identification information and list of installed programs
- System computers' logs
- Case specific logs

The Investigation Logs file is securely encrypted and can therefore be transferred to a standard USB drive.

To get the Investigation Logs once the surgery is completed:

1. Close the application.
2. Click on the INVESTIGATION LOGS button associated with the case for which the report is requested.
3. Insert a USB drive into any of the Robotic Unit's USB ports.
4. Acknowledge that the download is related to a specific adverse event or product complaint and click NEXT.
5. Enter the PIN associated with the case.
6. Click GENERATE.

Investigation Logs

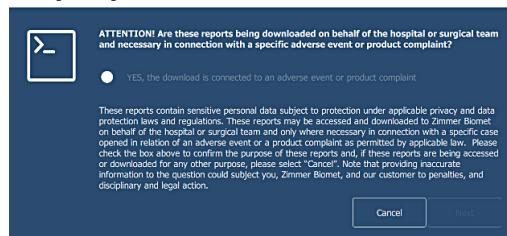

13.2 Shutdown

Click on the MENU button on the left of the bottom task bar. Select QUIT to have the following three options:

- Quit and send Robotic Arm to the PARK position
- Quit only
- Cancel



Risk of collision: When the Robotic Unit is in Automatic mode, stay clear of the Robotic Arm and its path to the next position.



By quitting the ROSA Knee application, the user interface will return to the case management application (refer to section 4.6 Case Management Application). Click SHUTDOWN to power down the device.



Wait 10 seconds after the extinction of the Touchscreen to turn the power switch of the device to “0” for the operating system to shut down properly. Turn the power switch to the “0” position.

To restart the device, wait at least 10 seconds after shutting down and for the RESET button light to turn off.



1. Remove the Power Cable from the power supply plug.
2. Disconnect the Optical Unit from the Robotic Unit.
3. Clean the Robotic and Optical Units (refer to section 13.3).



All wastes and residues must follow the hospital recycling guidelines.

13.3 Cleaning, Disinfection and Sterilization

13.3.1 Cleaning the Robotic and Optical Units

Make sure the device is turned off and unplugged before cleaning.

After each use, clean the covers, panels and the Robotic Arm with a damp cloth with mild disinfectant, ethanol (70%) or Isopropyl Alcohol (70%).



Failure to follow instructions for cleaning of the Robotic Unit may result in contamination leading to patient infection and organ failure or dysfunction.

Use a mild alkaline detergent, if necessary, to remove scuffs and stains. Do not use any solvents that may damage or discolor paint finishes or plastic components. Read the labels of the cleaning products carefully. Both the cloth and the cleaning product must be approved for use in an operating room.

Robotic and Optical Units are not waterproof. Be careful not to spill or splash liquids where they can enter electronic assemblies.



Never attempt to clean the device when it is connected to a power supply. To avoid electrical discharges, always unplug the device from the wall outlet before cleaning or disinfecting it.



IPX0 protection: Device without special protection against the penetration of liquids. Do not pour any liquid over the device.

13.3 Cleaning, Disinfection and Sterilization (cont.)

13.3.2 Cleaning the Optical Camera

Camera Housing

Clean the camera housing only if required. Clean the whole surface of the camera using a lint-free, soft cloth dampened with a non-abrasive and mild detergent.

Illuminator Filters and Lenses

Clean the illuminator filters and lenses only if required. Carefully wipe them using a cloth that is suitable for optical glasses. Remove fingerprints and pay attention not to cause damage or scratches.



13.3.3 Instrument Reprocessing (Cleaning and Sterilization Methods)

 Before every surgery, the user must verify that all instruments have been sterilized. Be aware of the contamination and potential consequent infection risk associated with the complexity of instruments and robotic components (overall geometry, features, sharp edges). Failure to follow the cleaning and sterilization instructions may result in contamination leading to patient infection and organ failure or dysfunction.

 For reusable instruments, also refer to the instrument's package insert and Reusable Instrument Lifespan Manual. Be aware of the contamination and potential consequent infection risk associated with the complexity of instruments and robotic components (overall geometry, features, sharp edges). Failure to follow the cleaning and sterilization instructions may result in contamination leading to patient infection and organ failure or dysfunction.

 Screws/mechanisms should be checked and lubricated with a medical-grade surgical lubricant after each cleaning as determined upon inspection

Section 13.3.3.2 lists the instruments supplied by Zimmer CAS and describes the sterilization methods recommended for each instrument. Reusable instruments must be cleaned after use prior to sterilization. They should not be sterilized in the protective bag or packaging supplied with them. All sterilizations should be performed using standard and regularly maintained equipment. Reusable instruments require the following manual cleaning steps.

1. All multi-components instruments should be disassembled and pre-soaked in an enzyme solution, then scrubbed with a soft bristle brush to remove all visible soil.
2. Use a water jet to flush difficult-to-access areas and closely mated surfaces. For threaded interfaces, screw/unscrew components while flushing the areas.
3. Next, ultrasound cleaning (sonication) in an enzyme solution is recommended in all cases to complete the cleaning steps with minimum cycle times of five minutes. Cycle times of at least 10 minutes are recommended for instruments with difficult to access areas.
4. Finally, in all cases, a thorough rinse is required. Normally, screws and other mechanisms should be checked and lubricated with a medical grade surgical lubricant after each cleaning as determined upon inspection.

The above instructions that are instrument-type dependent are indicated in section 13.3.3.2 as applicable to each instrument.

13.3.3.1 Sterilization Parameters

Steam Sterilization (Autoclave)

Cycle Type	Temperature ¹	Exposure Time ¹	Minimum Dry Time ²	Minimum Cool Time ³
Pre-Vacuum	132 °C (270 °F)	4 minutes	30 minutes	30 minutes

¹ Both the given cycle temperature and time can be increased to 134°C + 3°C (273.2°F + 5.4°F) and 18 minutes according to local requirements outside of the United States such as in the European Union.

² Drying times vary according to load size and should be increased for larger loads.



³ Cooling times vary according to the type of sterilizer used, device design, temperature and humidity of environment, and type of packaging used. Cooling process should comply with ANSI/AAMI ST79.

13.3.3.2 ROSA Knee System Instrument Kit

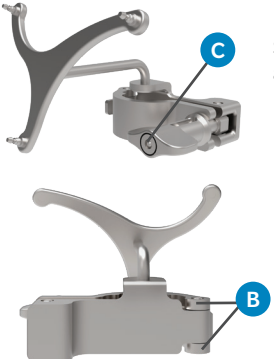
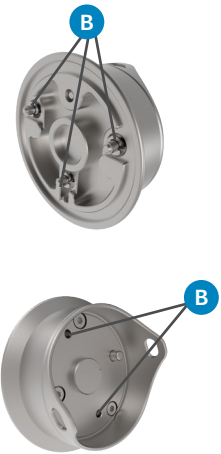

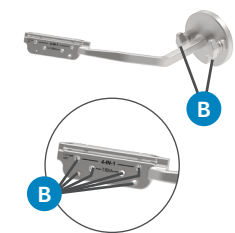

- A. Requires disassembly.
- B. Requires water jet to flush difficult to access areas.
- C. Screw/unscrew components while flushing the area.
- D. Requires a minimum of 10 minutes ultrasonic cleaning cycle in an enzymatic solution.
- E. Screws/mechanisms should be checked and lubricated with a medical grade surgical lubricant after each cleaning as determined upon inspection.

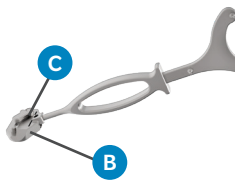
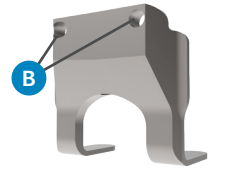
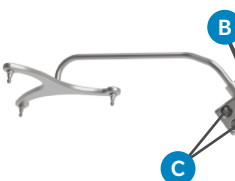
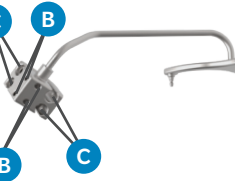

Instrument	Description	Sterilization & specific cleaning instructions	Part Number
	ROSA Base Reference Frame Sterilization & specific cleaning instructions apply both for short and long ROSA Base Reference Frames	Autoclave B C D E	20-8020-002-00
	ROSA Arm Instrument Interface	Autoclave B D E	20-8020-004-00

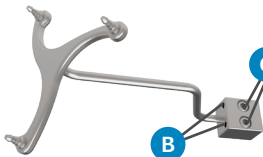
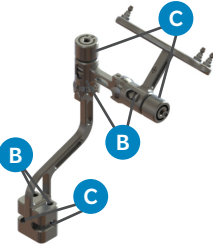
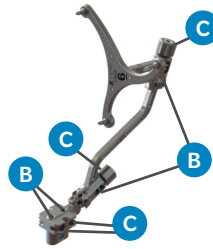
13.3.3.2 ROSA Knee System Instrument Kit (cont.)

Instrument	Description	Sterilization & Specific Cleaning Instructions	Part Number
	ROSA Persona TKA Cut Guide A ROSA Persona TKA Cut Guide B ROSA NexGen TKA Cut Guide A ROSA NexGen TKA Cut Guide B ROSA Vanguard TKA Cut Guide A ROSA Vanguard TKA Cut Guide B	Autoclave B D E	20-8020-007-00 20-8020-008-00 20-8020-009-00 20-8020-010-00 20-8020-011-00 20-8020-012-00
	ROSA Registration Pointer	Autoclave D	20-8020-013-00
	ROSA Arm Reference Frame	Autoclave B D E	20-8020-015-00
	CAS Universal Validation Tool Body	Autoclave B C D E	20-8000-010-06
	CAS Posterior and Distal Condyles Digitizer	Autoclave B D	20-8000-010-17
	ROSA Tibia Reference A	Autoclave B C D E	20-8020-028-00
	ROSA Tibia Reference B	Autoclave B C D E	20-8020-029-00

13.3.3.2 ROSA Knee System Instrument Kit (cont.)

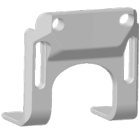
Instrument	Description	Sterilization & Specific Cleaning Instructions	Part Number
	<p>2 Pins Reference Femur – TS3 Offset 2 Pins Reference Right Tibia Size 6 Offset 2 Pins Reference Left Tibia Size 6</p>	<p>Autoclave B C D E</p> <p>Autoclave B C D E</p> <p>Autoclave B C D E</p>	<p>20-8000-010-33</p> <p>20-8000-010-35</p> <p>20-8000-010-36</p>
	<p>ROSA Polyaxial Reference Size 3</p>	<p>Autoclave B C D E</p>	<p>20-8020-037-00</p>
	<p>ROSA Polyaxial Reference Size 6</p>	<p>Autoclave B C D E</p>	<p>20-8020-038-00</p>
	<p>ROSA Pin Stabilizer, 60mm</p>	<p>Autoclave B D</p>	<p>20-8020-039-00</p>
	<p>ROSA Stabilizer Tissue Deflector, 60mm</p>	<p>Autoclave D</p>	<p>20-8020-040-00</p>
	<p>Hexagonal Screwdriver 3.5 mm</p>	<p>Autoclave D</p>	<p>00-5120-087-00</p>

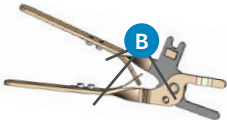
Instrument	Description	Sterilization & Specific Cleaning Instructions	Part Number
	Trocar Pin Screw Driver	Autoclave D	00-5901-021-00
	ROSA Knee Condyle Digitizer (S/M/L)	Autoclave D	20-8020-190-00 20-8020-191-00 20-8020-192-00
	ROSA Knee Tibia Validation Tool	Autoclave B D	20-8020-193-00
	CAS Navitracker Pliers	Autoclave B D	20-8000-070-05

Disposables

Description	Sterilization & Specific Cleaning Instructions	Part Number
Navitracker Kit A - Knee	Provided sterile (single use)	20-8000-000-07
Fix Fluted Pin 3.2x150 mm	Autoclave (single use)	20-8000-000-01
Fix Fluted Pin 3.2x80 mm	Autoclave (single use)	20-8000-000-02
Fix Fluted Pin 3.2x150 mm	Provided sterile (single use)	20-8000-000-10
Fix Fluted Pin 3.2x80 mm	Provided sterile (single use)	20-8000-000-11
ROSA Checkpoint Screw 13 mm, non-sterile	Autoclave (single use)	20-8020-194-00
ROSA Checkpoint Screw 13 mm, sterile	Provided sterile (single use)	20-8020-158-00
CAS 3.2 mm Headless Trocar Drill Pin, non-sterile	Autoclave (single use)	20-8000-000-16

13.3.3.3 ROSA Knee System Instrument Lifetime Expectancy

The reusable instruments of the ROSA Knee System have a lifetime expectancy of five years under normal use, estimated at 240 surgeries over five years. Before each surgery, reusable instruments must be inspected by the user for damage as per the Surgical Instrument Package Insert. For disposal, or to determine whether a reusable instrument has worn to an extent that it is no longer suitable for use, please refer to the Reusable Instrument Lifespan Manual (1219).

 Verify the integrity of all the instruments prior to each surgery. Visually inspect the instruments for damage. For reusable instruments, also refer to the instrument's package insert and Reusable Instrument Lifespan Manual.

13.4 Storage and Transport

13.4.1 Storage and Protection

13.4.1.1 Device Storage and Protection

At the end of the procedure, the device should be stored in an area fulfilling the storage conditions defined in the technical specifications.

In order to preserve the device, it should be stored in an area where there is no traffic and where it will not be exposed to fluids. The device must not be placed on sloping ground without the assurance of its stability. The immobilization system may be used during storage. During storage, ensure that the Touchscreen is folded above the Robotic Unit so that it is protected in the event of a collision.

13.4.1.2 Instruments Storage and Protection

The instruments shall remain protected from all impacts during handling and storage. Special care shall be taken for all instruments because any damage whatsoever may directly affect the registration accuracy and the positioning accuracy of instruments on a planned trajectory.

 Verify the packaging integrity (shelf box, outer package, inner package and foil pouch) and shelf life date validity and sterility indicator. Failure to do so may result in contamination leading to organ failure or dysfunction.

13.4.1.3 Care of Cables and Connectors

To avoid damage to cables, make sure the cables are not bent at sharp angles. Handle the connectors with care, paying particular attention to the following points:

- Pull connections apart by gripping the connector. Do not pull them apart by tugging on the cable as this can damage the connecting cable and connector pins
- Do not leave cable connectors where they will get damaged, particularly on the floor, where they can easily be stepped on or rolled over by heavy equipment
- Do not put heavy objects on cables or cable connectors
- Never force a connection

 Do not connect any elements to the Robotic Unit other than those provided with the device.

 In order to prevent accidental detachment of connector and to ensure EMC protection, make sure that the metallic ring of the Optical Unit Cable is attached to the hook on the Rear Panel of the Robotic Unit, if applicable.

 For safety reasons and to ensure proper functioning of the device, do not use cables other than those distributed by Zimmer Biomet.

13.4.2 Transport

13.4.2.1 Device Transport

- ⚠ When transporting the Robotic Unit, ensure that the Touchscreen is folded above the Robotic Unit so that it is protected in the event of a collision.
- ⚠ When transporting the Optical Unit, ensure that the camera is folded following the indications below so that it is protected in the event of a collision.



Transporting the device from one site (building) to another is performed only under the responsibility of the user. Any damages or malfunctions caused during transportation are not covered by Zimmer Biomet.

- ⚠ During transportation, the device can be immobilized by activating the immobilization pedal. Do not install the device on an inclined surface, unless its stability is guaranteed.
- ⚠ When transporting the Robotic Unit, ensure that Robotic Arm is in PARK position so that it is protected in the event of a collision.
- ! Activate all brakes of the Optical Unit to ensure its immobilization.
- ! Transportation or displacement of the device can be handled by one person.

13.4.2.2 Transport of ROSA Checkpoint Screws

ROSA Checkpoint Screws (Non-Sterile) must be placed between the pin brackets in the ROSA Pin Caddy for transportation.

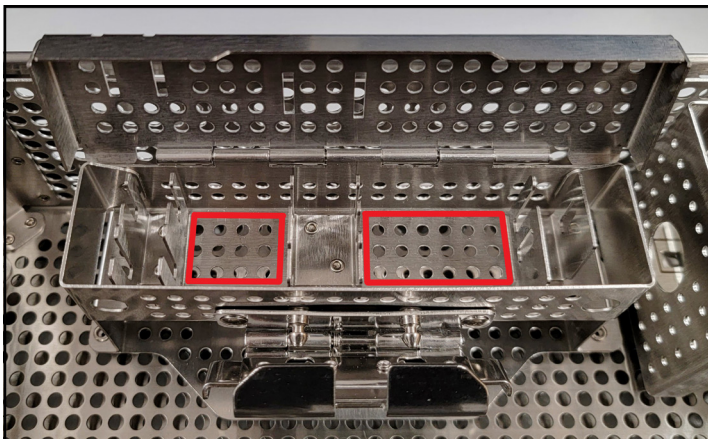

13.5 Maintenance Operations

13.5.1 Installation

The device is installed on site by Zimmer Biomet personnel only or by its approved representatives. The installation requires expert knowledge of the device by the personnel.

13.5.2 Safety Checks

Regularly perform a safety check of the device. Inspect the device to ensure no defects appear on the:

- Robotic Unit, including the Robotic Arm
- Optical Unit
- Optical Camera
- Force Sensor Connector
- Immobilization system and locks of Robotic Unit
- Foot Pedal
- Instruments

These safety checks are recommended to be done each day of use. Check the physical condition of the instruments to ensure no defects are present. Never use a distorted or damaged component.

13.5.3 Periodic Maintenance

The useful life of the product has been established at 10 years based on system testing with regular preventive maintenance performed by a qualified Zimmer Biomet Field Service Engineer or authorized Service Provider on a schedule set forth in a service plan. The established service plan covers the frequency of the preventive maintenance, every 6 months at a minimum, and identifies the different checks and tests performed. To effectuate the service plan, either a maintenance agreement for preventive and corrective maintenance may be established between the customer and Zimmer Biomet, or the customer may engage Zimmer Biomet on an event-by-event service basis, as determined by Zimmer Biomet and the customer.

Zimmer Biomet Customer Service is committed to dealing with any operational defects that may appear on the device during its useful life. Please contact your company representative before the unit reaches its end of useful life to discuss available options.



Do not open the device. In case of any issue or breakdown, do not intervene. Maintenance and service operations must only be carried out by Zimmer Biomet's Customer Service or any of its approved representatives. Do not modify the device.



When used in compliance with the indications for maintenance, the device can be used as intended.

13.6 Troubleshooting

Issue	Cause	Solution
The device does not turn on	The Power Cable is unplugged	Check that the Power Cable is connected
	The ON/OFF switch is turned to OFF	Turn the switch located on the Rear Panel of the device to ON
	Electric current is cut off by an external circuit breaker	Press on the CIRCUIT BREAKER button to reset it
	Electric current is cut off by an internal circuit breaker	Contact Zimmer Biomet Customer Service
The Touchscreen does not work	The screen is off	Turn the Touchscreen on by pressing on the button to the right side of the screen
	The screen Power Cable is unplugged	Ensure that the power, video and USB Touchscreen cables are connected
	The video cable is unplugged	
	The USB cable is unplugged	
	The screen displays the message "No video input" and then goes black. The RESET button indicator located on the Rear Panel of the device is red	Press the RESET button on the Rear Panel of the device and check that the RESET button indicator is blue
	The actions of the application do not correspond to the buttons activated. The Touchscreen is not calibrated	Contact Zimmer Biomet Customer Service
	The Touchscreen behavior is sporadic, i.e. some touches on the screen are not working	Contact Zimmer Biomet Customer Service
The CD/DVD reader does not operate	CD/DVD is unplugged and non-functional	CD/DVD cannot be used
A USB port does not work	USB port faulty	Try another USB port. Inform Zimmer Biomet Customer Service
	Connection problem with the USB port	
Case data cannot be uploaded with the USB drive	Case data is corrupted	Download the case data on the USB drive and sync again with the device. If unsuccessful, switch to imageless
	USB drive is faulty	

13.6 Troubleshooting (cont.)

Issue	Cause	Solution
The Robotic Unit immobilization system does not work	The immobilization pedal cannot go through its full range down to its locked position	Check that there is no obstacle under the stabilization feet
The Robotic Arm movement is interrupted	The device indicates detection of a collision. An unsuitable tool is installed on the Robotic Arm. The tool does not correspond to the current stage in the procedure	Ensure that the tool installed corresponds to the current stage in the procedure. Restart the movement
	The device indicates that the user interrupted movement. The Foot Pedal is turned off	Check that the Foot Pedal is connected into the Rear Panel of the device
	The light on the RESET button on the Rear Panel of the device is off and the Foot Pedal doesn't work	Contact Zimmer Biomet Customer Service
The Robotic Arm drifts slowly in Collaborative mode	An unsuitable tool is installed on the Robotic Arm. The tool does not correspond to the current stage in the procedure	Stop the Collaborative mode. Check that the tool installed corresponds to the current stage of the procedure. Launch Collaborative mode once again
	The tool is in contact with an object	Ensure that the elements secured to the Robotic Arm are not in contact with an external object
	The calibration of the Force Sensor has not been well performed	Go back to SETUP panel, SENSOR & DRAPING sub-panel and perform the calibration of the Force Sensor ensuring, no instrument is installed and no force is applied on the Robotic Arm
The interface displays a communication error message	The Force and Torque sensor cable is unplugged	Connect the cable to the Force and Torque sensor and press the RESUME button in the application.
	The red EMERGENCY button has been activated	Deactivate the red EMERGENCY button and press the RESUME button in the application.
	The Robotic Arm is not communicating with the application	The device may take up to three minutes after being switched ON for the application to communicate with the Robotic Arm. Once the three minutes has passed, press the RESUME button in the application
	The Robotic PC is not powered on correctly, and the RESET button indicator on the Rear Panel of the device is red	Press the RESET button on the Rear Panel of the device until it is blue. Then, wait three minutes to ensure that the application is communicating with the Robotic Arm, and press the RESUME button. If the RESET button indicator is still red, power OFF the system and wait one minute before powering ON again.

13.6 Troubleshooting (cont.)

Issue	Cause	Solution
Calibration is unsuccessful	Blemished NavitrackERs	Replace affected NavitrackERs and perform calibration again
	NavitrackER not installed properly	Make sure the NavitrackER is fully seated on the instrument using the NavitrackER pliers
The registration is unsuccessful	Trackers not seen	Make sure the trackers are visible during the registration
	Movement of the Robotic Unit	Verify that the Robotic Unit is immobilized (each wheel and the main immobilization system) during the registration
	Movement of the camera	Verify that the Optical Unit is immobilized during the registration
	ROSA Base Reference Frame was not installed properly	Make sure the ROSA Base Reference Frame is firmly secured
	ROSA Arm Reference Frame was not installed properly	Make sure the ROSA Arm Reference Frame is firmly secured
	ROSA Arm Instrument Interface was not installed properly	Make sure the ROSA Arm Instrument Interface is firmly secured
	NavitrackER devices were not installed properly	Make sure the NavitrackER devices are fully seated on the instruments
The Cut Guide checkpoint is unsuccessful	Wrong Cut Guide installed	Check that you have the right Cut Guide family (Persona, NexGen, Vanguard) and laterality (A or B)
	Cut Guide is loosely installed	Check that the ROSA TKA Cut Guide and Arm Instrument Interface are firmly secured
	ROSA Base Reference Frame has moved	Redo registration

13.6 Troubleshooting (cont.)

Issue	Cause	Solution
The Bone Reference Checkpoint is unsuccessful	Bone has been stripped at installation, screw is not stable	Reinstall the Bone Checkpoint Screw, and reacquire associated landmark OR Dismiss Bone Reference Checkpoint acquisition
	There is soft tissue impingement between the Checkpoint Screw and bone	
	A bone reference or NavitrackerER has moved since bone reference checkpoint acquisition	Before cut: secure bone reference, reacquire all landmarks, perform Knee State Evaluation and Planning again OR During cut: switch to standard instrumentation
The red EMERGENCY button light is on	The red EMERGENCY button has been activated	Release the red EMERGENCY button and restart the device
	The Foot Pedal triggered an error	Shut down the device and restart
The Robotic Arm or Cut Guide starts vibrating in an abnormal way	The Robotic Unit or Optical Stand is positioned in the way of the expelled airflow of the HVAC system	Check for any shift in HVAC system parameter THEN, ensure the robotic OR setup is away from the expelled airflow of the HVAC system. After moving the setup, go back to the SETUP panel and perform the setup steps again If none of the above solutions work, switch to standard instrumentation and contact Zimmer Biomet Customer Service

 The device requires specific precautions regarding the EMC. It must be installed and operated according to the EMC information provided in the User Manual.

 Portable and mobile radio frequency communication devices might affect the operation of the device.

 Usage of accessories, transducers and cables other than those specified in the User Manual, with the exception of the transducers and cables sold by Zimmer Biomet (as spare parts of internal components), might cause increased emissions or decrease immunity of the device.

 The device must not be used adjacent to or stacked on top of any other equipment. If inevitable, verify its perfect operation in the corresponding configuration.

13.7 Safe Disposal

The instruments and their components are subject to wear. The integrity of the reusable instruments must be inspected before use by the user as per the Surgical Instrument Package Insert. If instruments are no longer suitable for use as per the Reusable Instrument Lifespan Manual (1219), instruments must be returned to the local representative responsible for repair or disposal.

After use, all wastes and residues must follow the hospital recycling guidelines. Special attention must be paid to instruments that could be potential biohazards, since they may be contaminated with blood or other body fluids, bone or other tissue. Handle and dispose of products in accordance with accepted medical practice and with applicable local, state and national laws and regulations.

14. Product Security Customer Control Considerations

14.1 Records Retention & Purging Historical Data

The ROSA Recon Platform will be located at the Healthcare Delivery Organization (HDO) facility and is subject to the regulatory requirements and records retention period. After this period and upon request by the HDO, Zimmer Biomet field service engineers will assist the HDO with purging historical data from the ROSA Recon Platform.

14.2 Physical & Environmental Security Controls

The ROSA Recon Platform will be located at the Healthcare Delivery Organization (HDO) facility and is subject to the HDO's physical and environmental safeguards to mitigate the risks of loss, theft and physical tampering. The ROSA Recon Platform should be stored in a location at the HDO with physical access control to authorized personnel only when not in use.

14.3 Cybersecurity Controls

The ROSA Knee System functions in kiosk-mode for end-users. Access is restricted to the use of the case manager application and the clinical application. A Maintenance (administrative) account with a complex password unique to each ROSA Knee Robotic Unit is used by Zimmer Biomet Field Service Engineers for support and maintenance. There are no other user accounts, and privileges cannot be modified. Data containing patient information is hosted on an encrypted drive and is encrypted in transit or password-protected for data extracted by the surgeon.

! The device doesn't communicate with other systems within the customer environment and doesn't support wireless network connectivity unless the ROSA Connectivity Application is enabled. Refer to 4147-GLBL-en ROSA Connectivity - Connectivity Features of the ROSA Recon Platform for further information. For physical connections, the Ethernet port can only be used for communication with the Optical Unit. The system uses an antivirus, firewall and other security features to detect, prevent and monitor system activities for malicious behavior. Software updates, antivirus reports and firewall detections are logged, please refer to Manufacturer Disclosure Statement for Medical Device Security - MDS2.

System configuration (including hardening) is performed from the Maintenance account by a Field Service Engineer. Updates of the software are managed through periodic maintenance and can only be performed by the Field Service Engineer. Procedures for the maintenance include antivirus, application and system updates. Backups are not required as the ROSA Knee System contains a standard system image. In the event of a disruption, standard support and maintenance service level agreements (SLAs) apply.

15. Technical Data

15.1 Labels & Symbols

15.1.1 Labels

The device labels affixed on the device components are detailed below. Bar codes and 2D Matrix are examples only.

System	Countries*	Robotic Unit Label Example
110V	US, Canada, Taiwan	
220V	Australia, Austria, Belgium, China, France, Germany, Greece, Hong Kong, India, Israel, Italy, Netherlands, New Zealand, Singapore, Spain, Switzerland, UAE, UK.	

* The countries list is not exhaustive and only provides examples of where the platform could be used. Please contact your local support to determine availability in your region.

15.1.1 Labels (cont.)

System	Countries*	Robotic Unit Label Example
100V	Japan	

* The countries list is not exhaustive and only provides examples of where the platform could be used. Please contact your local support to determine availability in your region.









Optical Unit Label Example



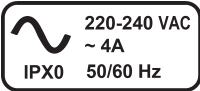
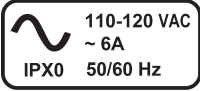
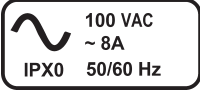











Translation Label Examples

System	Robotic Unit Label Example
Robotic Unit 110V	<div style="border: 1px solid black; border-radius: 10px; padding: 10px;"> <p>REF 20-8020-110-01 SN 123123</p> <p>EN 110V Robotic Unit</p> <p>FR Unité robotique 110 V</p> <p>IT Unità robotica 110 V</p> <p>DE Roboterbasis, 110 V</p> <p>ES Unidad robótica de 110 V</p> <p style="text-align: right; font-size: small;">LBB-20-8020-110-01 rev C</p> </div>
Robotic Unit 220V	<div style="border: 1px solid black; border-radius: 10px; padding: 10px;"> <p>REF 20-8020-110-26 SN 123123</p> <p>EN 220V Robotic Unit</p> <p>FR Unité robotique 220 V</p> <p>IT Unità robotica 220 V</p> <p>DE Roboterbasis, 220 V</p> <p>ES Unidad robótica de 220 V</p> <p style="text-align: right; font-size: small;">LBB-20-8020-110-26 rev C</p> </div>
Robotic Unit 100V	<div style="border: 1px solid black; border-radius: 10px; padding: 10px;"> <p>REF 20-8020-110-17 SN 123123</p> <p>EN 100V Robotic Unit</p> <p>FR Unité robotique 100 V</p> <p>IT Unità robotica 100 V</p> <p>DE Roboterbasis, 100 V</p> <p>ES Unidad robótica de 100 V</p> <p style="text-align: right; font-size: small;">LBB-20-8020-110-17 rev C</p> </div>
Optical Unit	<div style="border: 1px solid black; border-radius: 10px; padding: 10px;"> <p>REF 20-8020-120-01 SN 123123</p> <p>EN Recon Platform Optical Unit Optical Unit</p> <p>FR Unité optique Recon Platform Station optique</p> <p>IT Unità ottica piattaforma di ricostruzione Unità ottica</p> <p>DE Recon-Plattform optische Einheit Optikeinheit</p> <p>ES Unidad óptica de la plataforma Recon Unidad óptica</p> <p style="text-align: right; font-size: small;">LBB-20-8020-120-01 rev B</p> </div>











15.1.2 Symbols on the Labels

Label	Symbol title	Description
	General warning sign	Indicates a general warning
	Refer to instruction manual/ booklet	Indicates that the instruction manual/booklet must be read
 IFUs, Patents & Symbol Glossary http://labeling.zimmerbiomet.com	Consult electronic instructions for use	Indicates the need for the user to consult the instructions for use available online at the website mentioned below the graphic
	Power supply specifications	Power supply specifications for concerned countries (ex: Germany, France) IPX0: No protection against liquids
	Power supply specifications	Power supply specifications for concerned countries (ex: U.S., Canada) IPX0: No protection against liquids
	Power supply specifications	Power supply specifications for concerned countries (Japan) IPX0: No protection against liquids
	Type BF applied part	BF type device. Indicates a higher degree of protection against electric shock. This medical device is floating and does not have connections with ground. It meets the patient leakage current requirements
	Magnetic Resonance (MR) Unsafe	Indicates a medical device that poses unacceptable risks to the patient, medical staff or other persons within a Magnetic Resonance environment. MR Unsafe: Keep away from Magnetic Resonance Imaging (MRI) equipment
	Prescription Only	Indicates that Federal law restricts this device to sale by or on the order of a physician
	European market authorization	Indicates that the product conforms to EU Medical Device Regulation
	Curtis-Straus NRTL/SCC Certification Mark	Indicates that Bureau Veritas/Curtis-Straus nationally recognized testing laboratories mark, with "US" and "C" identifiers, for U.S. & Canada for NRTL/SCC certification
	Unique Device Identifier	Indicates a carrier that contains unique device identifier information







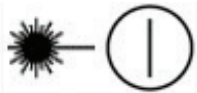

15.1.2 Symbols on the Labels (cont.)

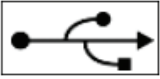
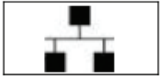
Label	Symbol title	Description
	Regulatory Compliance Mark (RCM) for Australia and New Zealand.	Indicates that the medical device complies with the requirements of the electrical and EMC regulations of Australia and New Zealand Regulatory Compliance Mark (RCM) for Australia and New Zealand
	Non-sterile	Indicates a medical device that has not been subjected to a sterilization process
	Manufacturer	Indicates the medical device manufacturer
	Date of manufacture	Indicates the date when the medical device was manufactured
	Authorized representative in the European Community/ European Union	Indicates the authorized representative in the European Community/European Community
	Importer	Indicates the entity importing the medical device into the locale
	Catalogue number	Indicates the manufacturer's catalogue number so that the medical device can be identified
	Serial number	Indicates the manufacturer's serial number so that a specific medical device can be identified
	Kg Device Weight	Indicates device weight in kilogram(s)
	Recycle: Electronic Equipment	Indicates that the equipment should not be discarded as unsorted waste but must be sent to separate collection facilities for recovery and recycling
	Medical Device	Indicates the item is a medical device
	Batch code	Indicates the manufacturer's batch code so that the batch or lot can be identified
	Contains hazardous substances	Indicates a medical device that contains substances that can be carcinogenic, mutagenic, reprotoxic (CMR), or substances with endocrine disrupting properties

15.1.3 Other Symbols on the Device

Label	Symbol title	Description
	Bottom of Robotic Unit Rear Panel	OFF – Switch off the device
	Bottom of Robotic Unit Rear Panel	ON – Switch on the device
	Bottom of Robotic Unit Rear Panel	Central unit RESTART button
	Bottom of Robotic Unit Rear Panel	Foot Pedal socket
	Bottom of Robotic Unit Rear Panel	Socket for black RJ45 cable of Optical Unit wiring
	Bottom of Robotic Unit Rear Panel	Socket for white RJ45 cable of Optical Unit wiring
	Bottom of Robotic Unit Rear Panel	Socket for Optical Unit main cord
	Bottom of Robotic Unit Rear Panel	Controller servicing port (deactivated)
	Bottom of Robotic Unit Rear Panel	Robotic Unit immobilization system move lever up/down to unlock/lock
	Bottom cover of Robotic Unit, above stabilization feet	Risk of foot crushing
	Middle of Robotic Unit Rear Panel	Distance sensor on/off symbol Not applicable for Knee application (deactivated)

15.1.3 Other Symbols on the Device (cont.)

Label	Location	Description
	Camera handle on Optical Unit	Optical sensor laser pointer ON/OFF symbol. OFF is a stable position, while the ON position only remains during the time the button is depressed
	Middle of Robotic Unit Rear Panel	USB port
	Middle of Robotic Unit Rear Panel	Ethernet port symbol. Not applicable for Knee application (deactivated)
	Middle of Robotic Unit Rear Panel	Do not use USB ports for charging a cell phone. Connection for USB drive, keyboard and mouse only
	Middle of Robotic Unit Rear Panel	Do not use USB ports for connecting a wireless device. Connection for USB drive, keyboard and mouse only
	Top cover of Robotic Unit	Emergency stop
	Rear of Touchscreen on Robotic Unit	Stored energy hazard
	Optical Unit	Lock Optical Unit in place using the brake on all four wheels
	Optical Unit	Fold the camera arm for transportation
	Rear of camera on the right	Laser beam – Never look directly at the laser beam – Class II laser
		

15.2 Technical Specifications

15.2.1 Environmental Specifications

Environment	Storage and Transportation	Operating
Temperature	0°C to 50°Celsius	15°C to 35°Celsius
Humidity	8% to 93% (without condensation)	8% to 75% (without condensation)
Air pressure	800 hPa to 1060 hPa	800 hPa to 1060 hPa



In the presence of an HVAC system, ensure that the Robotic Unit or Optical Stand is not positioned in the way of the expelled airflow, as it can influence the stability of the camera readings.

15.2.2 Device Performance

Device performance	Value
Robotic Arm positioning accuracy	< 0.75 mm RMS

15.2.3 Device Dimensions

The device has the following exterior dimensions in millimeters:

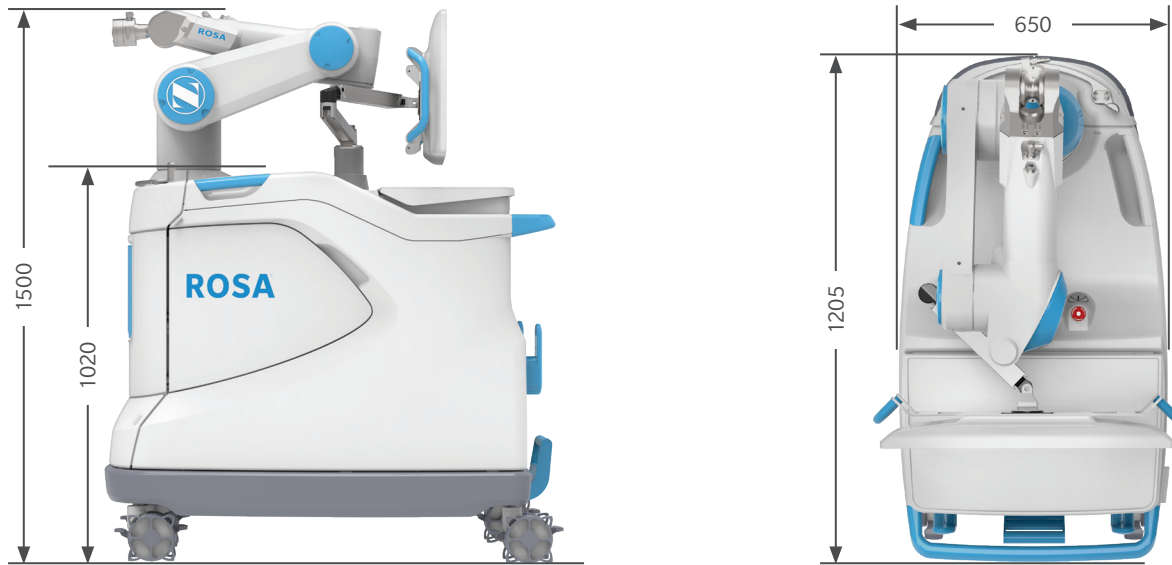

Robotic Unit Dimensions

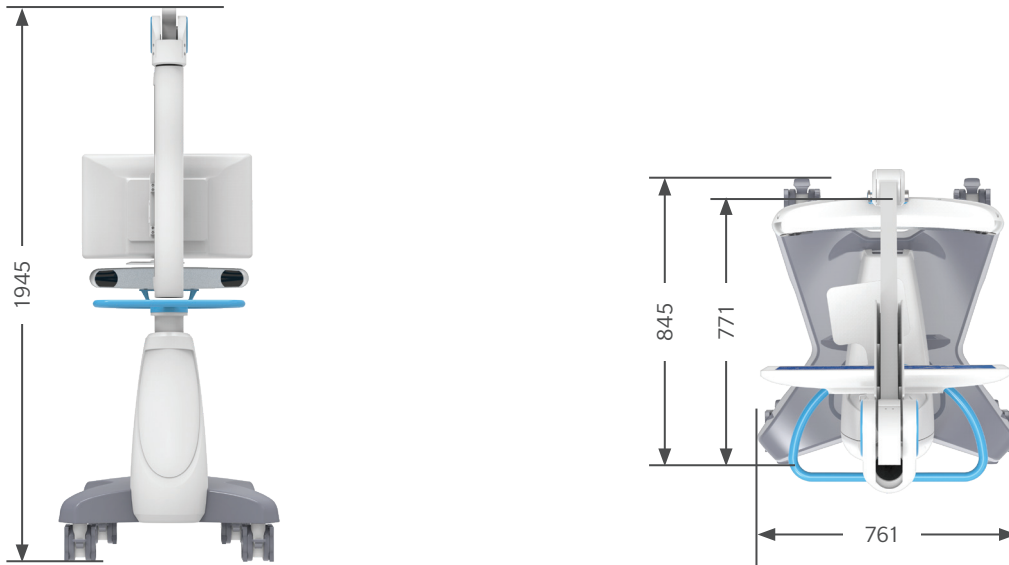

Optical Unit Dimensions

Robotic Unit weight: Approximately 320kg (705 lb)

Optical Unit weight: Approximately 140 kg (309 lb)

15.2.4 Robotic Arm Working Range

ROSA Knee is equipped with a Stäubli 6-axis Robotic Arm and has 6° of freedom.

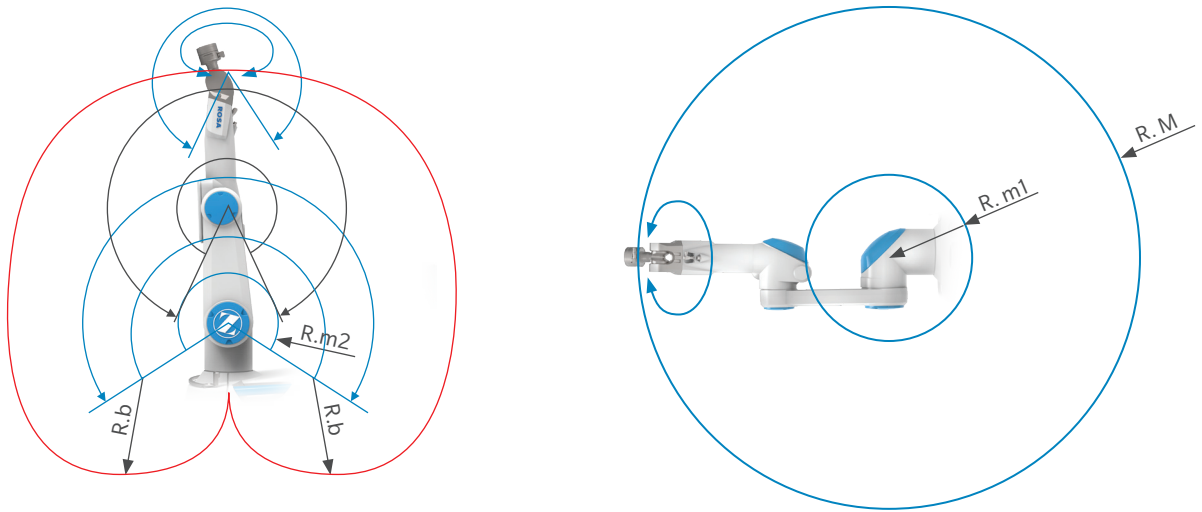

Robotic Arm Working Range

Dimension	Value
Maximum radius between joint 1 and 5 (R.M)	850 mm
Minimum radius between joint 1 and 5 (R.m1)	209 mm
Minimum radius between joint 2 and 4 (R.m2)	208 mm
Minimum radius between joint 3 and 5 (R.b)	450 mm

15.3 Safety Classification & Standards

Type	Classification
Protection against electric shock	Class 1 Patient protection = type BF applied part
Protection against ingress of fluids	Robotic Unit = IPX0 Optical Unit = IPX0 Footswitch = IP68
Protection against laser beam	Navigation camera = Class 2

15.3 Safety Classification & Standards (cont.)

Standard	Description
IEC 60601-1	Medical electrical equipment – Part 1: General requirements for basic safety and essential performances
IEC 60601-1-2	Medical electrical equipment – Part 1-2: General requirements for basic safety and essential performances – Collateral Standard: Electromagnetic Compatibility
IEC 60601-1-6	Medical devices – Part 1-6: General requirement for basic safety and essential performance – Usability
IEC 62366-1	Medical devices – Part 1: Application of usability engineering to medical devices
ISO 17664	Sterilization of medical devices – Information to be provided by the manufacturer for the processing of resterilizable medical devices
ISO 17665-1	Sterilization of healthcare products – Moist heat-Part 1: Requirements for the development, validation and routine control of a sterilization process for medical devices
ISO 10993-1	Biological evaluation of medical devices – Part 1: Evaluation and testing within a risk management process
IEC 62304	Medical device software – Software life cycle process
IEC 60825-1	Safety of laser products – Part 1: Equipment classification and requirements

15.3.1 Cable Lengths

Cable and Accessories	Maximum Length	Type of Test	In Accordance With
Power Cable Foot Pedal Cable	>3m >3m	RF Emissions	CISPR, Class A
		Harmonic current	IEC 61000-3-2
		Voltage fluctuations/flicker	IEC 61000-3-3
Optical Unit main cord Force Sensor Cable	>3m <3m	Electrostatic discharge immunity	IEC 61000-4-2
		Radiated immunity – electromagnetic fields	IEC 61000-4-3
		Electrical fast transient/ burst immunity test	IEC 61000-4-4
		Surge immunity test	IEC 61000-4-5
		Conducted immunity – Conducted RF	IEC 61000-4-6
		Radiated immunity – Magnetic field	The electromagnetic field strengths of fixed radio frequency transmitters
		Downtimes, dips and variation of the power supply voltage	

15.4 Electromagnetic Compatibility

All the information below is based on the normative requirements to which the manufacturers of Electrical Medical devices are subjected to, in regards with IEC60601-1-2. The medical device complies with applicable electromagnetic compatibility standards, however, the user will ensure that any electromagnetic interference does not create an additional hazard, such as radio frequency transmitters or other electronic devices. In this section, you will find information necessary to ensure the installation and commissioning of your medical device under the best conditions in terms of electromagnetic compatibility.

The different cords of the medical device must be separated from each other. Certain types of mobile telecommunication devices, such as mobile phones, are likely to interfere with the medical device. The separation distances recommended in this chapter must therefore be strictly observed. The medical device must not be used near or on another device. If this cannot be avoided, it must be checked for proper operation under the conditions of use before use. The use of accessories other than those specified or sold by Zimmer CAS as replacement parts, may result in an increase in the emission or a reduction of the immunity of the medical device.

15.4.1 Electromagnetic (EM) Emissions

The device has been designed for use in an electromagnetic environment as specified below. The user must ensure that it operates in this type of environment.

Emission trials	Conformity	Electromagnetic Environment - Guide
RF emissions CISPR 11 ⁽¹⁾	Group 1	The ROSA Recon Platform is part of CISPR11 group 1. The ROSA Recon Platform uses RF energy as below: Wi-Fi in the 2.4 GHz band (2400 to 2483,5MHz) or in the 5.0GHz band (5150 to 5250MHz; 5250 to 5350MHz and 5470 to 5725MHz) as a means of radio communication (5GHz band being restricted to indoor use only). Emission powers in the 2.4GHz band do not exceed 19.92dBm, compliant with ETSI EN 300 328. Emission powers in the 5.0GHz band do not exceed 22.97dBm, compliant with ETSI EN 301 893. The device uses 2 dipole antennas.
RF emissions CISPR 11 ⁽¹⁾	Class A	This equipment has been tested and found to comply with the limits for a Class A digital device, pursuant to part 15 of the FCC Rules. These limits are designed to provide reasonable protection against harmful interference when the equipment is operated in a commercial environment. This equipment generates, uses, and can radiate radio frequency energy and, if not installed and used in accordance with the instruction manual, may cause harmful interference to radio communications. Operation of this equipment in a residential area is likely to cause harmful interference in which case the user will be required to correct the interference at his own expense.

⁽¹⁾The emission characteristics of this device make it suitable for use in industrial areas and hospitals (class A defined in CISPR 11). When used in a residential environment (for which class B defined in CISPR 11 is normally required), this device may not provide adequate protection for radio frequency communications services. The user may need to take mitigation measures, such as relocating or reorienting of the device.

Ensuring that the system operates in the above environment will maintain basic safety and essential performance with regard to electromagnetic disturbances for the expected service life.

See System information in the case management application for FCC identifier.

15.4.1 Electromagnetic (EM) Emissions (cont.)



BE	LU	NL	FR	DE
IT	DK	IE	UK	EL
ES	PT	AT	FI	SE
CY	EE	HU	LV	LT
MT	PL	SI	SK	CZ
BG	RO	HR		
NO	CH	IS	LI	

Reference	Performance Specification	If Lost or Degraded due to EM Disturbances
Essential Performance 1	Accurate information display	Information display not accurate
Essential Performance 2	Accurate robot positioning	Robot positioning not accurate
Basic Safety 1	Collision detection	Collision detection feature affected
Basic Safety 2	No unwanted robot motion	Unwanted robot motion could occur

Using the ROSA Knee System with other products or components unless such other products or components are expressly recognized as compatible with the system could affect basic safety and essential performance in terms of EM disturbances.

15.4.2 Electromagnetic and Magnetic Immunity

The device has been designed for use in an electromagnetic environment, such as specified below. The user must ensure that it operates in this type of environment.

Electromagnetic Immunity

ROSA Knee is intended for use in a professional healthcare facility environment. The user of ROSA Knee should ensure that it is used in such an environment.

Immunity Test	IEC 60601-1-2 Test Level	Compliance Level of ROSA Knee	Electromagnetic Environment Guide
Electrostatic discharge (ESD) EN 61000-4-2	±8 kV contact (direct, indirect horizontal, indirect vertical) ±2 kV, ±4 kV, ±8 kV, ±15 kV air	±8 kV contact ±2 kV, ±4 kV, ±8 kV, ±15 kV air	Main power quality should be that of a professional healthcare facility environment

15.4.2 Electromagnetic and Magnetic Immunity (cont.)

Immunity Test	IEC 60601-1-2 Test Level	Compliance Level of ROSA Knee	Electromagnetic Environment Guide
Electrical fast transient/burst Signal input/output parts PORT (L> 3m) IEC 61000-4-4	± 1 kV/100 Hz	± 1 kV/100 Hz	Main power quality should be that of a professional healthcare facility environment
Electrical fast transient/burst Input a.c power PORT IEC 61000-4-4	± 2 kV/ 100 Hz	± 2 kV/ 100 Hz	
Surge Input a.c power PORT IEC 61000-4-5	$\pm 0,5$ kV, ± 1 kV line to line $\pm 0,5$ kV, ± 1 kV, ± 2 kV line to ground	$\pm 0,5$ kV, ± 1 kV line to line $\pm 0,5$ kV, ± 1 kV, ± 2 kV line to ground	Main power quality should be that of a professional healthcare facility environment
Voltage dips Input a.c power PORT EN 61000-4-11	0% U_T for 0.5 cycles At 0°, 45°, 90°, 135°, 180°, 225°, 270° and 315° 0% U_T for 1 cycles and 70% U_T for 25\30 cycles (500ms) Single phase: at 0°	0% U_T for 0,5 cycle at 0°, 45°, 90°, 135°, 180°, 225°, 270° and 315° <5% U_T (>95% dip in U_T) for 0,5 cycle 0% U_T for 1 cycle and 70% U_T for 25/30 cycles (500ms) Single phase: at 0°	Main power quality should be that of a professional healthcare facility environment. If the user of device requires continued operation during power outages, it is recommended that the device be powered from an uninterruptible power supply or a battery
Voltage interruptions EN 61000-4-11	0 % U_T For 250\300 cycles	0 % U_T For 250\300 cycles	
RATED power frequency (50\60 Hz) magnetic field Enclosure port IEC61000-4-8	30 A/m ^a 50 Hz and 60 Hz	30 A/m ^a 50 Hz and 60 Hz	Power frequency magnetic fields should be at levels characteristic of a professional healthcare facility environment

Note: U_T is the a.c. main voltage prior to application of the test level.

^a Using a minimum distance of 15 cm between the ROSA Knee device and source of power frequency magnetic field.

15.4.3 Electromagnetic Immunity and Portable and Mobile Radio Frequency (RF) Communication Equipment

Electromagnetic Immunity Conducted and Radiated RF

ROSA Knee is intended for use in a professional healthcare facility environment. The user of ROSA Knee should assure that it is used in such an environment.

Immunity Test	IEC 60601 Test Level	Compliance Level of ROSA Knee	Electromagnetic Environment Guide
Conducted disturbances induced by RF fields Signal input/output parts PORT (L > 0m) IEC 61000-4-6	3 V 150 kHz to 80 MHz 6V in ISM ^d band and band between 0.15MHz and 80MHz including amateur radio band 80% MA at 1KHz	3 V 150 kHz to 80 MHz 6V in ISM ^d band and band between 0.15MHz and 80MHz including amateur radio band 80% MA at 1KHz	Main power quality should be that of a professional healthcare facility environment Warning: Portable and mobile RF communications equipment (including peripherals, such as antenna cables and external antennas) should be used no closer than 30 cm (12 inches) to any part of the ROSA Knee device, including cables specified by the manufacturer Otherwise, degradation of the performance of this equipment could result
Conducted disturbances induced by RF fields input a.c power PORT IEC 61000-4-6	3 V 150 kHz to 80 MHz 6V in ISM ^d band and band between 0.15MHz and 80MHz including amateur radio band 80% MA at 1KHz	3 V 150 kHz to 80 MHz 6V in ISM ^d band and band between 0.15MHz and 80MHz including amateur radio band 80% MA at 1KHz	
Radiated RF electromagnetic field IMMUNITY Enclosure port IEC 61000-4-3	3 V/m 80 MHz to 2.7 GHz 80% AM at 1 kHz	3 V/m 80 MHz to 2.7 GHz 80% AM at 1 kHz	
IMMUNITY to proximity fields from RF wireless communications equipment Enclosure port IEC 61000-4-3	385MHz/ 27V/m 450 MHz/ 28V/m 710 MHz/ 9V/m 745 MHz/ 9V/m 780 MHz/ 9V/m 810 MHz/ 28V/m 870 MHz/ 28V/m 930 MHz/ 28V/m 1720 MHz/ 28V/m 1845 MHz/ 28V/m 1970 MHz/ 28V/m 2450 MHz/ 28V/m 5240 MHz/ 9V/m 5500 MHz/ 9V/m 5785 MHz/ 9V/m	385 MHz/ 27V/m 450 MHz/ 28V/m 710 MHz/ 9V/m 745 MHz/ 9V/m 780 MHz/ 9V/m 810 MHz/ 28V/m 870 MHz/ 28V/m 930 MHz/ 28V/m 1720 MHz/ 28V/m 1845 MHz/ 28V/m 1970 MHz/ 28V/m 2450 MHz/ 28V/m 5240 MHz/ 9V/m 5500 MHz/ 9V/m 5785 MHz/ 9V/m	

^dThe ISM (Industrial Scientific and Medical) bands between 150 kHz and 80 MHz are 6.765 MHz to 6.795 MHz; 13.553 MHz to 13.567 MHz; 26.957 MHz to 27.283 MHz; and 40.66 MHz to 40.70 MHz.

15.4.4 Recommended Separation Distances

The ROSA Knee device is intended for use in an electromagnetic environment in which radiated RF disturbances are controlled. The user or installer of the medical device can help to avoid electromagnetic interference by maintaining a minimum distance, depending on the maximum power of the radio frequency transmission equipment. RF portable communications equipment (including peripherals such as antenna cables and external antennas) should not be used closer than 30 cm (12 inches) to any part of the ROSA Knee device, including the cables specified by the manufacturer. Otherwise, the performance of these devices may be impaired.

16. Software Licenses

16.1 Boost

Boost Software License - Version 1.0 - August 17th, 2003

Permission is hereby granted, free of charge, to any person or organization obtaining a copy of the software and accompanying documentation covered by this license (the "Software") to use, reproduce, display, distribute, execute, and transmit the Software, and to prepare derivative works of the Software, and to permit third-parties to whom the Software is furnished to do so, all subject to the following:

The copyright notices in the Software and this entire statement, including the above license grant, this restriction and the following disclaimer, must be included in all copies of the Software, in whole or in part, and all derivative works of the Software, unless such copies or derivative works are solely in the form of machine-executable object code generated by a source language processor.

THE SOFTWARE IS PROVIDED "AS IS", WITHOUT WARRANTY OF ANY KIND, EXPRESS OR IMPLIED, INCLUDING BUT NOT LIMITED TO THE WARRANTIES OF MERCHANTABILITY, FITNESS FOR A PARTICULAR PURPOSE, TITLE AND NON-INFRINGEMENT. IN NO EVENT SHALL THE COPYRIGHT HOLDERS OR ANYONE DISTRIBUTING THE SOFTWARE BE LIABLE FOR ANY DAMAGES OR OTHER LIABILITY, WHETHER IN CONTRACT, TORT OR OTHERWISE, ARISING FROM, OUT OF OR IN CONNECTION WITH THE SOFTWARE OR THE USE OR OTHER DEALINGS IN THE SOFTWARE

16.2 VTK

Copyright (c) 2008-Present Ken Martin, Will Schroeder, Bill Lorensen

All rights reserved.

Redistribution and use in source and binary forms, with or without modification, are permitted provided that the following conditions are met:

- Redistributions of source code must retain the above copyright notice, this list of conditions and the following disclaimer.
- Redistributions in binary form must reproduce the above copyright notice, this list of conditions and the following disclaimer in the documentation and/or other materials provided with the distribution.
- Neither name of Ken Martin, Will Schroeder, or Bill Lorensen nor the names of any contributors may be used to endorse or promote products derived from this software without specific prior written permission.

THIS SOFTWARE IS PROVIDED BY THE COPYRIGHT HOLDERS AND CONTRIBUTORS "AS IS" AND ANY EXPRESS OR IMPLIED WARRANTIES, INCLUDING, BUT NOT LIMITED TO, THE IMPLIED WARRANTIES OF MERCHANTABILITY AND FITNESS FOR A PARTICULAR PURPOSE ARE DISCLAIMED. IN NO EVENT SHALL THE AUTHORS OR CONTRIBUTORS BE LIABLE FOR ANY DIRECT, INDIRECT, INCIDENTAL, SPECIAL, EXEMPLARY, OR CONSEQUENTIAL DAMAGES (INCLUDING, BUT NOT LIMITED TO, PROCUREMENT OF SUBSTITUTE GOODS OR SERVICES; LOSS OF USE, DATA, OR PROFITS; OR BUSINESS INTERRUPTION) HOWEVER CAUSED AND ON ANY THEORY OF LIABILITY, WHETHER IN CONTRACT, STRICT LIABILITY, OR TORT (INCLUDING NEGLIGENCE OR OTHERWISE) ARISING IN ANY WAY OUT OF THE USE OF THIS SOFTWARE, EVEN IF ADVISED OF THE POSSIBILITY OF SUCH DAMAGE.

16.3 GDCM

Program: GDCM (Grassroots DICOM). A DICOM library

Copyright (c) 2006-2016 Mathieu Malaterre

Copyright (c) 1993-2005 CREATIS

(CREATIS = Centre de Recherche et d'Applications en Traitement de l'Image)

All rights reserved.

Redistribution and use in source and binary forms, with or without modification, are permitted provided that the following conditions are met:

- Redistributions of source code must retain the above copyright notice, this list of conditions and the following disclaimer.
- Redistributions in binary form must reproduce the above copyright notice, this list of conditions and the following disclaimer in the documentation and/or other materials provided with the distribution.
- Neither name of Mathieu Malaterre, or CREATIS, nor the names of any contributors (CNRS, INSERM, UCB, Universite Lyon I), may be used to endorse or promote products derived from this software without specific prior written permission.

THIS SOFTWARE IS PROVIDED BY THE COPYRIGHT HOLDERS AND CONTRIBUTORS "AS IS" AND ANY EXPRESS OR IMPLIED WARRANTIES, INCLUDING, BUT NOT LIMITED TO, THE IMPLIED WARRANTIES OF MERCHANTABILITY AND FITNESS FOR A PARTICULAR PURPOSE ARE DISCLAIMED. IN NO EVENT SHALL THE AUTHORS OR CONTRIBUTORS BE LIABLE FOR ANY DIRECT, INDIRECT, INCIDENTAL, SPECIAL, EXEMPLARY, OR CONSEQUENTIAL DAMAGES (INCLUDING, BUT NOT LIMITED TO, PROCUREMENT OF SUBSTITUTE GOODS OR SERVICES; LOSS OF USE, DATA, OR PROFITS; OR BUSINESS INTERRUPTION) HOWEVER CAUSED AND ON ANY THEORY OF LIABILITY, WHETHER IN CONTRACT, STRICT LIABILITY, OR TORT (INCLUDING NEGLIGENCE OR OTHERWISE) ARISING IN ANY WAY OUT OF THE USE OF THIS SOFTWARE, EVEN IF ADVISED OF THE POSSIBILITY OF SUCH DAMAGE.

16.4 ITK

TERMS AND CONDITIONS FOR USE, REPRODUCTION, AND DISTRIBUTION

1. Definitions.

"License" shall mean the terms and conditions for use, reproduction, and distribution as defined by Sections 1 through 9 of this document.

"Licensor" shall mean the copyright owner or entity authorized by the copyright owner that is granting the License.

Legal Entity shall mean the union of the acting entity and all other entities that control, are controlled by, or are under common control with that entity. For the purposes of this definition,

control means (i) the power, direct or indirect, to cause the direction or management of such entity, whether by contract or otherwise, or (ii) ownership of fifty percent (50%) or more of the outstanding shares, or (iii) beneficial ownership of such entity.

"You" (or "Your") shall mean an individual or Legal Entity exercising permissions granted by this License.

"Source" form shall mean the preferred form for making modifications, including but not limited to software source code, documentation, and configuration files.

"Object" form shall mean any form resulting from mechanical transformation or translation of a Source form, including but not limited to compiled object code, generated documentation, and conversions to other media types.

"Work" shall mean the work of authorship, whether in Source or Object form, made available under the License, as indicated by a copyright notice that is included in or attached to the work (an example is provided in the Appendix below).

16.4 ITK (cont.)

“Derivative” Works shall mean any work, whether in Source or Object form, that is based on (or derived from) the Work and for which the editorial revisions, annotations, elaborations, or other modifications represent, as a whole, an original work of authorship. For the purposes of this License, Derivative Works shall not include works that remain separable from, or merely link (or bind by name) to the interfaces of, the Work and Derivative Works thereof.

“Contribution” shall mean any work of authorship, including the original version of the Work and any modifications or additions to that Work or Derivative Works thereof, that is intentionally submitted to Licensor for inclusion in the Work by the copyright owner or by an individual or Legal Entity authorized to submit on behalf of the copyright owner. For the purposes of this definition, submitted means any form of electronic, verbal, or written communication sent to the Licensor or its representatives, including but not limited to communication on electronic mailing lists, source code control systems, and issue tracking systems that are managed by, or on behalf of, the Licensor for the purpose of discussing and improving the Work, but excluding communication that is conspicuously marked or otherwise in writing by the copyright owner as Not a Contribution.

“Contributor” shall mean Licensor and any individual or Legal Entity on behalf of whom a Contribution has been received by Licensor and subsequently incorporated within the Work.

2. Grant of Copyright License. Subject to the terms and conditions of this License, each Contributor hereby grants to You a perpetual, worldwide, non-exclusive, no-charge, royalty-free, irrevocable copyright license to reproduce, prepare Derivative Works of, publicly display, publicly perform, sublicense, and distribute the Work and such Derivative Works in Source or Object form.

3. Grant of Patent License. Subject to the terms and conditions of this License, each Contributor hereby grants to You a perpetual, worldwide, non-exclusive, no-charge, royalty-free, irrevocable (except as stated in this section) patent license to make, have made, use, offer to sell, sell, import, and otherwise transfer the Work, where such license applies only to those patent claims licensable by such Contributor that are necessarily infringed by their Contribution(s) alone or by combination of their Contribution(s) with the Work to which such Contribution(s) was submitted. If You institute patent litigation against any entity (including a cross-claim or counterclaim in a lawsuit) alleging that the Work or a Contribution incorporated within the Work constitutes direct contributory patent infringement, then any patent licenses granted to You under this License for that Work shall terminate as of the date such litigation is filed.

4. Redistribution. You may reproduce and distribute copies of the or Derivative Works thereof in any medium, with or without modifications, and in Source or Object form, provided that You meet the following conditions:

(a) You must give any other recipients of the Work or Derivative Works a copy of this License; and

(b) You must cause any modified files to carry prominent notices stating that You changed the files; and

(c) You must retain, in the Source form of any Derivative Works that You distribute, all copyright, patent, trademark, and attribution notices from the Source form of the Work, excluding those notices that do not pertain to any part of the Derivative Works; and

(d) If the Work includes a NOTICE text file as part of its distribution, then any Derivative Works that You distribute must include a readable copy of the attribution notices contained within such NOTICE file, excluding those notices that do not pertain to any part of the Derivative Works, in at least one of the following places: within a NOTICE text file distributed as part of the Derivative Works; within the Source form or documentation, if provided along with the Derivative Works; or, within a display generated by the Derivative Works, if and wherever such third-party notices normally appear. The contents of the NOTICE file are for informational purposes only and do not modify the License. You may add Your own attribution notices within Derivative Works that You distribute, alongside or as an addendum to the NOTICE text from the Work, provided that such additional attribution notices cannot be construed as modifying the License.

You may add Your own copyright statement to Your modifications and may provide additional or different license terms and conditions for use, reproduction, or distribution of Your modifications, or for any such Derivative Works as a whole, provided Your use, reproduction, and distribution of the Work otherwise complies with the conditions stated in this License.

16.4 ITK (cont.)

5. Submission of Contributions. Unless You explicitly state otherwise, any Contribution intentionally submitted for inclusion in the Work by You to the Licensor shall be under the terms and conditions of this License, without any additional terms or conditions. Notwithstanding the above, nothing herein shall supersede or modify the terms of any separate license agreement you may have executed with Licensor regarding such Contributions.

6. Trademarks. This License does not grant permission to use the trade names, trademarks, service marks, or product names of the Licensor, except as required for reasonable and customary use in describing the origin of the Work and reproducing the content of the NOTICE file.

7. Disclaimer of Warranty. Unless required by applicable law or agreed to in writing, Licensor provides the Work (and each Contributor provides its Contributions) on an “AS IS” BASIS, WITHOUT WARRANTIES OR CONDITIONS OF ANY KIND, either express or implied, including, without limitation, any warranties or conditions of TITLE, NON-INFRINGEMENT, MERCHANTABILITY, or FITNESS FOR A PARTICULAR PURPOSE. You are solely responsible for determining the appropriateness of using or redistributing the Work and assume any risks associated with Your exercise of permissions under this License.

8. Limitation of Liability. In no event and under no legal theory, whether in tort (including negligence), contract, or otherwise, unless required by applicable law (such as deliberate and grossly negligent acts) or agreed to in writing, shall any Contributor be liable to You for damages, including any direct, indirect, special, incidental, or consequential damages of any character arising as a result of this License or out of the use or inability to use the Work (including but not limited to damages for loss of goodwill, work stoppage, computer failure or malfunction, or any and all other commercial damages or losses), even if such Contributor has been advised of the possibility of such damages.

9. Accepting Warranty or Additional Liability. While redistributing the Work or Derivative Works thereof, You may choose to offer, and charge a fee for, acceptance of support, warranty, indemnity, or other liability obligations and/or rights consistent with this License. However, in accepting such obligations, You may act only on Your own behalf and on Your sole responsibility, not on behalf of any other Contributor, and only if You agree to indemnify, defend, and hold each Contributor harmless for any liability incurred by, or claims asserted against, such Contributor by reason of your accepting any such warranty or additional liability.”

16.5 Open SSL

TERMS AND CONDITIONS FOR USE, REPRODUCTION, AND DISTRIBUTION

1. Definitions.

“License” shall mean the terms and conditions for use, reproduction, and distribution as defined by Sections 1 through 9 of this document.

“Licensor” shall mean the copyright owner or entity authorized by the copyright owner that is granting the License.

“Legal Entity” shall mean the union of the acting entity and all other entities that control, are controlled by, or are under common control with that entity. For the purposes of this definition, “control” means (i) the power, direct or indirect, to cause the direction or management of such entity, whether by contract or otherwise, or (ii) ownership of fifty percent (50%) or more of the outstanding shares, or (iii) beneficial ownership of such entity.

“You” (or “Your”) shall mean an individual or Legal Entity exercising permissions granted by this License.

“Source” form shall mean the preferred form for making modifications, including but not limited to software source code, documentation source, and configuration files.

“Object” form shall mean any form resulting from mechanical transformation or translation of a Source form, including but not limited to compiled object code, generated documentation, and conversions to other media types.

“Work” shall mean the work of authorship, whether in Source or Object form, made available under the License, as indicated by a copyright notice that is included in or attached to the work (an example is provided in the Appendix below).

16.5 Open SSL (cont.)

“Derivative Works” shall mean any work, whether in Source or Object form, that is based on (or derived from) the Work and for which the editorial revisions, annotations, elaborations, or other modifications represent, as a whole, an original work of authorship. For the purposes of this License, Derivative Works shall not include works that remain separable from, or merely link (or bind by name) to the interfaces of, the Work and Derivative Works thereof.

“Contribution” shall mean any work of authorship, including the original version of the Work and any modifications or additions to that Work or Derivative Works thereof, that is intentionally submitted to Licensor for inclusion in the Work by the copyright owner or by an individual or Legal Entity authorized to submit on behalf of the copyright owner. For the purposes of this definition, “submitted” means any form of electronic, verbal, or written communication sent to the Licensor or its representatives, including but not limited to communication on electronic mailing lists, source code control systems, and issue tracking systems that are managed by, or on behalf of, the Licensor for the purpose of discussing and improving the Work, but excluding communication that is conspicuously marked or otherwise designated in writing by the copyright owner as “Not a Contribution.”

“Contributor” shall mean Licensor and any individual or Legal Entity on behalf of whom a Contribution has been received by Licensor and subsequently incorporated within the Work.

2. Grant of Copyright License. Subject to the terms and conditions of this License, each Contributor hereby grants to You a perpetual, worldwide, non-exclusive, no-charge, royalty-free, irrevocable copyright license to reproduce, prepare Derivative Works of, publicly display, publicly perform, sublicense, and distribute the Work and such Derivative Works in Source or Object form.

3. Grant of Patent License. Subject to the terms and conditions of this License, each Contributor hereby grants to You a perpetual, worldwide, non-exclusive, no-charge, royalty-free, irrevocable (except as stated in this section) patent license to make, have made, use, offer to sell, sell, import, and otherwise transfer the Work, where such license applies only to those patent claims licensable by such Contributor that are necessarily infringed by their Contribution(s) alone or by combination of their Contribution(s) with the Work to which such Contribution(s) was submitted. If You institute patent litigation against any entity (including a cross-claim or counterclaim in a lawsuit) alleging that the Work or a Contribution incorporated within the Work constitutes direct or contributory patent infringement, then any patent licenses granted to You under this License for that Work shall terminate as of the date such litigation is filed.

4. Redistribution. You may reproduce and distribute copies of the Work or Derivative Works thereof in any medium, with or without modifications, and in Source or Object form, provided that You meet the following conditions:

- (a) You must give any other recipients of the Work or Derivative Works a copy of this License; and
- (b) You must cause any modified files to carry prominent notices stating that You changed the files; and
- (c) You must retain, in the Source form of any Derivative Work that You distribute, all copyright, patent, trademark, and attribution notices from the Source form of the Work, excluding those notices that do not pertain to any part of the Derivative Works; and
- (d) If the Work includes a “NOTICE” text file as part of its distribution, then any Derivative Works that You distribute must include a readable copy of the attribution notices contained within such NOTICE file, excluding those notices that do not pertain to any part of the Derivative Works, in at least one of the following places: within a NOTICE text file distributed as part of the Derivative Works; within the Source form or documentation, if provided along with the Derivative Works; or, within a display generated by the Derivative Works, if and wherever such third-party notices normally appear. The contents of the NOTICE file are for informational purposes only and do not modify the License. You may add Your own attribution notices within Derivative Works that You distribute, alongside or as an addendum to the NOTICE text from the Work, provided that such additional attribution notices cannot be construed as modifying the License.

You may add Your own copyright statement to Your modifications and may provide additional or different license terms and conditions for use, reproduction, or distribution of Your modifications, or for any such Derivative Works as a whole, provided Your use, reproduction, and distribution of the Work otherwise complies with the conditions stated in this License.

16.5 Open SSL (cont.)

5. Submission of Contributions. Unless You explicitly state otherwise, any Contribution intentionally submitted for inclusion in the Work by You to the Licensor shall be under the terms and conditions of this License, without any additional terms or conditions. Notwithstanding the above, nothing herein shall supersede or modify the terms of any separate license agreement you may have executed with Licensor regarding such Contributions.

6. Trademarks. This License does not grant permission to use the trade names, trademarks, service marks, or product names of the Licensor, except as required for reasonable and customary use in describing the origin of the Work and reproducing the content of the NOTICE file.

7. Disclaimer of Warranty. Unless required by applicable law or agreed to in writing, Licensor provides the Work (and each Contributor provides its Contributions) on an “AS IS” BASIS, WITHOUT WARRANTIES OR CONDITIONS OF ANY KIND, either express or implied, including, without limitation, any warranties or conditions of TITLE, NON-INFRINGEMENT, MERCHANTABILITY, or FITNESS FOR A PARTICULAR PURPOSE. You are solely responsible for determining the appropriateness of using or redistributing the Work and assume any risks associated with Your exercise of permissions under this License.

8. Limitation of Liability. In no event and under no legal theory, whether in tort (including negligence), contract, or otherwise, unless required by applicable law (such as deliberate and grossly negligent acts) or agreed to in writing, shall any Contributor be liable to You for damages, including any direct, indirect, special, incidental, or consequential damages of any character arising as a result of this License or out of the use or inability to use the Work (including but not limited to damages for loss of goodwill, work stoppage, computer failure or malfunction, or any and all other commercial damages or losses), even if such Contributor has been advised of the possibility of such damages.

9. Accepting Warranty or Additional Liability. While redistributing the Work or Derivative Works thereof, You may choose to offer, and charge a fee for, acceptance of support, warranty, indemnity, or other liability obligations and/or rights consistent with this License. However, in accepting such obligations, You may act only on Your own behalf and on Your sole responsibility, not on behalf of any other Contributor, and only if You agree to indemnify, defend, and hold each Contributor harmless for any liability incurred by, or claims asserted against, such Contributor by reason of your accepting any such warranty or additional liability.

16.6 JSON

Copyright (c) 2013-2025 Niels Lohmann

Permission is hereby granted, free of charge, to any person obtaining a copy of this software and associated documentation files (the “Software”), to deal in the Software without restriction, including without limitation the rights to use, copy, modify, merge, publish, distribute, sublicense, and/or sell copies of the Software, and to permit persons to whom the Software is furnished to do so, subject to the following conditions:

The above copyright notice and this permission notice shall be included in all copies or substantial portions of the Software.

THE SOFTWARE IS PROVIDED “AS IS”, WITHOUT WARRANTY OF ANY KIND, EXPRESS OR IMPLIED, INCLUDING BUT NOT LIMITED TO THE WARRANTIES OF MERCHANTABILITY, FITNESS FOR A PARTICULAR PURPOSE AND NON-INFRINGEMENT. IN NO EVENT SHALL THE AUTHORS OR COPYRIGHT HOLDERS BE LIABLE FOR ANY CLAIM, DAMAGES OR OTHER LIABILITY, WHETHER IN AN ACTION OF CONTRACT, TORT OR OTHERWISE, ARISING FROM, OUT OF OR IN CONNECTION WITH THE SOFTWARE OR THE USE OR OTHER DEALINGS IN THE SOFTWARE.

16.7 Eigen

Mozilla Public License Version 2.0

1. Definitions

- 1.1 “Contributor”
means each individual or legal entity that creates, contributes to the creation of, or owns Covered Software.
- 1.2 “Contributor Version”
means the combination of the Contributions of others (if any) used by a Contributor and that particular Contributor’s Contribution.

16.7 Eigen (cont.)

- 1.3 Contribution” means Covered Software of a particular Contributor.
“Covered Software” means Source Code Form to which the initial Contributor has attached the notice in Exhibit
- 1.4 A, the Executable Form of such Source Code Form, and Modifications of such Source Code Form, in each case including portions thereof.
“Incompatible With Secondary Licenses” means
- 1.5 (a) that the initial Contributor has attached the notice described in Exhibit B to the Covered Software; or
(b) that the Covered Software was made available under the terms of version 1.1 or earlier of the License, but not also under the terms of a Secondary License.
- 1.6 “Executable Form” means any form of the work other than Source Code Form.
- 1.7 “Larger Work” means a work that combines Covered Software with other material, in a separate file or files, that is not Covered Software.
- 1.8 “License” means this document.
- 1.9 “Licensable” means having the right to grant, to the maximum extent possible, whether at the time of the initial grant or subsequently, any and all of the rights conveyed by this License.
“Modifications” means any of the following:
- 1.10 (a) any file in Source Code Form that results from an addition to, deletion from, or modification of the contents of Covered Software; or
(b) any new file in Source Code Form that contains any Covered Software.
“Patent Claims” of a Contributor
- 1.11 means any patent claim(s), including without limitation, method, process, and apparatus claims, in any patent Licensable by such Contributor that would be infringed, but for the grant of the License, by the making, using, selling, offering for sale, having made, import, or transfer of either its Contributions or its Contributor Version.
- 1.12 “Secondary License” means either the GNU General Public License, Version 2.0, the GNU Lesser General Public License, Version 2.1, the GNU Affero General Public License, Version 3.0, or any later versions of those licenses.
- 1.13 “Source Code Form” means the form of the work preferred for making modifications.
“You” (or “Your”) means an individual or a legal entity exercising rights under this License. For legal entities, “You” includes any entity that controls, is controlled by, or is under common control with You. For purposes of this
- 1.14 definition, “control” means (a) the power, direct or indirect, to cause the direction or management of such entity, whether by contract or otherwise, or (b) ownership of more than fifty percent (50%) of the outstanding shares or beneficial ownership of such entity.

2. License Grants and Conditions

- Grants Each Contributor hereby grants You a world-wide, royalty-free, non-exclusive license:
- 2.1 (a) under intellectual property rights (other than patent or trademark) Licensable by such Contributor to use, reproduce, make available, modify, display, perform, distribute, and otherwise exploit its Contributions, either on an unmodified basis, with Modifications, or as part of a Larger Work; and
(b) under Patent Claims of such Contributor to make, use, sell, offer for sale, have made, import, and otherwise transfer either its Contributions or its Contributor Version.
- Effective Date
- 2.2 The licenses granted in Section 2.1 with respect to any Contribution become effective for each Contribution on the date the Contributor first distributes such Contribution.

16.7 Eigen (cont.)

Limitations on Grant Scope

The licenses granted in this Section 2 are the only rights granted under this License. No additional rights or licenses will be implied from the distribution or licensing of Covered Software under this License. Notwithstanding Section 2.1(b) above, no patent license is granted by a Contributor:

- 2.3 (a) for any code that a Contributor has removed from Covered Software; or
- (b) for infringements caused by: (i) Your and any other third party's modifications of Covered Software, or (ii) the combination of its Contributions with other software (except as part of its Contributor Version); or
- (c) under Patent Claims infringed by Covered Software in the absence of its Contributions. This License does not grant any rights in the trademarks, service marks, or logos of any Contributor (except as may be necessary to comply with the notice requirements in Section 3.4).

Subsequent Licenses

- 2.4 No Contributor makes additional grants as a result of Your choice to distribute the Covered Software under a subsequent version of this License (see Section 10.2) or under the terms of a Secondary License (if permitted under the terms of Section 3.3).

Representation

- 2.5 Each Contributor represents that the Contributor believes its Contributions are its original creation(s) or it has sufficient rights to grant the rights to its Contributions conveyed by this License.

Fair Use

- 2.6 This License is not intended to limit any rights You have under applicable copyright doctrines of fair use, fair dealing, or other equivalents.

Conditions

- 2.7 Sections 3.1, 3.2, 3.3, and 3.4 are conditions of the licenses granted in Section 2.1.

3. Responsibilities

Distribution of Source Form

- 3.1 All distribution of Covered Software in Source Code Form, including any Modifications that You create or to which You contribute, must be under the terms of this License. You must inform recipients that the Source Code Form of the Covered Software is governed by the terms of this License, and how they can obtain a copy of this License. You may not attempt to alter or restrict the recipients' rights in the Source Code Form.

Distribution of Executable Form

If You distribute Covered Software in Executable Form then:

- 3.2 (a) such Covered Software must also be made available in Source Code Form, as described in Section 3.1, and You must inform recipients of the Executable Form how they can obtain a copy of such Source Code Form by reasonable means in a timely manner, at a charge no more than the cost of distribution to the recipient; and
- (b) You may distribute such Executable Form under the terms of this License, or sublicense it under different terms, provided that the license for the Executable Form does not attempt to limit or alter the recipients' rights in the Source Code Form under this License.

Distribution of a Larger Work

- 3.3 You may create and distribute a Larger Work under terms of Your choice, provided that You also comply with the requirements of this License for the Covered Software. If the Larger Work is a combination of Covered Software with a work governed by one or more Secondary Licenses, and the Covered Software is not Incompatible With Secondary Licenses, this License permits You to additionally distribute such Covered Software under the terms of such Secondary License(s), so that the recipient of the Larger Work may, at their option, further distribute the Covered Software under the terms of either this License or such Secondary License(s).

Notices

- 3.4 You may not remove or alter the substance of any license notices (including copyright notices, patent notices, disclaimers of warranty, or limitations of liability) contained within the Source Code Form of the Covered Software, except that You may alter any license notices to the extent required to remedy known factual inaccuracies.

16.7 Eigen (cont.)

Application of Additional Terms

You may choose to offer, and to charge a fee for, warranty, support, indemnity or liability obligations to one or more recipients of Covered Software. However, You may do so only on Your own behalf, and not on behalf of any

- 3.5 Contributor. You must make it absolutely clear that any such warranty, support, indemnity, or liability obligation is offered by You alone, and You hereby agree to indemnify every Contributor for any liability incurred by such Contributor as a result of warranty, support, indemnity or liability terms You offer. You may include additional disclaimers of warranty and limitations of liability specific to any jurisdiction.

4. Inability to Comply Due to Statute or Regulation

If it is impossible for You to comply with any of the terms of this License with respect to some or all of the Covered Software due to statute, judicial order, or regulation then You must: (a) comply with the terms of this License to the maximum extent possible; and (b) describe the limitations and the code they affect. Such description must be placed in a text file included with all distributions of the Covered Software under this License. Except to the extent prohibited by statute or regulation, such description must be sufficiently detailed for a recipient of ordinary skill to be able to understand it.

5. Termination

The rights granted under this License will terminate automatically if You fail to comply with any of its terms.

However, if You become compliant, then the rights granted under this License from a particular Contributor are reinstated (a) provisionally, unless and until such Contributor explicitly and finally terminates Your grants, and (b) on an ongoing basis, if such Contributor fails to notify You of then on-compliance by some reasonable means prior to 60 days after You have come back into compliance. Moreover, Your grants from a particular Contributor are reinstated on an ongoing basis if such Contributor notifies You of the non-compliance by some reasonable means, this is the first time You have received notice of non-compliance with this License from such Contributor, and You become compliant prior to 30 days after Your receipt of the notice.

5.1

If You initiate litigation against any entity by asserting a patent infringement claim (excluding declaratory judgment actions, counter-claims, and cross-claims) alleging that a Contributor Version directly or indirectly infringes any patent, then the rights granted to You by any and all Contributors for the Covered Software under Section 2.1 of this License shall terminate.

5.2

In the event of termination under Sections 5.1 or 5.2 above, all end user license agreements (excluding distributors and resellers) which have been validly granted by You or Your distributors under this License prior to termination shall survive termination.

5.3

6. Disclaimer of Warranty

Covered Software is provided under this License on an “as is” basis, without warranty of any kind, either expressed, implied, or statutory, including, without limitation, warranties that the Covered Software is free of defects, merchantable, fit for a particular purpose or non-infringing. The entire risk as to the quality and performance of the Covered Software is with You. Should any Covered Software prove defective in any respect, You (not any Contributor) assume the cost of any necessary servicing, repair, or correction. This disclaimer of warranty constitutes an essential part of this License. No use of any Covered Software is authorized under this License except under this disclaimer.

7. Limitation of Liability

Under no circumstances and under no legal theory, whether tort (including negligence), contract, or otherwise, shall any Contributor, or anyone who distributes Covered Software as permitted above, be liable to You for any direct, indirect, special, incidental, or consequential damages of any character including, without limitation, damages for lost profits, loss of goodwill, work stoppage, computer failure or malfunction, or any and all other commercial damages or losses, even if such party shall have been informed of the possibility of such damages. This limitation of liability shall not apply to liability for death or personal injury resulting from such party’s negligence to the extent applicable law prohibits such limitation. Some jurisdictions do not allow the exclusion or limitation of incidental or consequential damages, so this exclusion and limitation may not apply to You.

16.7 Eigen (cont.)

7. Limitation of Liability

Under no circumstances and under no legal theory, whether tort (including negligence), contract, or otherwise, shall any Contributor, or anyone who distributes Covered Software as permitted above, be liable to You for any direct, indirect, special, incidental, or consequential damages of any character including, without limitation, damages for lost profits, loss of goodwill, work stoppage, computer failure or malfunction, or any and all other commercial damages or losses, even if such party shall have been informed of the possibility of such damages. This limitation of liability shall not apply to liability for death or personal injury resulting from such party's negligence to the extent applicable law prohibits such limitation. Some jurisdictions do not allow the exclusion or limitation of incidental or consequential damages, so this exclusion and limitation may not apply to You.

8. Litigation

Any litigation relating to this License may be brought only in the courts of a jurisdiction where the defendant maintains its principal place of business and such litigation shall be governed by laws of that jurisdiction, without reference to its conflict-of-law provisions. Nothing in this Section shall prevent a party's ability to bring cross-claims or counter-claims.

9. Miscellaneous

This License represents the complete agreement concerning the subject matter hereof. If any provision of this License is held to be unenforceable, such provision shall be reformed only to the extent necessary to make it enforceable. Any law or regulation which provides that the language of a contract shall be construed against the drafter shall not be used to construe this License against a Contributor.

10. Versions of the License

New Versions

- 10.1 Mozilla Foundation is the license steward. Except as provided in Section 10.3, no one other than the license steward has the right to modify or publish new versions of this License. Each version will be given a distinguishing version number.

Effect of New Versions

- 10.2 You may distribute the Covered Software under the terms of the version of the License under which You originally received the Covered Software, or under the terms of any subsequent version published by the license steward.

Modified Versions

- 10.3 If you create software not governed by this License, and you want to create a new license for such software, you may create and use a modified version of this License if you rename the license and remove any references to the name of the license steward (except to note that such modified license differs from this License).

Distributing Source Code Form that is Incompatible With Secondary Licenses

If You choose to distribute Source Code Form that is Incompatible With Secondary Licenses under the terms of this version of the License, the notice described in Exhibit B of this License must be attached.

- 10.4 Exhibit A - Source Code Form License Notice

This Source Code Form is subject to the terms of the Mozilla Public License, v. 2.0. If a copy of the MPL was not distributed with this file, You can obtain one at <http://mozilla.org/MPL/2.0/>. If it is not possible or desirable to put the notice in a particular file, then You may include the notice in a location (such as a LICENSE file in a relevant directory) where a recipient would be likely to look for such a notice. You may add additional accurate notices of copyright ownership.

Exhibit B - "Incompatible With Secondary Licenses" Notice

This Source Code Form is "Incompatible With Secondary Licenses", as defined by the Mozilla Public License, v. 2.0.

APPENDIX A: Supported Implants and A/P Referencing of the ROSA Knee System



Verify regional availability of implants prior to selection in the Implant Editor (including sizing).

Femoral Implants		
Persona®	NexGen®	Vanguard®
<ul style="list-style-type: none"> - CR Standard - CR Narrow - PS Standard - PS Narrow 	<ul style="list-style-type: none"> - CR Option - CR Porous - CR Precoat - CR Flex Option - CR Flex Porous - CR Flex Precoat - CR Flex Gender Porous - CR Flex Gender Precoat - LPS Option - LPS Porous - LPS Precoat - LPS Flex Option - LPS Flex Porous - LPS Flex Precoat - LPS Flex TiV - LPS Flex Gender - LPS Flex Gender Porous 	<ul style="list-style-type: none"> - CR - PS
Tibial Implants		
Persona	NexGen	Vanguard
<ul style="list-style-type: none"> - Cemented Stemmed Tibia - Trabecular Metal Tibia - Cemented Keel Tibia - OsseoTi® Keel Tibia 	<ul style="list-style-type: none"> - 7° Option Fluted - CR Precoat Pegged - MIS Precoat Stemmed - Option Stemmed - Precoat Stemmed - TM Modular 	<ul style="list-style-type: none"> - Cruciate Finned - I Beam - Regenerex®
Bearing		
Persona	NexGen	Vanguard
<ul style="list-style-type: none"> - Cruciate Retaining (CR) Bearing - Medial Congruent® (MC) Bearing - Ultracongruent (UC) Bearing - Posterior Stabilized (PS) Bearing - Constrained Posterior Stabilized (CPS) Bearing. <p>Refer to implant Surgical Technique for bearing compatibility with implants</p>	Refer to NexGen Surgical Technique	Refer to Vanguard Surgical Technique
Instrumentation's AP Referencing		
Persona	NexGen	Vanguard
<ul style="list-style-type: none"> - Anterior Referencing - Posterior Referencing 	<ul style="list-style-type: none"> - Legacy - PRI (only for Flex implants) 	<ul style="list-style-type: none"> - Posterior Referencing

APPENDIX A: Supported Implants and A/P Referencing of the ROSA Knee System (cont.)

The system has controls to set the femur implant's size, within the following options:

a) For Persona family:

Brand	Size
CR Standard	3, 4, 5, 6, 7, 8, 9, 10, 11, 12
CR Narrow	3, 4, 5, 6, 7, 8, 9, 10, 11
PS Standard	3, 4, 5, 6, 7, 8, 9, 10, 11, 12
PS Narrow	3, 4, 5, 6, 7, 8, 9, 10, 11

b) For NexGen family:

Brand	Size	Brand	Size
CR Option	C, D, E, F, G	LPS Option	A, B, C, D, E, F, G, H
CR Porous	C, D, E, F, G, H	LPS Precoat	B, C, D, E, F, G
CR Precoat	C, D, E, F, G, H	LPS Porous	B, C, D, E, F, G
CR Flex Option	B, C-, C, D-, D, E-, E, F-, F, G-, G	LPS Flex Option	C, D, E, F, G
CR Flex Porous	C-, C, D-, D, E-, E, F-, F, G-, G	LPS Flex Porous	B, C, D, E, F, G
CR Flex Precoat	C-, C, D-, D, E-, E, F-, F, G-, G	LPS Flex Precoat	A, B, C, D, E, F, G, H
CR Flex Gender Porous	C-, C, D-, D, E-, E, F-, F, G-, G	LPS Flex TiV	C, D, E, F, G
CR Flex Gender Precoat	C-, C, D-, D, E-, E, F-, F, G-, G	LPS Flex Gender	C, D, E, F, G
		LPS Flex Gender Porous	C, D, E, F, G

c) For Vanguard family:

Brand	Size
CR	55, 57.5, 60, 62.5, 65, 67.5, 70, 72.5, 75, 80
PS	55, 57.5, 60, 62.5, 65, 67.5, 70, 72.5, 75, 80

The system has controls to set the tibial implant's size, within the following options:

a) For Persona family:

Brand	Size
Cemented Stemmed Tibia	C, D, E, F, G, H, J
Trabecular Metal Tibia	C, D, E, F, G, H, J
Cemented Keel Tibia	C, D, E, F, G, H, J
OsseoTi Keel Tibia	C, D, E, F, G, H, J

APPENDIX A: Supported Implants and A/P Referencing of the ROSA Knee System (cont.)

b) For NexGen family:

Brand	Size
7° Option Fluted	1, 2, 3, 4, 5, 6, 7, 8, 9, 10
CR Precoat Pegged	1, 2, 3, 4, 5, 6, 7, 8, 9, 10
MIS Precoat Stemmed	1, 2, 3, 4, 5, 6, 7, 8, 9, 10
Option Stemmed	3, 4, 5, 6, 7, 8
Precoat Stemmed	1, 2, 3, 4, 5, 6, 7, 8, 9, 10
TM Modular	2, 3, 4, 5, 6, 7, 8

c) For Vanguard family:

Brand	Size
Cruciate Finned	59, 63, 67, 71, 75, 79, 83, 87, 91
I Beam	59, 63, 67, 71, 75, 79, 83, 87, 91
Regenerex	59, 63, 67, 71, 75, 79, 83, 87

The system has controls to set the polyethylene's thickness, within the following options:

Brand	Brand	Size	Thickness (mm)
NexGen	CR	1-2, 3-4, 5-6, 7-10	10, 12, 14, 17, 20
NexGen	LPS	1-2, 3-4, 5-6, 7-10	10, 12, 14, 17, 20, 23
Persona	CR	CD, EF, GH, J	10, 11, 12, 13, 14, 16, 18
Persona	PS	CD, EF, GH, J	10, 11, 12, 13, 14, 16, 18, 20
Vanguard	CR	59, 63/67, 71/75, 79/83, 87/91	10, 11, 12, 13, 14, 16, 18
Vanguard	PS	59, 63/67, 71/75, 79/83, 87/91	10, 11, 12, 13, 14, 16, 18, 20

The polyethylene's family is the same as the implant family.

The polyethylene's brand is the same as the femur implant's brand.

The polyethylene's size is the same as the tibial implant's size.

APPENDIX B: Implant Compatibility Between Femoral and Tibial Component Brands

a) For Persona family: All implant brands are compatible

b) For NexGen family:

Tibia: NexGen Brand	Femur: NexGen Brand			
	CR	CR Flex	LPS	LPS Flex
7° Option Fluted	X	X	X	X
CR Precoat Pegged	X			
MIS Modular Precoat Stemmed	X	X	X	X
Option Stemmed	X	X	X	X
Precoat Stemmed	X	X	X	X
TM Modular	X	X	X	X

c) For Vanguard family: All implant brands are compatible

APPENDIX C: Implant Compatibility Between Femoral and Tibial Component Sizes

a) For Persona CR femoral implants:

		Persona CR Femoral Size									
		3	4	5	6	7	8	9	10	11	12
Persona Tibial Size	C	X	X	X	X	X	X	X			
	D	X	X	X	X	X	X	X			
	E	X	X	X	X	X	X	X	X	X	
	F	X	X	X	X	X	X	X	X	X	
	G					X	X	X	X	X	X
	H					X	X	X	X	X	X
	J							X	X	X	X

APPENDIX C: Implant Compatibility Between Femoral and Tibial Component Sizes (cont.)

Refer to implant-specific Surgical Technique for bearing compatibility.

b) For Persona PS femoral implants:

		Persona PS Femoral Size									
		3	4	5	6	7	8	9	10	11	12
Persona Tibial Size	C	X	X	X	X	X	X	X			
	D	X	X	X	X	X	X	X			
	E	X	X	X	X	X	X	X	X	X	
	F	X	X	X	X	X	X	X	X	X	
	G				X	X	X	X	X	X	X
	H				X	X	X	X	X	X	X
	J								X	X	X

c) For NexGen CR femoral implants:

		NexGen CR Femoral Size							
		A	B	C-/C	D-/D	E-/E	F-/F	G-/G	H-/H
NexGen Tibial Size	1-2	X	X	X	X	X	X	X	X
	3-4	X	X	X	X	X	X	X	X
	5-6	X	X	X	X	X	X	X	X
	7-10			X	X	X	X	X	X

d) For NexGen LPS femoral implants:

		NexGen LPS Femoral Size							
		A	B	C	D	E	F	G	H
NexGen Tibial Size	1-2	X	X	X	X				
	3-4	X	X	X	X	X	X		
	5-6			X	X	X	X	X	X
	7-10					X	X	X	X

e) For Vanguard implants: All sizes are compatible.



Please visit ZimmerBiomet.com/ROSAKnee for additional information.

De Mayo Knee Positioner® is a trademark of Innovative Medical Products, Inc.

For Persona IQ: The kinematic data from this device have not been demonstrated to have clinical benefit. It is not intended to be utilized for clinical decision-making, and no data have been evaluated by FDA regarding clinical benefits.

All content herein is protected by copyright, trademarks and other intellectual property rights, as applicable, owned by or licensed to Zimmer Biomet or its affiliates unless otherwise indicated, and must not be redistributed, duplicated or disclosed, in whole or in part, without the express written consent of Zimmer Biomet.

This material is intended for health care professionals. Distribution to any other recipient is prohibited.

For additional indications, contraindications, warnings, precautions, potential adverse effects and patient counseling information, see the Instructions for Use or contact your local representative; visit www.zimmerbiomet.com for additional product information.

Check for country product clearance and reference product specific instructions for use. Persona IQ is only available in the United States. Consult your sales representative if needed.

Zimmer Biomet does not practice medicine. This technique was developed in conjunction with health care professionals. This document is intended for surgeons and is not intended for laypersons. Each surgeon should exercise his or her own independent judgment in the diagnosis and treatment of an individual patient, and this information does not purport to replace the comprehensive training surgeons have received.

As with all surgical procedures, the technique used in each case will depend on the surgeon's medical judgment as the best treatment for each patient. Results will vary based on health, weight, activity and other variables. Not all patients are candidates for this product and/or procedure.

Caution: Federal (USA) law restricts this device to sale by or on the order of a surgeon. Rx only.

©2021, 2022, 2023, 2024, 2025, 2026 Zimmer Biomet



2300.19-GLBL-en-Issue Date-2026-05



Legal Manufacturer

Zimmer CAS
75 Queen Street Suite 3300
Montreal (Quebec) H3C 2N6
Canada
Tel +1-866-3D-ORTHO
or 514-396-5422

zimmerbiomet.com



CE mark is only valid if it's also on the product label



IFUs, Patents &
Symbol Glossary

<http://labeling.zimmerbiomet.com>