

HAMMR[®] Automated Impaction System

Surgical Technique



Table of Contents

Device Description, Indications and Contraindications	3
Handpiece Operation - Adapter Assembly	4
Handpiece Operation - Impact Direction Control	5
Handpiece Operation - Energy Control	5
Acetabular Shell Insertion	6
Liner Impaction	8
Femoral Canal Preparation	9
Femoral Implant Impaction	9
Femoral Head Impaction	10

Device Description

The HAMMR automated impaction system consists of a battery-operated handpiece and adapters. The system delivers impacts to instruments and implants similar to a manual mallet.

Indications

The HAMMR automated impaction system is indicated for Total Hip Arthroplasty (THA) procedures in the preparation of bone, implantation of acetabular cup and femoral stem implants.

Contraindications

The HAMMR automated impaction system is contraindicated for use with the size 7 Echo® Bi-Metric® Full Length High Offset stem.

System Compatibility

HAMMR is compatible with the following Zimmer Biomet implant systems:

- Z1™ Femoral Hip System
- G7® Acetabular System
- Avenir Complete® Hip System
- Taperloc® Complete Hip System
- Echo® Bi-Metric® Full Length and Microplasty® Hip Stem (contraindicated for use with the size 7 Echo® Bi-Metric® Full Length High Offset stem)

	LOCKED	UNLOCKED
VIEW FROM THE TOP	■ — ■	■ — ●
VIEW FROM THE BOTTOM	● — ●	● — ■
STATUS		

When the symbols match, the chuck is locked. When the symbols do not match, the chuck is unlocked.

Table 1

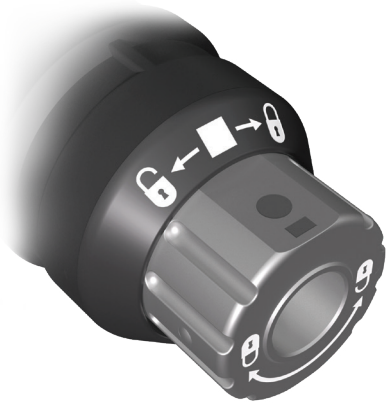

Figure 1



Figure 2

Handpiece Operation - Adapter Assembly

The HAMMR handpiece interfaces with implants and instruments through the use of various adapters.

The adapters connect to the handpiece chuck mechanism. The chuck will accept an adapter when unlocked.

The chuck is unlocked by rotating the chuck knob counter-clockwise (as shown on the front face of the chuck) until the square and circle symbols do not match (Table 1, Figure 1).

The chuck is locked by rotating the chuck knob clockwise (as shown on the front face of the chuck) until the square and circle symbols match (Table 1, Figure 2).

Note: Figure 1 and 2 show the view from the top of the chuck. Refer to Table 1 for view from the bottom.

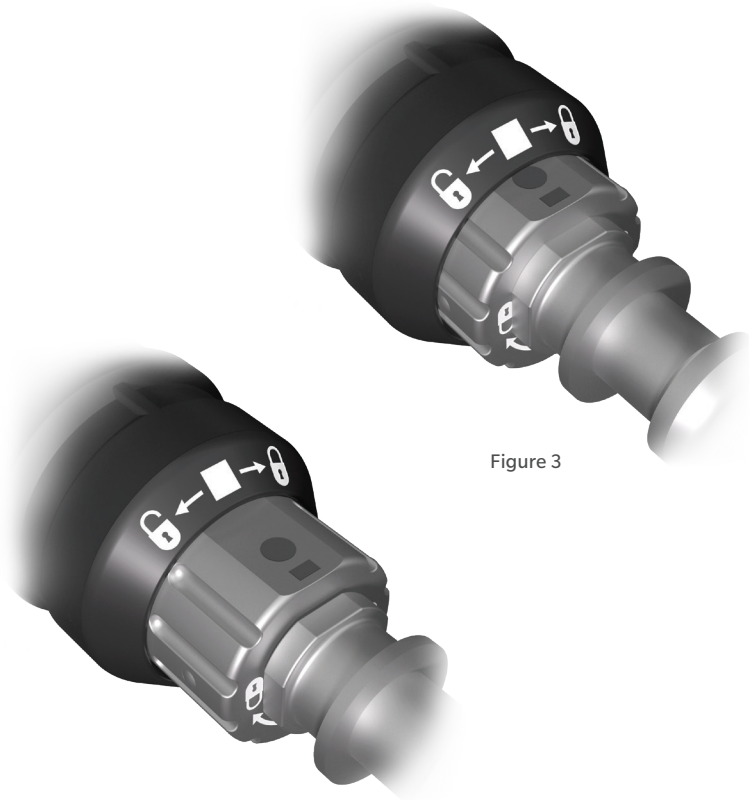

Figure 3



Figure 4



Figure 5

Handpiece Operation - Impact Direction Control

The HAMMR handpiece delivers forward and reverse impacts.

Forward impacts are initiated by pushing on the handpiece to compress the chuck (Figure 3) then pulling the trigger.

Reverse impacts are initiated by pulling on the handpiece to extend the chuck (Figure 4) then pulling the trigger.

Note: Do not dry fire the HAMMR handpiece (pulling the trigger without initiating forward or reverse direction) as this can damage the unit.

Handpiece Operation - Energy control

The HAMMR power system delivers various levels of energy.

The energy selector “0” (zero) position is a safe mode that prevents the handpiece from delivering forward or reverse impacts. The handpiece should be kept in the safe mode while not in use or while attaching or removing adapters and instrumentation to the device (Figure 5).

The “1”, “2”, “3” positions enable Low, Medium and High forward impacts, respectively. Reverse impacts are always at the same level regardless of the energy setting.



Figure 6

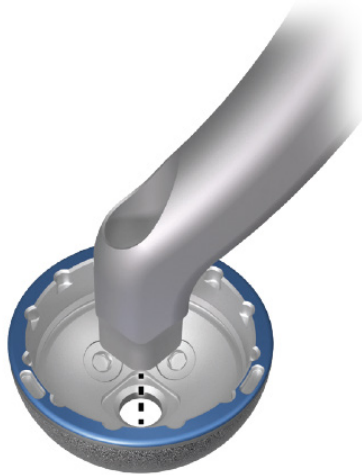

Figure 7

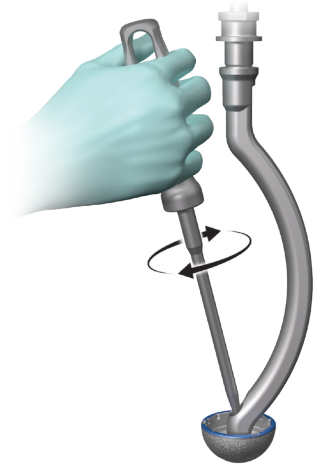

Figure 8

Acetabular Shell Insertion

The curved modular or straight modular adapter can be used to insert the provisional shell or the shell implant.

Modular Shell Insertion Adapter Assembly

When using the curved or straight modular adapter, assemble the modular bolt with the threaded distal end of the adapter (Figure 6) by turning the bolt clockwise using the the G7 ball hex driver.

Align the square tip of the modular adapter with the square feature in the shell (Figure 7). Secure the modular adapter to the shell firmly by turning the modular bolt clockwise using the ball hex driver (Figure 8).

ⓘ **Note:** It is recommended to align the window in the modular inserters with the hole pattern on the limited hole shells for easier access to the modular screw after insertion (Figure 7).

ⓘ **Note:** Ensure the shell is securely fastened to the insertion adapter by lightly pulling on the shell.



Figure 9



Figure 10



Figure 11

Acetabular Shell Insertion (cont.)

Optional Positioning Guides

The HAMMR shell insertion adapters are compatible with the Zimmer Biomet G7 Acetabular System lateral and anterior supine positioning guides (Figure 9).

ⓘ **Note:** Further instructions for use of the positioning guides are provided in the G7 Acetabular System Surgical Technique.

Acetabular Shell Impaction

Ensure the HAMMR handpiece is in safe mode (energy selector set to the zero position) and attach the shell insertion adapter to the handpiece (Figure 10).

Switch the HAMMR energy setting from zero to low (setting 1) and begin impacting the shell. Advance the selector switch to setting 2 or 3 as needed to fully seat the shell.

Optional Strike Plate Impactions

If additional manual impactions are desired to further seat the shell, the manual strike plate must be placed over the attachment feature of the shell insertion adapter to prevent damage to the adapter (Figure 11).

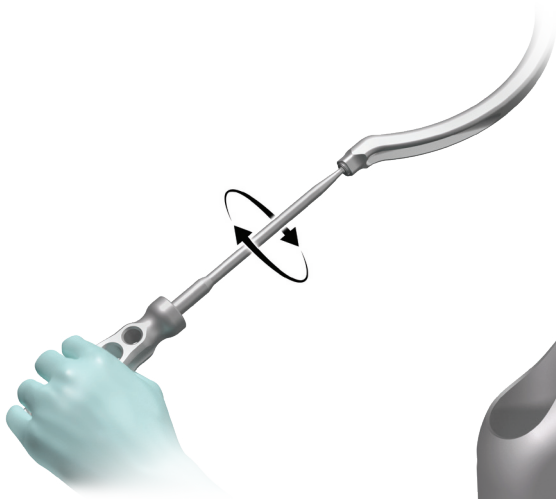

Figure 12

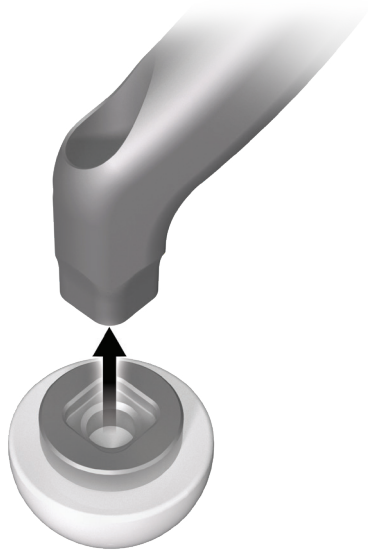

Figure 13

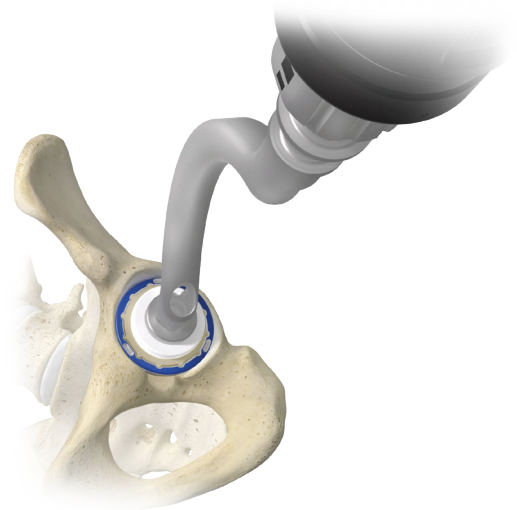

Figure 14

Acetabular Shell Insertion (cont.)

Modular Shell Insertion Adapter Disassembly

To disassemble for cleaning, place a 3.5 mm hex screwdriver in the tip of the threaded modular bolt. Turn the screwdriver clockwise while pushing lightly to disengage the threaded bolt from the shaft (Figure 12).

Liner Impaction

Ensure the HAMMR handpiece is in safe mode and thread the appropriately-sized G7 liner impactor onto the end of the shell insertion adapter (Figure 13). Place the tip of the impactor on the dome of the liner with the handle perpendicular to the face of the shell (Figure 14).

Switch the HAMMR power setting from the zero setting to the low setting and begin impacting the liner. Impact the liner and advance the selector switch to setting 2 or 3 as needed until the liner is fully seated.

ⓘ **Note:** Further instructions for liner assembly and seating are provided in the G7 Acetabular System Surgical Technique.

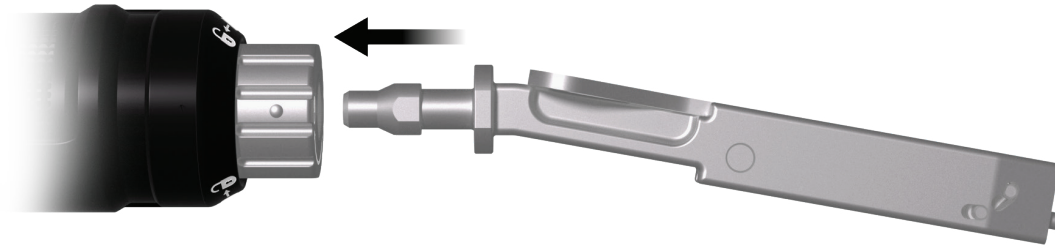

Figure 15

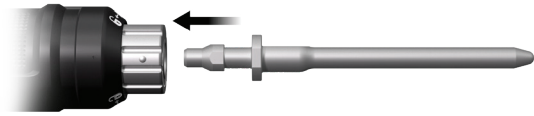

Figure 16

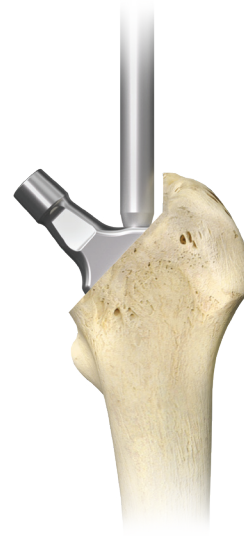

Figure 17

Femoral Canal Preparation

Ensure the HAMMR handpiece is in safe mode (energy selector set to the zero position) and attach the broach impaction adapter to the handpiece.

Attach the broach using the lever on the broach adapter (Figure 15). Switch the HAMMR energy setting from zero to low (setting 1). Broach in a sequential fashion pushing forward to apply forward impacts and pulling back to apply extraction impacts.

- ⓘ **Note:** Zimmer Biomet offers specific broach impaction adapters for different surgical approaches.
- ⓘ **Note:** Always set the handpiece energy selector back to safe mode (zero) while exchanging broaches.
- ⓘ **Note:** Further instructions for femoral canal preparation are provided in the Avenir Complete Hip System, Taperloc Complete Hip System or Echo Bi-Metric Hip System Surgical Technique depending on which product is being used.

Femoral Implant Impaction

Ensure the HAMMR handpiece is in safe mode (energy selector set to the zero position) and attach the stem driver adapter to the handpiece (Figure 16).

Switch the HAMMR energy setting from zero to low (setting 1) and impact the femoral stem implant into the canal until it is fully seated (Figure 17).

- ⓘ **Note:** Further instructions for femoral stem implantation are provided in the Avenir Complete Hip System, Taperloc Complete Hip System or Echo Bi-Metric Hip System Surgical Technique depending on which product is being used.

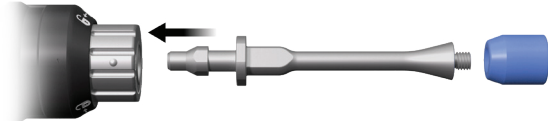

Figure 18

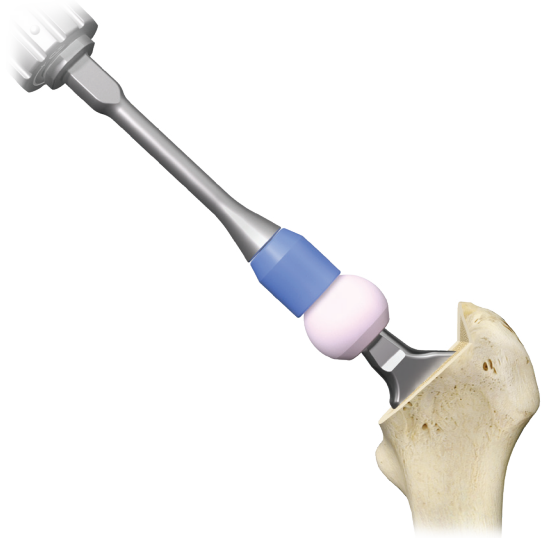

Figure 19

Femoral Head Impaction

Ensure the HAMMR handpiece is in safe mode and assemble the femoral head impaction adapter by threading the plastic impactor head onto the impaction adapter shaft (Figure 18).

Ensure the HAMMR handpiece is in safe mode (energy selector set to the zero position) and attach the modular head impaction adapter to the handpiece (Figure 18).

Switch the HAMMR energy setting from zero to High (setting 3) and impact the femoral head implant onto the femoral stem implant until it is fully seated (Figure 19).

All content herein is protected by copyright, trademarks and other intellectual property rights, as applicable, owned by or licensed to Zimmer Biomet or its affiliates unless otherwise indicated, and must not be redistributed, duplicated or disclosed, in whole or in part, without the express written consent of Zimmer Biomet. This material is intended for health care professionals. Distribution to any other recipient is prohibited.

For product information, including indications, contraindications, warnings, precautions, potential adverse effects and patient counseling information, see the package insert or contact your local Zimmer Biomet representative; visit www.zimmerbiomet.com for additional product information.

Please refer to the Instructions for Use (IFU), also known as the package insert, for this product and the IFUs and Surgical Techniques for the implants used with this surgical technique.

Zimmer Biomet does not practice medicine. This technique was developed in conjunction with health care professionals. This document is intended for surgeons and is not intended for laypersons. Each surgeon should exercise his or her own independent judgment in the diagnosis and treatment of an individual patient, and this information does not purport to replace the comprehensive training surgeons have received. As with all surgical procedures, the technique used in each case will depend on the surgeon's medical judgment as the best treatment for each patient.

Caution: Federal (USA) law restricts this device to sale by or on the order of a physician. Rx only.

For Ordering Information please refer to Literature Number 4300.

©2024, 2025 Zimmer Biomet



Legal Manufacturer

Biomet Orthopedics
P.O. Box 587
56 E. Bell Drive
Warsaw, IN 46581-0587
USA



Zimmer Surgical S.A.,
Chemin du Pré Fleuri 3,
1228 Plan Les Ouates
Switzerland

Products within this system are under the design control of various legal manufacturers. Refer to the product labeling of each device for the legal manufacturer.

www.zimmerbiomet.com