

OSS™ Orthopedic Salvage System

Intramedullary Total Femoral
Replacement For Use with
Arcos® Modular Femoral
Revision System

Surgical Technique



Table of Contents

- Indications for Use** 3
- IM Total Femur Preparation** 7
- Trialing: IM Total Femoral Rod and Distal Femur** 11
- Arcos Preparation** 15
- Trialing: Arcos** 19
- Implant Assembly** 25
- Appendix A** 39
- Ordering Information** 45

This brochure is presented to demonstrate the surgical technique utilized by Edward J. McPherson, MD, F.A.C.S.

Biomet as the manufacturer of this device, does not practice medicine and does not recommend this device or technique. Each surgeon is responsible for determining the appropriate device and technique to utilize on each individual patient.

Indications for Use

OSS INDICATIONS

1. Painful and disabled joint resulting from avascular necrosis, osteoarthritis, rheumatoid arthritis, or traumatic arthritis.
2. Correction of varus, valgus, or posttraumatic deformity.
3. Correction or revision of unsuccessful osteotomy, arthrodesis, or previous joint replacement.
4. Ligament deficiencies.
5. Tumor resections.
6. Treatment of non-unions, femoral neck fracture, and trochanteric fractures of the proximal femur with head involvement, unmanageable using other techniques.*
7. Revision of previously failed total joint arthroplasty.
8. Trauma.

These devices are to be used with bone cement unless composed of OsseoTi™ titanium alloy (not licensed in Canada) or a proximal femur is indicated for use (USA).

Biomet OSS Reduced size (RS) components offers a variety of component options for treatment in small adults and adolescents (12-21 years) that require proximal femoral, distal femoral, total femur, or proximal tibial replacement as well as, resurfacing components for the proximal tibia and distal femur (USA).

*Not applicable to Regenerex Ultra Porous Construct titanium knee augment usage (not licensed in Canada), or any other knee component.

ARCOS INDICATIONS

1. Noninflammatory degenerative joint disease including osteoarthritis and avascular necrosis.
2. Rheumatoid arthritis.
3. Correction of functional deformity.
4. Treatment of non-union, femoral neck fracture, and trochanteric fractures of the proximal femur with head involvement, unmanageable using other techniques.
5. Revision of previously failed total hip arthroplasty.

The Arcos Modular Femoral Revision System hip components are single-use implants, intended for uncemented use only.

CONTRAINDICATIONS

Absolute contraindications include: infection, sepsis, and osteomyelitis. Relative contraindications include:

- 1) uncooperative patient or patient with neurologic disorders who are incapable of following directions,
- 2) osteoporosis, 3) metabolic disorders which may impair bone formation, 4) osteomalacia, 5) distant foci of infections which may spread to the implant site, 6) rapid joint destruction, marked bone loss or bone resorption apparent on roentgenogram, and
- 7) vascular insufficiency, muscular atrophy, or neuromuscular disease.

IM Total Femur Preparation

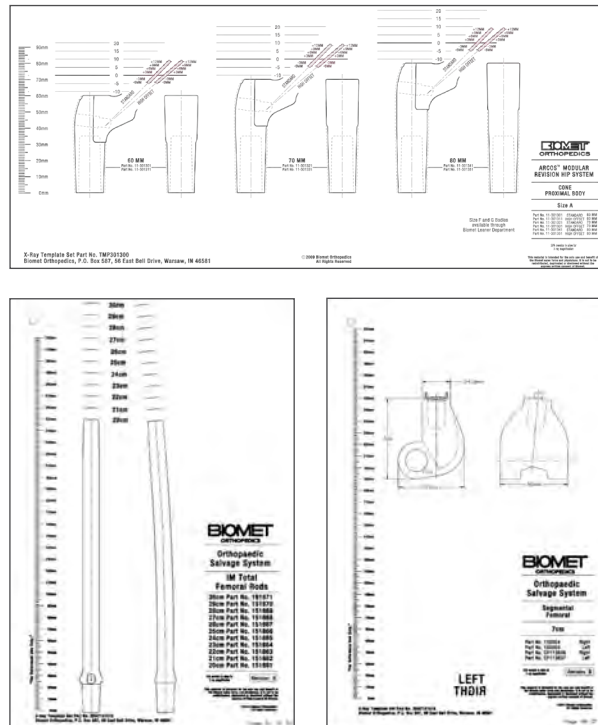

Figure 1

Pre-operative Planning

Utilize X-rays and implant templates to determine the correct implant construct length and size (Figure 1). Final determination frequently cannot be made until the actual time of surgery, however with appropriate planning a consistent operative plan with alternatives can be formulated.

Note: See Appendix A for construct options.

This technique is written for a revision scenario of the distal femur. Refer to the OSS Distal Femoral Replacement Technique for primary application.



Figure 2a



Figure 2b



Figure 2c

Canal Preparation

After existing implants have been removed, begin with the smallest diameter flexible reamer. Start at full power prior to contact sequentially reaming the entire length of the femoral canal in .5 mm diameter increments up to at least 16 mm as the diameter of the bowed IM rod is 14 mm (Figure 2a and Figure 2b).

Note: Proximal to distal reaming may be required.

For a femoral rod (Figure 2c) select the 13+ flare reamer.





Figure 3a



Figure 4a

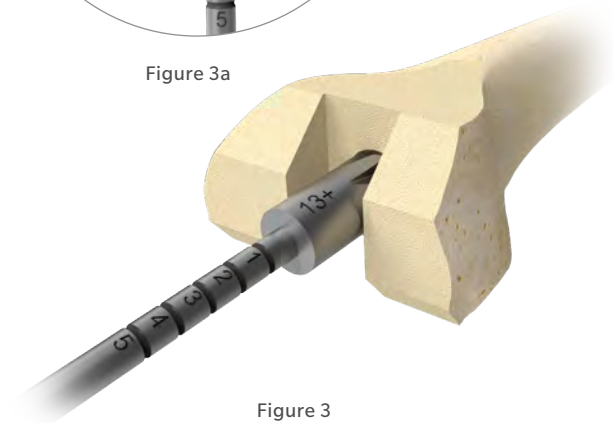

Figure 3

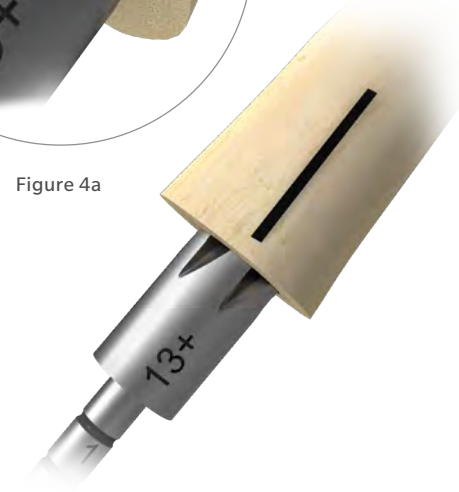

Figure 4

3 cm/5 cm Distal Femoral Bone Preparation

In a revision scenario where approximately 1 cm of distal femur has been resected, the flare reamer should be advanced 2 cm preparing for a 3 cm replacement (Figure 3 and Figure 3a) or 4 cm preparing for a 5 cm replacement.

Start at full power prior to contact and ream the canal to appropriate depth groove. Reference the OSS Distal Femoral Replacement Surgical Technique for distal femoral bone preparation and tibial bone preparation.

7 cm and Greater Distal Femoral Bone Preparation

In a segmental scenario start at full power prior to contact and ream to the etch mark on the flutes (Figure 4 and Figure 4a). Reference the OSS Segmental Distal Femoral Replacement Surgical Technique for segmental distal femoral bone preparation and tibial bone preparation.

Flare Reamer CP460476
Reamers Tray 3



Trialing: IM Total Femoral Rod and Distal Femur

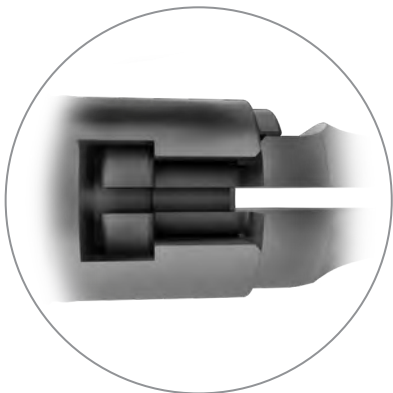

Figure 5



Figure 6

Trialing: 3 cm and 5 cm Distal Femoral Replacement

Connect the IM total rod trial directly to the distal femoral trial (Figure 5).

Insert the trial assembly into the distal femur (Figure 6).

Note: If the trial assembly is difficult to insert, additional flexible reaming may be required.

Femoral Trials
STND Femoral Provisionals Tray 4
RS Femoral Provisionals Tray 6



IM Total Rod Trials 110024554/564
OSS/Arcos IM Total Femur Case



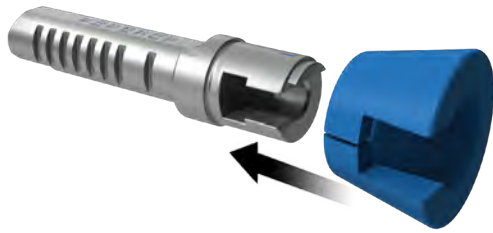

Figure 7a



Figure 7b

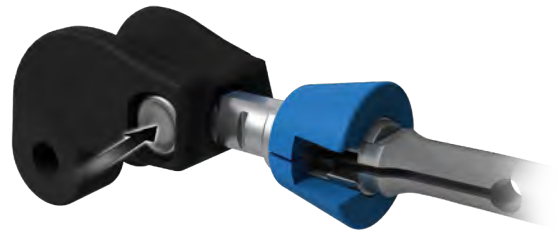

Figure 8

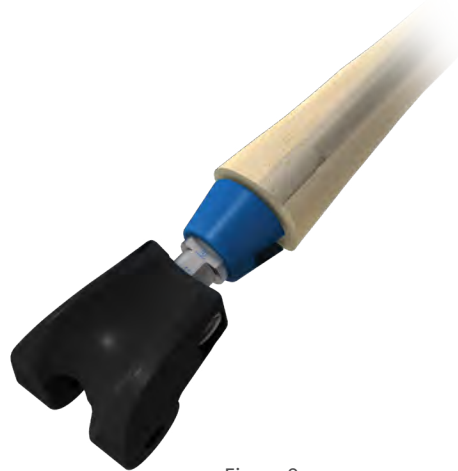

Figure 9

Trialing: 7 cm and Greater Distal Femoral

Slide the chosen augment trial onto the expandable segment trial (Figure 7a and Figure 7b). Connect the IM total rod trial to the expandable trial construct. Insert into the expandable femoral trial by pressing the expandable trial button (Figure 8). Insert the trial assembly into the distal femur (Figure 9).

Note: If the trial assembly is difficult to insert, additional reaming, using the flexible reamers, may be required.

Warning #1: Do not utilize more than one diaphyseal augment per individual diaphyseal segment.

Warning #2: Diaphyseal augments can only be utilized with the following segments which have a corresponding external taper (151836, 151837, 151838, 151839, 151840, 151841, 150842, 151843, 151844, 151845, 151846, and 151847).

Augment Trials 110018743/747
STND Segmental Provisionals Tray 5



Expandable Diaphyseal Segment Trials 110018643/646
STND Segmental Provisional Tray 5



Expandable Femoral Trial
STND Segmental Provisionals Tray 5
RS Femoral Provisionals Tray 6



Expandable Trial Button 110018632
STND Segmental Provisionals Tray 5



IM Total Rod Trials 110024554/564
OSS/Arcos IM Total Femur Case



Arcos Preparation



Figure 10



Figure 11

This technique demonstrates preparation for the Arcos cone proximal bodies. If the Arcos calcar or broach proximal femoral option is selected, please reference the Arcos Modular Femoral Revision System Surgical Technique for bone preparation.

Arcos Cone Body Preparation

Assemble the Arcos guide rod to the guide rod stem inserter by sliding the guide rod into the inserter, pulling back on the inserter collar and locking the rod into the inserter (Figure 10).

Thread the inserter assembly to the IM total rod trial.

Identify the depth on the inserter in reference to the greater trochanter to determine the height of the cone proximal body needed (Figure 11).

Note: The 50 mm, size A cone proximal body implant was not designed to accommodate a trochanteric bolt and claw. If a trochanteric bolt and claw is desired, utilize a cone proximal body implant with a 60, 70 or 80 mm vertical height.

IM Total Rod Trials 110024554/564
OSS/Arcos IM Total Femur Case



Guide Rod Stem Inserter 31-301854
Arcos Modular Femoral Revision System
593100 General Instrument Case-Top Tray



Distal Stem Reamer Guide Rod 31-301368
Arcos Modular Femoral Revision System
593100 General Instrument Case-Top Tray



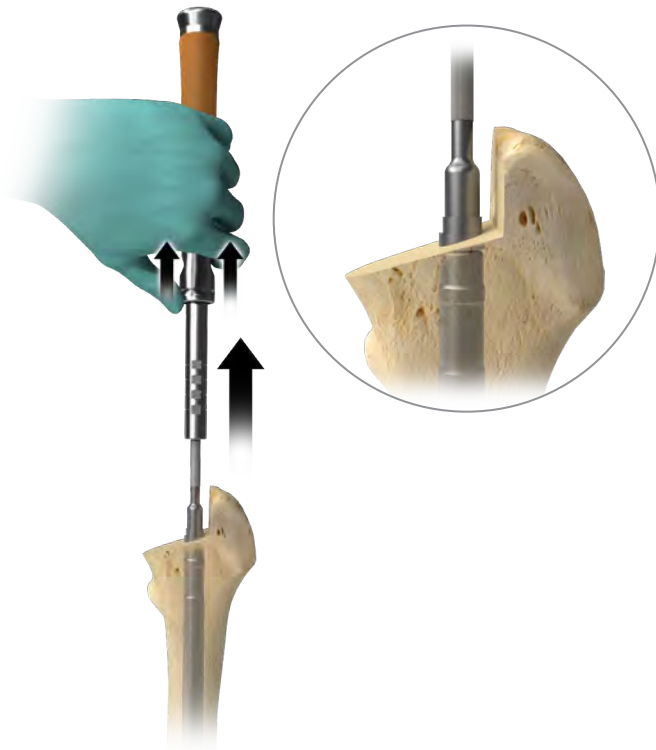

Figure 12



Figure 13

Preparation of the Metaphysis

To ream the proximal femur, release the inserter from the guide rod by pulling back on the collar spring to disengage the guide rod stem inserter, leaving the guide rod attached to the IM total rod trial (Figure 12).

ⓘ **Note:** The guide rod must be attached to the IM total rod trial to properly ream over the taper junction. The rod protects the taper junction from reamer damage and provides for accurate reaming depth.

Ream the proximal femur over the guide rod with the Arcos proximal reamers. Ream to stop. A green line is visible through the proximal reamer window once the reamer has been properly advanced. Sequentially increase the size of the reamers until the desired proximal body size (A-G) is achieved (Figure 13).

IM Total Rod Trials 110024554/564
OSS/Arcos IM Total Femur Case



Distal Stem Reamer Guide 31-301368
Arcos Modular Femoral Revision System
593100 General Instrument Case-Top Tray



Proximal Reamer 31-301361/365
Arcos Modular Femoral Revision System
593100 General Instrument Case-Top Tray



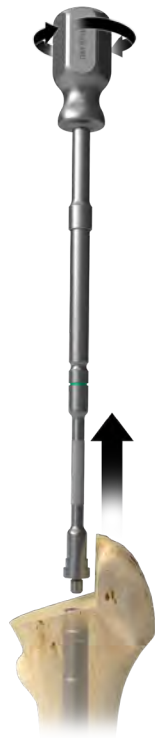

Figure 14

Preparation of the Metaphysis (cont.)

Remove the guide rod from the IM total rod trial with the removal tool, turning the guide rod removal tool counter-clockwise (Figure 14).

IM Total Rod Trials 110024554/564
OSS/Arcos IM Total Femur Case



Distal Stem Reamer Guide 31-301368
Arcos Modular Femoral Revision System
593100 General Instrument Case-Top Tray



Guide Rod Removal Tool 31-301851
Arcos Modular Femoral Revision System
593100 General Instrument Case-Top Tray



Trialing: Arcos



Figure 15

Trialing: Arcos Proximal Body

To trial the proximal body, first ensure that the taper junction on the IM total rod trial is clean and dry. Attach the cone trial that is the same height and size as the final proximal reamer and the appropriate offset. The light green trial indicates standard offset, while the purple trial represents high offset.

Note: Do not impact the proximal body trial to the rod trial.

Use the 3.5 mm hex driver to secure the cone trial to the IM total rod trial, setting the desired anteversion or retroversion in the proximal body. Do not over tighten (Figure 15).

Note: The anti-rotation handle can be placed over the neck of the trial to control anteversion or retroversion. Once the desired version has been achieved, use electrocautery to mark the desired position under the neck on the remaining bone stock.

Note: In cases with good medial bone stock, impingement between the medial neck and bone may occur causing the trial to not properly seat. Using the appropriate hand tools such as a rongeur, remove the excess bone and re-seat the trial before choosing a final implant.

IM Total Rod Trials 110024554/564
OSS/Arcos IM Total Femur Case



Arcos Cone Proximal Body Trial
Arcos Modular Femoral Revision System
593103 Cone Proximal Body Trials Instrument Case



3.5 mm Hex Driver 31-301880
Arcos Modular Femoral Revision System





Figure 16



Figure 17

Trial Reduction

Utilizing modular head, cup, and liner trials, perform a trial reduction of the hip and determine if the selected offset, leg length and joint stability are appropriate (Figure 16). In performing the trial range of motion, ensure the absence of impingement of the neck on the rim of the acetabular component or acetabular liner. Remove the cone trial from the femur with the 3.5 mm hex driver.

Insert the trial tibial baseplate (Figure 17).

Tibial Trials
 STD Tibial Provisionals Tray 9
 STD Tibial Provisionals Tray 10
 RS Tibial Provisionals Tray 11





Figure 18

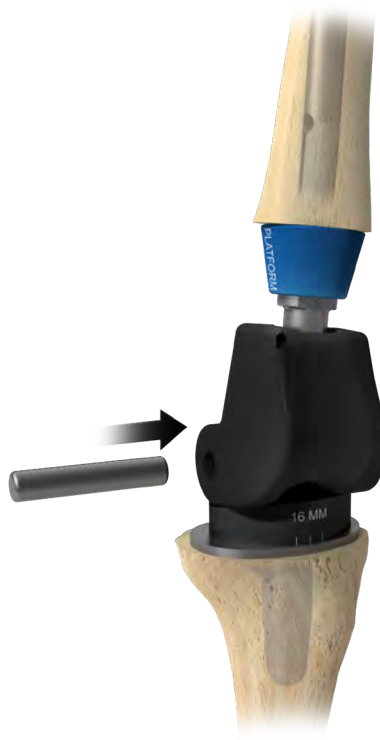

Figure 19



Figure 20

Trial Reduction (cont.)

Insert the 12 mm tibial bearing trial into the tibial baseplate trial (Figure 18).

Note: Ensure the corresponding trial axle is utilized for a Standard or RS femoral replacement.

Reduce the bearing/baseplate assembly into the trial femoral component. Insert the trial axle through the condyles so that the entire construct is fully captured (Figure 19 and Figure 20).

Select the tibial bearing that allows for full extension, but not more than 8 mm of joint distraction with longitudinal traction in full extension. Confirm fit and interaction of all components.

Note: The patella is prepared using a Biomet patella of choice. It is not recommended to use a patella smaller than 31 mm.

Tibial Trials
STND Tibial Provisionals Tray 9
STND Tibial Provisionals Tray 10
RS Tibial Provisionals Tray 11



Tibial Bearings
STND Femoral Provisionals Tray 4
RS Femoral Provisionals Tray 6



Trial Axle
STND Femoral Provisionals Tray 4
RS Femoral Provisionals Tray 6



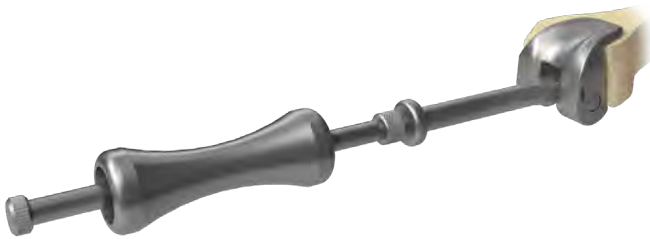

Figure 21



Figure 22

Stem Trial Extraction

For 3 and 5 cm Replacement

If the distal femoral/IM total rod trial construct is difficult to remove by hand, start by removing the proximal body trial. Reinsert the trial axle in the femoral trial and connect the distal femoral trial extractor to the slide hammer. Slide the hook around the trial axle and use the slide hammer to remove (Figure 21).

For 7 cm and Greater

If the IM total rod trial construct is difficult to remove by hand, begin by separating the proximal femoral components and the distal femoral components from the IM total rod trial. Insert the stem trial extractor onto the IM total rod trial aligning the anterior witness marks (Figure 22).

Slide Hammer 31-473621
General Instruments Tray 14



Distal Femoral Trial Extractor 110018813
General Instruments Tray 13



Stem Trial Extractor 110024532
General Instruments Tray 14





Figure 23





Figure 24

For 7 cm and Greater (cont.)

Turn clockwise and insert the stem trial extractor rod to prevent the IM total rod trial from separating from the stem trial extractor (Figure 23 and Figure 24).

Thread the slide hammer into the stem trial extractor to remove.

Implant Assembly

	Small Head/ Small Thread Locking Screw	Large Head/ Small Thread Locking Screw	Arcos Proximal/Distal Screw	Large Head/ Large Thread Locking Screw	Stacking Adapter
					
Packaged with	Segments	IM Total Femur Rod	IM Total Femur Rod	Segments	Packaged Separately

Before assembling the implants, it is important to note the screws used and what they are packaged with. Depending on the type of construct assembled, some screws may or may not be used.

Implant Assembly Without Segments

Step 1: Augment Assembly

If a femoral augment is not required, proceed to step 2.

To impact the 3 cm distal femoral component with the femoral augment, thread the augment impactor onto the impaction base (A). Vigorously impact using the distal femoral impactor (Figure 25).



Figure 25

Augment Impactor
General Instruments Tray 12



Impaction Base
General Instruments Tray 12



Distal Femoral Impactor 32-486201
General Instruments Tray 13



Step 2: IM Total Assembly

Insert the IM total impaction sleeve into the augment impactor and thread onto the impaction base (A). Insert the OSS-Arcos IM Total Femoral rod into the impaction sleeve, ensuring the distal (collared) end is exposed. Align the tapers and vigorously impact with the distal femoral impactor (Figure 26 and Figure 27).

Secure the construct with a large head/small thread locking screw packaged with the IM total rod through the distal femoral component with a 3.5 mm driver.

Do not discard the Arcos proximal/distal screw packaged with the IM total rod as it is needed to secure the final construct.

Proceed to page 32 for proximal and distal femoral insertion.

Note: Remove screws prior to impaction.



Figure 26

Figure 27

Augment Impactor
General Instruments Tray 12



Impaction Base
General Instruments Tray 12



IM Total Impaction Sleeve
110027910
OSS/Arcos IM Total Femur Case



Distal Femoral Impactor
32-486201
General Instruments Tray 13



3.5 mm Driver (Long & Short)
General Instruments Tray 13



Implant Assembly with Segments

Step 1: Augment Assembly

Insert the taper sleeve into the diaphyseal impactor and thread onto the impaction handle (A). To impact a diaphyseal segment with an augment, thread the augment impactor onto the impaction base (B). Vigorously impact with the impaction handle (Figure 28).



Figure 28

Taper Sleeve
General Instruments Tray 12



Diaphyseal Impactor
General Instruments Tray 12



Impaction Handle
General Instruments Tray 12



Impaction Base
General Instruments Tray 12



Augment Impactor
General Instruments Tray 12





Step 2: IM Total Rod Assembly







Insert the taper sleeve into the diaphyseal impactor and thread onto the impactation handle (A). Insert the IM total impactation sleeve into the augment impactor and thread onto the impactation base (B). Vigorously impact with the impactation handle.

Secure the construct using a small head/small thread locking screw packaged with the segment (C). When using larger diaphyseal segments it will be necessary to use the 3.5 mm long driver (Figure 29).

Do not discard the Arcos proximal/distal screw packaged with the IM total rod as it is needed to secure the final construct.

Note: Remove screws prior to impactation.

Figure 29

<p>Diaphyseal Impactor General Instruments Tray 12</p> 	<p>Taper Sleeve General Instruments Tray 12</p> 	<p>Impactation Handle General Instruments Tray 12</p> 	<p>Augment Impactor General Instruments Tray 12</p> 	<p>IM Total Impactation Sleeve 110027910 OSS/Arcos IM Total Femur Case</p> 
<p>Impactation Base General Instruments Tray 12</p> 	<p>3.5 mm Driver (Long & Short) General Instruments Tray 13</p> 			

Step 3: Distal Femoral Assembly

Insert the IM total impaction sleeve into the augment impactor and thread onto the impaction base (A). Align the segmental distal femoral implant with the IM total rod construct. Vigorously impact with the distal femoral impactor.

Secure the construct using a large head/large thread locking screw packaged with the segment (B) (Figure 30).

Note: Remove screws prior to impaction.



Figure 30









Impaction Handle General Instruments Tray 12	Diaphyseal Impactor General Instruments Tray 12	Taper Sleeve General Instruments Tray 12	Impaction Base General Instruments Tray 12	Augment Impactor General Instruments Tray 12
				
IM Total Impaction Sleeve 110027910 OSS/Arcos IM Total Femur Case	Distal Femoral Impactor 32-486201 General Instruments Tray 13	3.5 mm Driver (Long & Short) General Instruments Tray 13		
				



Figure 31



Figure 32a

Figure 32b



Figure 33

Distal Femoral Insertion

Place the IM total taper cap onto the IM total rod to keep the taper clean and dry (Figure 31).

Cement using contemporary techniques and insert the construct up through the distal end of the femur. Remove the IM total taper cap and thoroughly clean excess cement off the taper if necessary (Figure 32a and Figure 32b).

Proximal Body Insertion

Once the proper body height and size has been determined, thread the proximal body inserter to the proximal body implant, ensuring the anti-rotation tabs are locked in the proper orientation.

Impact the proximal body to the taper junction on the IM total rod implant with several blows of the mallet (Figure 33). The implant will be seated when there is an audible change in the pitch during impaction or the etch mark on the inserter handle is advanced to the previously determined ream depth.

IM Total Taper Cap 110028036
OSS/Arcos IM Total Femur Case



Proximal Body Inserter 31-301000
Arcos Modular Femoral Revision System
593100 General Instrument Case-Bottom Tray





Figure 34



Figure 35

Inserting the Locking Screw

To lock the proximal body implant to the already secured distal femoral/IM total femur construct, thread the locking screw into the top of the proximal body using the 3.5 mm hex driver (Figure 34).

ⓘ **Note:** If the screw does not thread into the distal femoral/IM total femur construct, the proximal body is not fully seated and the implant insertion steps must be repeated.

Final Reduction

If desired, another trial reduction can be accomplished prior to selecting final head size and impacting the modular head onto the stem (Figure 35). Provisional heads in seven neck lengths allow an additional trial reduction, using the actual implant to ensure proper leg length and stability. After fully seating the femoral component, impact the appropriate modular head onto the clean, dry taper.

3.5 mm Hex Driver 31-301880
Arcos Modular Femoral Revision System





Figure 36



Figure 37

Trochanteric Bolt Assembly

Once the final implant has been reduced, the osteotomy can be repaired and stabilized by choosing one of the auxiliary options available in the Arcos System and attaching it directly to the implant.

Note: All proximal body designs accept a bolt and claw except the 50A Cone and 50A Calcar bodies.

Depending on the surgical approach and operative hip, select the appropriate trochanteric bolt guide instrument (Figure 36).

Use the 5.0 mm hex driver to thread the trochanteric bolt guide into the insertion hole on the proximal body, ensuring the anti-rotation tabs are locked to the proximal body implant. Place the trochanteric fragment between the implant and the trochanteric bolt guide (Figure 37).

If utilizing the trochanteric claw use the claw trials (large or small) to select the needed width.

Note: Guide may be easier to attach before hip is reduced.

Troch Bolt Guide 31-301005/006
Arcos Modular Femoral Revision System
593108 Troch/Bolt Instrument Case



5.0 mm Hex Driver 31-301853
Arcos Modular Femoral Revision System
593108 Troch/Bolt Instrument Case



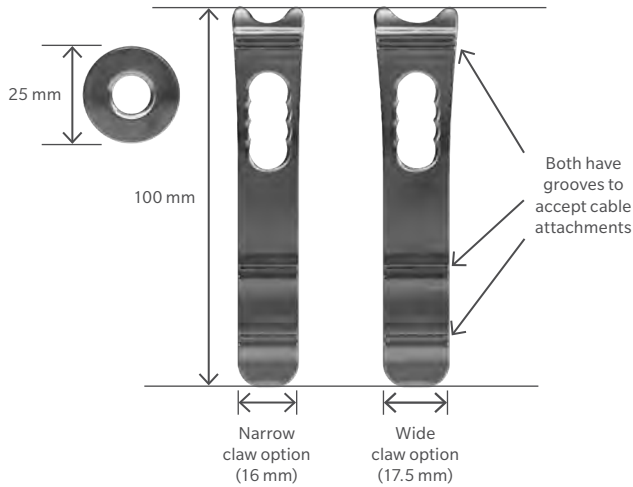

Figure 38

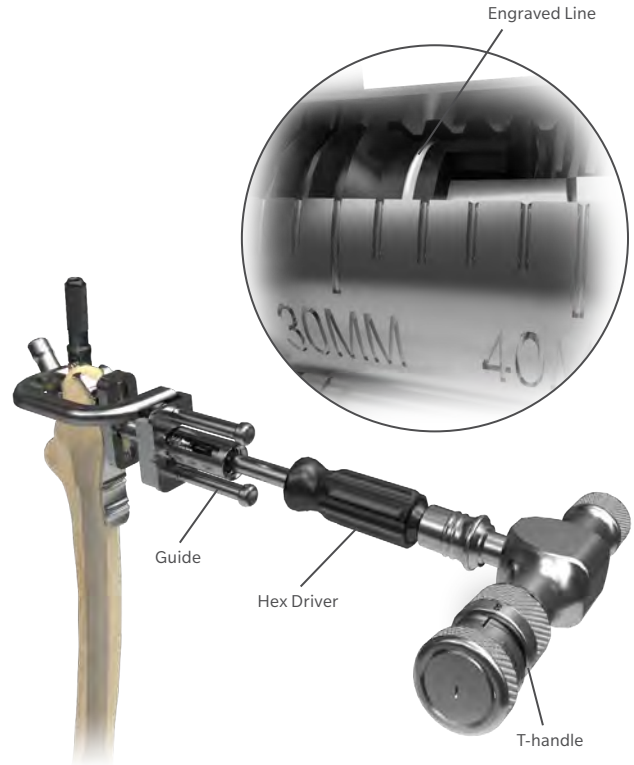

Figure 39

Trochanteric Bolt Assembly (cont.)

Note: Both the large and small claw are 100 mm in length, measured from the top to bottom. The button is 25 mm in diameter (Figure 38).

Once the trochanteric fixation option has been determined, compress the auxiliary implant to the bone fragment by threading the plunger tightly against the auxiliary implant using the 5.0 mm hex driver and T-handle in the torque limiting position (Figure 39).

Note: If utilizing the claw auxiliary option, ensure that the head of the plunger is aligned with a hole in the claw to ensure that the bolt will pass through the claw into the implant.

Select the bolt length that corresponds with the depth marks on the outside of the trochanteric bolt guide as measured according to the position of the engraved line on the plunger. Choose the trochanteric bolt drill bit that matches the size of the proximal body implant (Size A–G) regardless of height or body style.

Example: If a size B cone body is used, select the size B trochanteric bolt drill bit. Selecting the correct size will prevent the drill from contacting the implant.

Note: Bolts are available in 1 mm increments.

Trial Claw 31-302101/102
Arcos Modular Femoral Revision System
593108 Troch/Bolt Instrument Case



Torque Limiting T-Handle 31-301850
Arcos Modular Femoral Revision System
593100 General Instrument Case-Top Tray



5.0 mm Hex Driver 31-301853
Arcos Modular Femoral Revision System
593108 Troch/Bolt Instrument Case



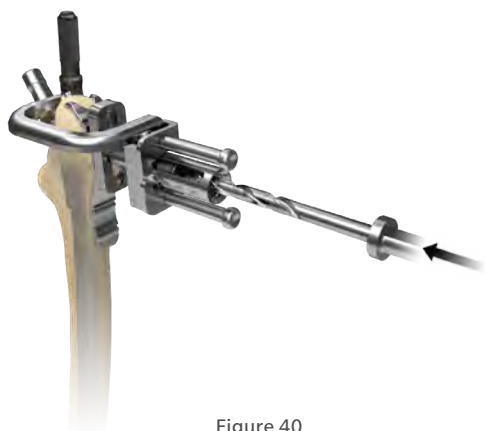

Figure 40

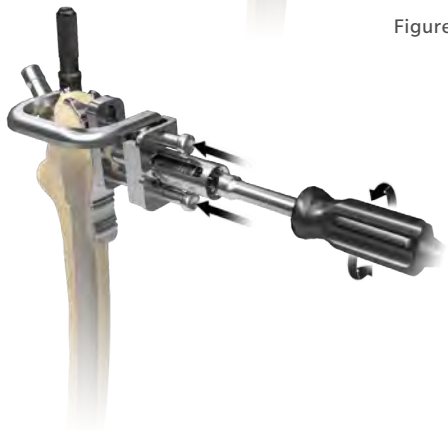

Figure 41

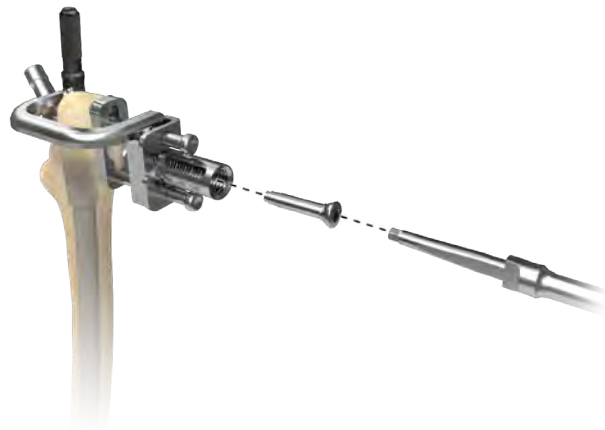

Figure 42

Trochanteric Bolt Assembly (cont.)

Advance the appropriate size drill bit through the plunger until the built-in stop bottoms out on the cylindrical surface of the outrigger (Figure 40).

Note: It is not possible to drill through the bolt hole on the claw trial, preparation must be performed with the final implant in place.

Compress the arms of the trochanteric bolt guide tightly to the auxiliary implant and remove the measurement plunger with the 5.0 mm hex driver (Figure 41). Attach the 5.0 mm hex driver to the T-handle and set to torque limiting position.

Thread the bolt through the trochanteric bolt guide and into the proximal body until a “click” is felt and heard (Figure 42).

Note: It may be necessary to give the T-handle a few small taps with the mallet to ensure the bolt drops into the hole in the proximal body.

Troch Bolt Drill 31-301881/885
Arcos Modular Femoral Revision System
593108 Troch/Bolt Instrument Case



5.0 mm Hex Driver 31-301853
Arcos Modular Femoral Revision System
593108 Troch/Bolt Instrument Case



Torque Limiting T-Handle 31-301850
Arcos Modular Femoral Revision System
593100 General Instrument Case-Top Tray





Figure 43



Figure 44

Trochanteric Bolt Assembly (cont.)

Once the bolt is secured to the implant, unthread the trochanteric bolt guide from the proximal body using the 5.0 mm hex driver (Figure 43).

- ⓘ **Note:** If utilizing the claw auxiliary option, cables may be added in the grooves of the claw for additional stability (Figure 44).
- ⓘ **Note:** If the trochanteric bolt guide is difficult to remove, unthread the trochanteric bolt by 1/2 of a turn, remove the guide and retighten the bolt with the T-handle in torque limiting position.

5.0 mm Hex Driver 31-301853
Arcos Modular Femoral Revision System
593108 Troch/Bolt Instrument Case



Appendix A

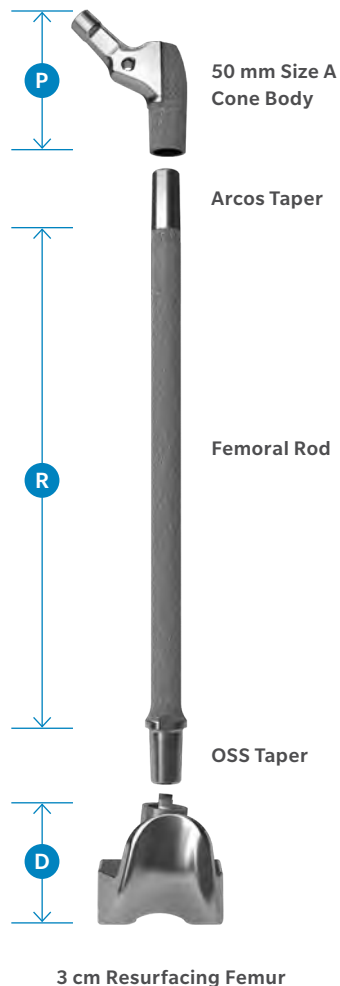

Example – Calculation Using Resurfacing Distal Femur

Overall Construct Length =
 Proximal (Arcos) + **R**od + **D**istal (OSS)

Assuming the proposed femoral construct length equals 35 cm and selected components are:

- P** = Arcos Cone Body Size A (50 mm)
- R** = Rod (24 cm)
- D** = Distal (6 cm)

5 cm + 24 cm + 6 cm = 35 cm

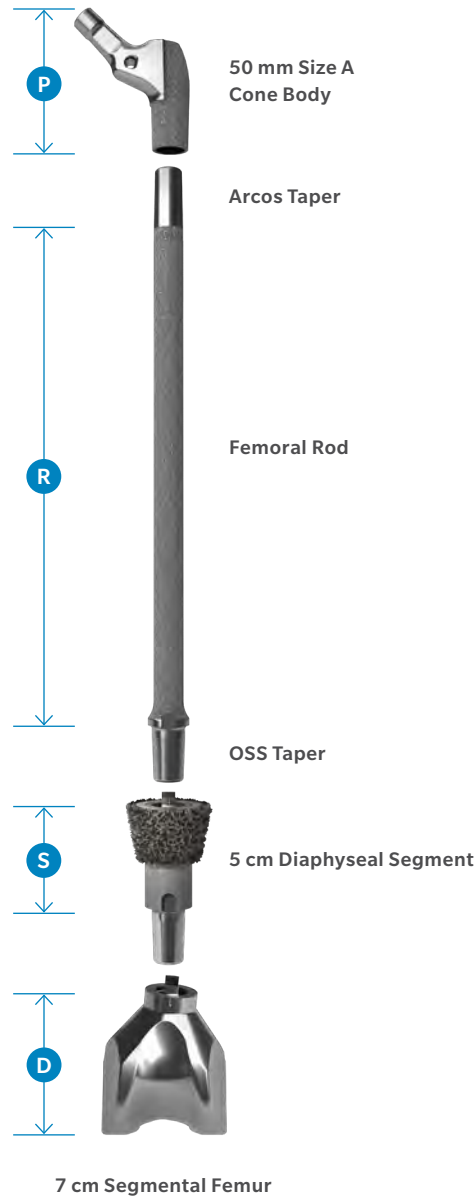

Example – Calculation Using Segmental Distal Femur

Overall Construct Length =
Proximal (Arcos) + Rod + Segment + Distal (OSS)

Assuming the proposed femoral construct length equals 41 cm and selected components are:

- P** = Arcos Cone Body Size A (50 mm)
- R** = Rod (24 cm)
- S** = Segment (5 cm)
- D** = Distal (7 cm)

5 cm + 24 cm + 5 cm + 7 cm = 41 cm

OSS Total IM Femoral Rods

	Part Number	Actual Length "R"	Diameter
 <p>R Rod*</p>	151861	20 cm	14 mm
	151862	21 cm	14 mm
	151863	22 cm	14 mm
	151864	23 cm	14 mm
	151865	24 cm	14 mm
	151866	25 cm	14 mm
	151867	26 cm	14 mm
	151868	27 cm	14 mm
	151869	28 cm	14 mm
	151870	29 cm	14 mm
	151871	30 cm	14 mm

*Arcos Proximal/Distal Screw (11-301000) and Large Head/Small Thread Locking Screw (150475) are packaged with the IM Total Rod implant.

OSS Tapered Diaphyseal Segments

	Part Number	Actual Length "S"
 <p>S Diaphyseal Segment</p>	151836	3 cm
	151837	4 cm
	151838	5 cm
	151839	7 cm
	151840	9 cm
	151841	11 cm
	151842	13 cm
	151843	15 cm
	151844	17 cm
	151845	19 cm
	151846	21 cm
151847	23 cm	

OSS RS Distal Femoral Bodies

	Part Number	Description	Actual Length "D"
 <p>D Distal Femur</p>	151801	OSS RS 3 cm Resurfacing – RT	6 cm
	151802	OSS RS 3 cm Resurfacing – LT	6 cm
	151803	OSS RS 5 cm Resurfacing – RT	8 cm
	151804	OSS RS 5 cm Resurfacing – LT	8 cm
	161009	OSS RS 7 cm Elliptical Segmental – RT	7 cm
	161010	OSS RS 7 cm Elliptical Segmental – LT	7 cm
	161011	OSS RS 7 cm Segmental – RT	7 cm
	161012	OSS RS 7 cm Segmental – LT	7 cm
	161013	OSS RS 8.5 cm Elliptical Segmental – RT	8.5 cm
	161014	OSS RS 8.5 cm Elliptical Segmental – LT	8.5 cm
	161123	OSS RS 8.5 cm Segmental – RT	8.5 cm
	161124	OSS RS 8.5 cm Segmental – LT	8.5 cm

OSS Distal Femoral Bodies

	Part Number	Description	Actual Length "D"
 <p>D Distal Femur</p>	151805	OSS 3 cm Resurfacing – RT	6 cm
	151806	OSS 3 cm Resurfacing – LT	6 cm
	151807	OSS 5 cm Resurfacing – RT	8 cm
	151808	OSS 5 cm Resurfacing – LT	8 cm
	150356	OSS 7 cm Elliptical Segmental – RT	7 cm
	150357	OSS 7 cm Elliptical Segmental – LT	7 cm
	150354	OSS 7 cm Segmental – RT	7 cm
	150355	OSS 7 cm Segmental – LT	7 cm
	150495	OSS 8.5 cm Elliptical Segmental – RT	8.5 cm
	150496	OSS 8.5 cm Elliptical Segmental – LT	8.5 cm
	161092	OSS 8.5 cm Segmental – RT	8.5 cm
	161093	OSS 8.5 cm Segmental – LT	8.5 cm



Arcos Proximal Cone Bodies

	Standard Offset Part Number	High Offset Part Number	Description	Actual Length "P"	Size
 <p>P Proximal Cone Body</p>	11-301300	11-301310	Cone Proximal Body	50 mm	A
	11-301301	11-301311	Cone Proximal Body	60 mm	A
	11-301302	11-301312	Cone Proximal Body	60 mm	B
	11-301303	11-301313	Cone Proximal Body	60 mm	C
	11-301304	11-301314	Cone Proximal Body	60 mm	D
	11-301305	11-301315	Cone Proximal Body	60 mm	E
	11-301306	11-301316	Cone Proximal Body	60 mm	F
	11-301307	11-301317	Cone Proximal Body	60 mm	G
	11-301321	11-301331	Cone Proximal Body	70 mm	A
	11-301322	11-301332	Cone Proximal Body	70 mm	B
	11-301323	11-301333	Cone Proximal Body	70 mm	C
	11-301324	11-301334	Cone Proximal Body	70 mm	D
	11-301325	11-301335	Cone Proximal Body	70 mm	E
	11-301326	11-301336	Cone Proximal Body	70 mm	F
	11-301327	11-301337	Cone Proximal Body	70 mm	G
	11-301341	11-301351	Cone Proximal Body	80 mm	A
	11-301342	11-301352	Cone Proximal Body	80 mm	B
	11-301343	11-301353	Cone Proximal Body	80 mm	C
	11-301344	11-301354	Cone Proximal Body	80 mm	D
	11-301345	11-301355	Cone Proximal Body	80 mm	E
	11-301346	11-301356	Cone Proximal Body	80 mm	F
	11-301347	11-301357	Cone Proximal Body	80 mm	G

Ordering Information

OSS / Arcos IM Total Femur Case



Product	Label	Part Number	Size	Description
	A	110024554	20 cm	OSS IM Total Femur Rod Trial
		110024555	21 cm	
		110024556	22 cm	
		110024557	23 cm	
		110024558	24 cm	
		110024559	25 cm	
		110024560	26 cm	
		110024561	27 cm	
		110024562	28 cm	
		110024563	29 cm	
110024564	30 cm			
	B	110027910	-	IM Total Impaction Sleeve
	C	110028036	-	IM Total Taper Cap
		110030552	-	Case Only

ORDERING INFORMATION

X-Ray Templates

Part Number	Description
XRAY151515	OSS Templates
XRAY151514	OSS RS Templates
XRAY301300	Arcos Cone Bolt Claw

This publication and all content herein is protected by copyright, trademarks and other intellectual property rights owned by or licensed to Biomet Inc. or its affiliates, unless otherwise indicated, and must not be redistributed, duplicated or disclosed without the express written consent of Biomet. Use for any other purposes is prohibited. Distribution to any other recipient is prohibited.

This material is intended for the sole use and benefit of the Biomet sales force and physicians.

For complete product information, including indications, contraindications, warnings, precautions and potential adverse effects, see the package insert and Biomet's website.

©2016 Zimmer Biomet



Authorized Representative

Biomet UK Ltd.
Waterton Industrial Estate
Bridgend, South Wales
CF31 3XA
UK



Legal Manufacturer

Biomet Orthopedics
P.O. Box 587
56 E. Bell Drive
Warsaw, Indiana 46581-0587
USA

www.zimmerbiomet.com



ZIMMER BIOMET

Your progress. Our promise.™

0143.2-US-en-REV0416

CE 0086

CE mark on a surgical technique is not valid unless there is a CE mark on the product label.