



Zimmer®
MotionLoc® Screw
for the Periarticular
Locking Plate
System

Surgical Technique



Background

A plating construct needs to be strong enough to support the damaged bone while the fracture heals. However, too much stiffness forces the body to heal through osteonal or primary/direct healing. Primary healing requires nearly perfect anatomic reduction and rigid compression for absolute stability which has proven to be a very complex and unforgiving procedure.¹ In animal studies, Far Cortical Locking Technology provides controlled axial flexibility to promote fracture healing through callus formation, or secondary healing, by stressing the fracture with micromotion at the fracture site.² The idea of Far Cortical Locking Technology motivated Zimmer to create Zimmer® MotionLoc® Screws for NCB® Plates and now, a stainless steel version for use with Zimmer Periarticular Locking Plates.

ZIMMER MotionLoc SCREW DESIGN

MotionLoc Screws look different than most cortical screws. The picture below outlines the different design aspects.

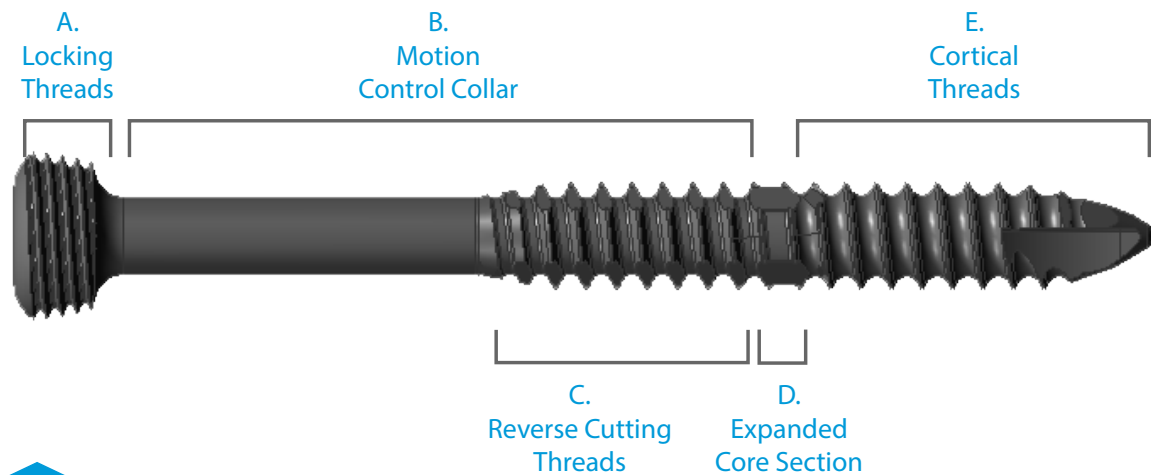

Fig. 1

A. Locking Threads

This is the portion of the screw that locks into the plate. The head of the screw is threaded to match the threaded holes in the plates.

B. Motion Control Collar

This is the portion of the MotionLoc Screw that makes it unique. The diameter of this portion has been reduced in comparison to the distal end of the screw. This allows the screw within the drilled hole to flex through elastic deformation without permanently deforming the screw. This is called the working length of the screw because this is the area that flexes a controlled amount to create the desired micromotion at the fracture site (Fig. 2).

NOTE: Working Length

Increased flexibility of the screw is directly proportional to the length of the screw. Mechanically, MotionLoc Screws behave in a manner similar to a cantilever beam. As the length of the beam/screw increases so does the beam/screw flexibility.

It is important to maximize the working length of the screw, so centering the screw in the bone is key. The figure below shows how the screw is affected when placed off-center (Fig. 4).

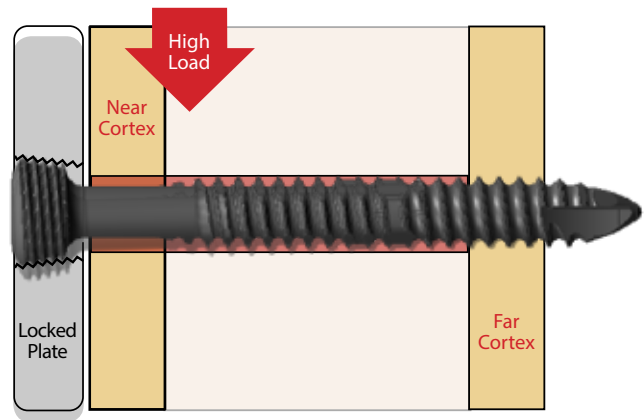

Fig. 2

Motion Control Collar

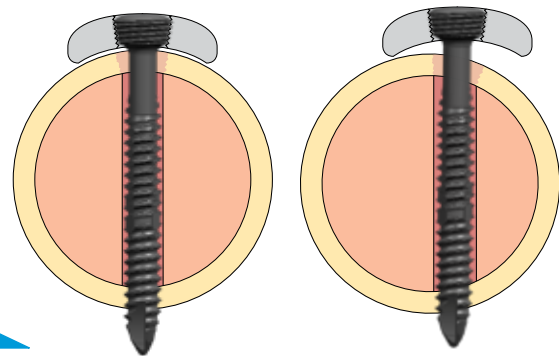

Fig. 3

To maximize working length, center screw in bone.

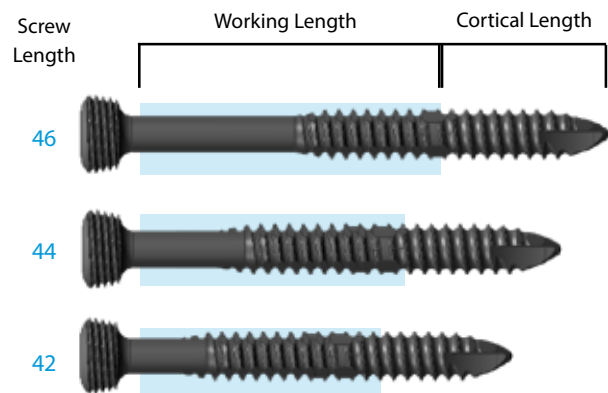

Fig. 4

As the screw length increases, the working length increases, and so does the screw flexibility.

C. Reverse Cutting Threads

The reverse cutting threads on the working length of the screw ease screw removal. The reverse cutting threads are designed to engage with the near cortex before the threads on the tip of the screw disengage with the far cortex, so the screw can be backed out (Fig. 5).

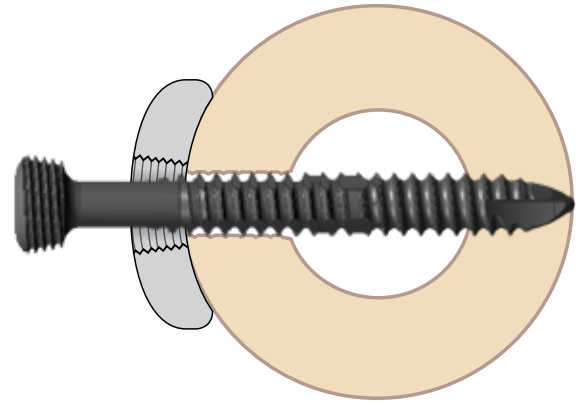

Fig. 5

Reverse cutting threads

D. Expanded Core Section

The expanded core section of the screw is a little larger than the outer diameter of the motion control collar. As the screw advances through the drilled hole upon insertion, it leaves a bigger motion envelope behind it for the working length of the screw (Fig. 6).

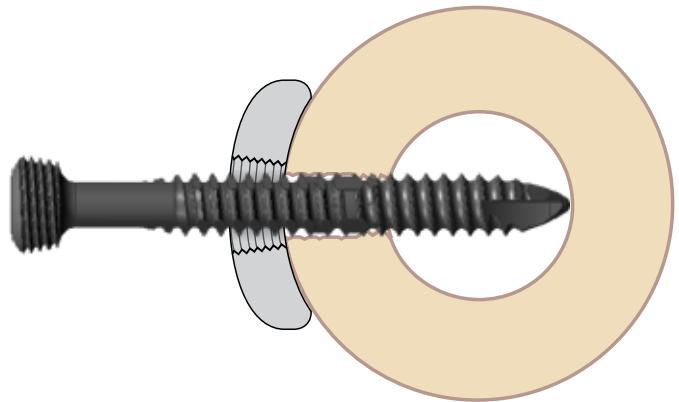

Fig. 6

Expanded Core section passing through the near cortex.

E. Cortical Threads

This is the portion that fixes into the cortical bone for hold. It has the same thread form as a standard cortical screw and is inserted using a standard surgical procedure. Since MotionLoc screws are only fixed in the far cortex, radiographs must be inspected to confirm the screw tip has completely engaged that cortex.

The MotionLoc Screws are intended for use in the diaphyseal segment of a fracture where screw purchase in the far cortex opposite the plate can be obtained. They are not for use in the metaphysis or epiphysis of the bone.

Reducing Stiffness of Locked Plating Constructs

MotionLoc Screws reduce the locked plating construct stiffness by more than 58% while retaining construct strength.³ The stiffness reduction through the screws creates nearly parallel micromotion at the fracture site.

Indications for Use

MotionLoc Screws, when used with the Periarticular Locking Plate System, are indicated for temporary internal fixation and stabilization of osteotomies and fractures of long bones, including:

- Comminuted fractures
- Supracondylar fractures
- Intra-articular and extra-articular condylar fractures
- Fractures in osteopenic bone
- Nonunions
- Malunions

Contraindications

Contraindications include:

- All concomitant diseases that may impair the fixation of the implant and/or the success of the intervention.
- Acute or chronic, local or systemic infections.
- Severe muscular, neural, or vascular diseases that endanger the extremities involved.
- Lack of bone substance or bone quality, which makes stable seating of the screws impossible or results in an unstable screw/plate construct.
- Allergy to the implanted material.

Preoperative Preparation

After assessing the fracture radiographically and preparing a preoperative plan, position the patient on the appropriate table. Ensure that the fluoroscope can be positioned to visualize the appropriate bone in both the lateral and anterior/posterior views. For specific preoperative positioning, refer to the surgical technique for the appropriate Zimmer Periarticular Locking Plate being used.

Plate Selection

Two factors to consider when choosing plate length: (1) Location of the fracture and (2) the number and distribution of the screws around the fracture site.

W WARNING: When considering the number and distribution of screws, remember that a minimum of 3 MotionLoc screws must be placed on the diaphyseal side of the fracture to use the product. MotionLoc screws should be placed (1) distal to the fracture in proximal humerus and proximal tibia fractures; and (2) proximal to the fracture for distal femur and distal tibial fractures. The remainder of the Periarticular Locking Plate is secured as described in the Periarticular Locking Plate package insert and corresponding surgical technique (Proximal Tibial Plates, Distal Tibial Plates, Proximal Humeral Plates, and Distal Femoral Plates).

With the Zimmer Periarticular Locking Plate System, the threaded-round holes in the shaft are the locking holes. MotionLoc Screws must lock into the plate and must be inserted into the threaded-round shaft holes (Fig. 7).

MotionLoc screws may be grouped more tightly around the fracture than with standard locking screws as they reduce the stiffness and translate micromotion into the fracture site. This allows them to be placed in consecutive locking holes.

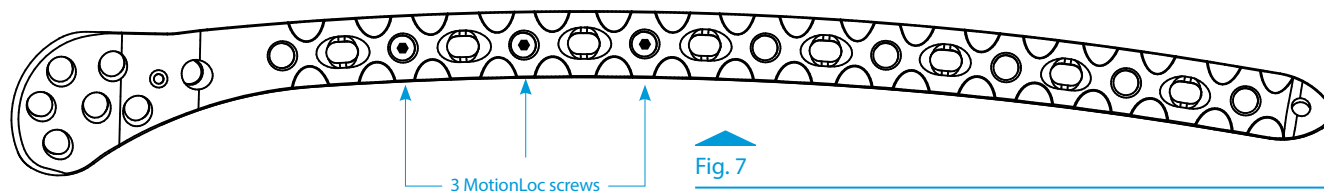

Fig. 7

MotionLoc Screw placement

Plate Placement and Fracture Reduction

Center the plate on the bone as much as possible. MotionLoc screws function best when the working length is maximized across the widest portion of the bone (Fig. 8).

Provisional fixation with k-wires or drill bits may be used to more accurately place the plate.

Fix the metaphyseal and epiphyseal segments of the fracture as described in the surgical techniques for the corresponding plate used.

W WARNING: Standard Periarticular Locking screws or cortical screws should NOT be used in the same fracture segment as the MotionLoc Screws as this may lead to a stress riser and potential failure. Compression technique should only be used in the metaphysis.

4.5mm Zimmer MotionLoc Screw Technique

To insert the 4.5mm Zimmer MotionLoc Screws, thread the 3.7mm Standard Cannula (Blue Ring) into the desired locking hole.

Use the 3.7mm Standard Drill through the cannula to drill a pilot hole. Use the fluoroscope to confirm the drill position in both the A/P and lateral planes. Remove the cannula.

If drilling in hard cortical bone, tap the far cortex with the 4.5mm Locking Screw Tap.

Screw Length Measurement

MotionLoc screws should fully engage the far cortex (Fig. 9). Use the 4.5mm Locking Screw Depth Gauge to obtain a screw length reading. Add 2mm to that reading to select the appropriate MotionLoc screw length.

Screw Insertion

Select the appropriate MotionLoc Screw from the MotionLoc Screw Caddy for Zimmer Periarticular Locking Plate System. Insert the screw using the 5.0mm Hex Screwdriver until it has threaded into the locking hole of the Periarticular Locking Plate.

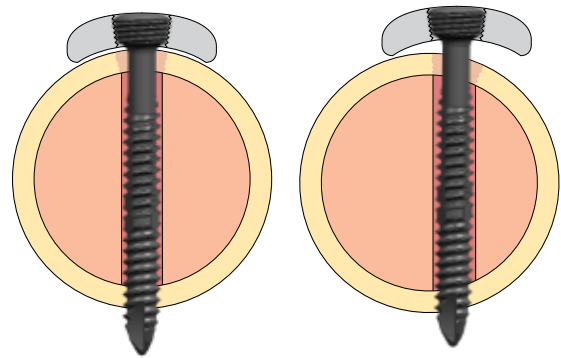

Fig. 8

Center the MotionLoc Screws

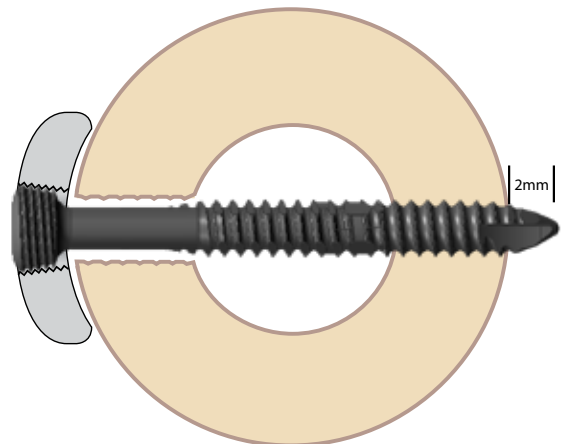

Fig. 9

Screw Length Measurement

N NOTE: To ensure that the MotionLoc Screw finds the drilled hole in the far cortex, it is important to align the screw in the direction of the drilled hole while inserting the screw. Use alignment of the depth gauge prior to its removal to determine proper orientation of screw prior to placement.

Follow the same procedure to insert a MINIMUM of three (3) MotionLoc Screws into the shaft of the bone. Ensure that all screws are securely tightened.

3.5mm MotionLoc Screw Technique

To insert the 3.5mm MotionLoc Screws, thread the 2.7mm Standard Cannula (Black Ring) into the desired locking hole.

Use the 2.7mm Standard Drill through the cannula to drill a pilot hole. Use the fluoroscope to confirm the drill position in both the A/P and lateral planes. Remove the cannula.

If drilling in hard cortical bone, tap the far cortex with the 3.5mm Locking Screw Tap.

Screw Length Measurement

Use the 3.5mm Locking Screw Depth Gauge to obtain a screw length reading. Add 2mm to that reading to select the appropriate screw length. MotionLoc screws should fully engage the far cortex.

Screw Insertion

Select the appropriate MotionLoc Screw from the MotionLoc Screw Caddy for Zimmer Periarticular Locking Plate System. Insert the screw using the Small Hex Screwdriver until it has threaded into the locking hole of the Periarticular Locking Plate.

Follow the same procedure to insert a MINIMUM of three (3) MotionLoc Screws into the shaft of the bone. Ensure that all screws are securely tightened.

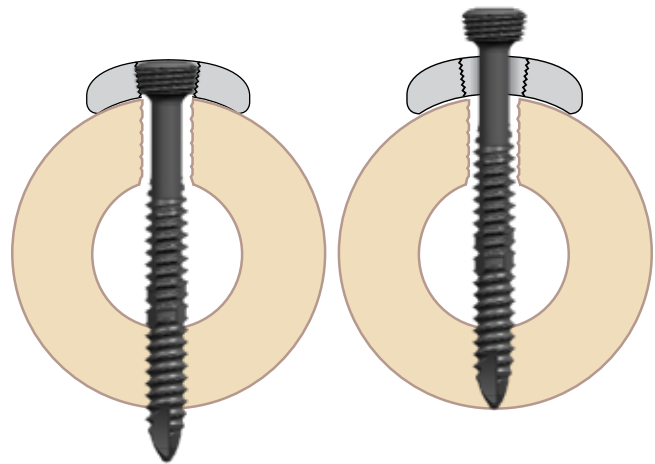

Fig. 10

Screw removal

Implant Removal

MotionLoc screws have been designed to aid in the removal process. A portion of the screw has reverse cutting threads to engage in the near cortex bone as the cortical threads disengage from the far cortex of bone (Fig. 10).

To remove the Zimmer Periarticular Locking Plate, back off all bone screws. This prevents rotation of the plate when removing the last screw. Then completely remove all screws with the screwdriver, ensuring that the tip of the screwdriver is completely seated in the hex drive of the screw. Failure to do so could damage the hex drive and complicate the extraction of the implant.

References

1. Skirving AP, Day R, Macdonald W, McLaren R: Carbon fiber reinforced plastic (CFRP) plates versus stainless steel dynamic compression plates in the treatment of fractures of the tibiae in dogs. Clin Orthop Relat Res 1987; 224:117-124.
2. Bottlang M, et al. Far cortical locking can improve healing of fractures stabilized with locking plates. J Bone Joint Surg (A), 92:7,2010.
3. Data on file at Zimmer. (ZRR 2671-13 & ZRR 2674-13)

DISCLAIMER:

This material is intended for healthcare professionals and the Zimmer Biomet sales force. Distribution to any other recipient is prohibited. For indications, contraindications, warnings, precautions, potential adverse effects and patient counseling information, see the package insert or contact your local representative; visit www.zimmerbiomet.com for additional product information. All content herein is protected by copyright, trademarks and other intellectual property rights, as applicable, owned by or licensed to Zimmer Biomet or its affiliates unless otherwise indicated, and must not be redistributed, duplicated or disclosed, in whole or in part, without the express written consent of Zimmer Biomet.

For indications, contraindications, warnings, precautions, potential adverse effects and patient counseling information, see the package insert or contact your local representative; visit www.zimmerbiomet.com for additional product information. Check for country product clearances and reference product specific instructions for use. Zimmer Biomet does not practice medicine. This technique was developed in conjunction with health care professional. This document is intended for surgeons and is not intended for laypersons. Each surgeon should exercise his or her own independent judgment in the diagnosis and treatment of an individual patient, and this information does not purport to replace the comprehensive training surgeons have received. As with all surgical procedures, the technique used in each case will depend on the surgeon's medical judgment as the best treatment for each patient. Results will vary based on health, weight, activity and other variables. Not all patients are candidates for this product and/or procedure. Caution: Federal (USA) law restricts this device to sale by or on the order of a surgeon. Rx only.

Contact your Zimmer Biomet representative or visit us at www.zimmerbiomet.com

The CE mark is valid only if it is also printed on the product label.

