

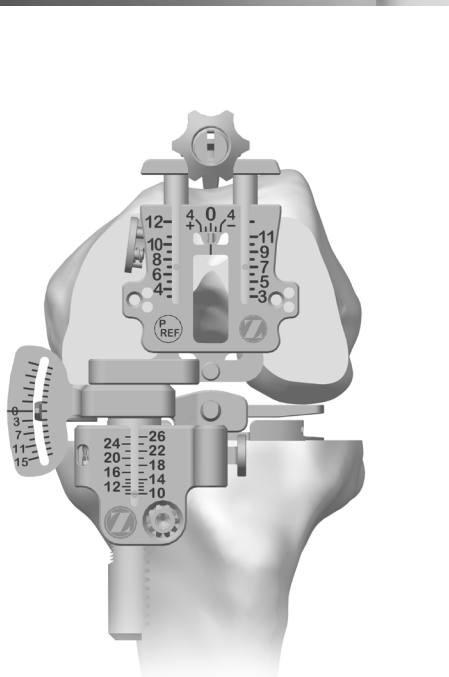

Zimmer FuZion™ Instruments

Surgical Technique

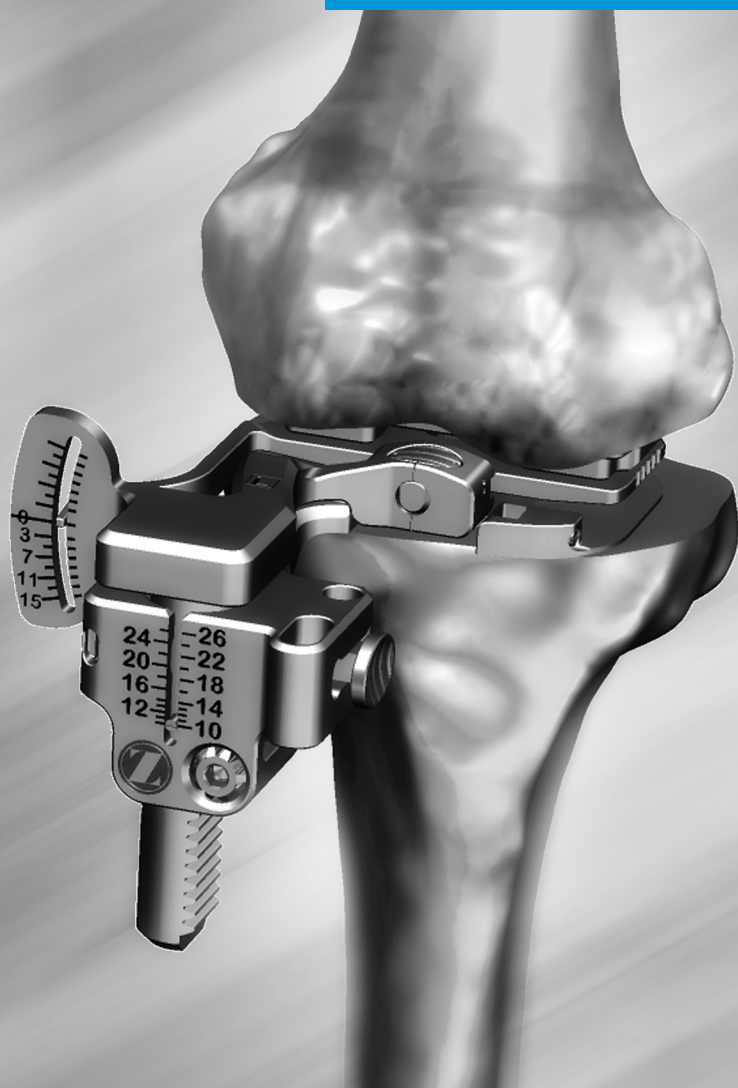
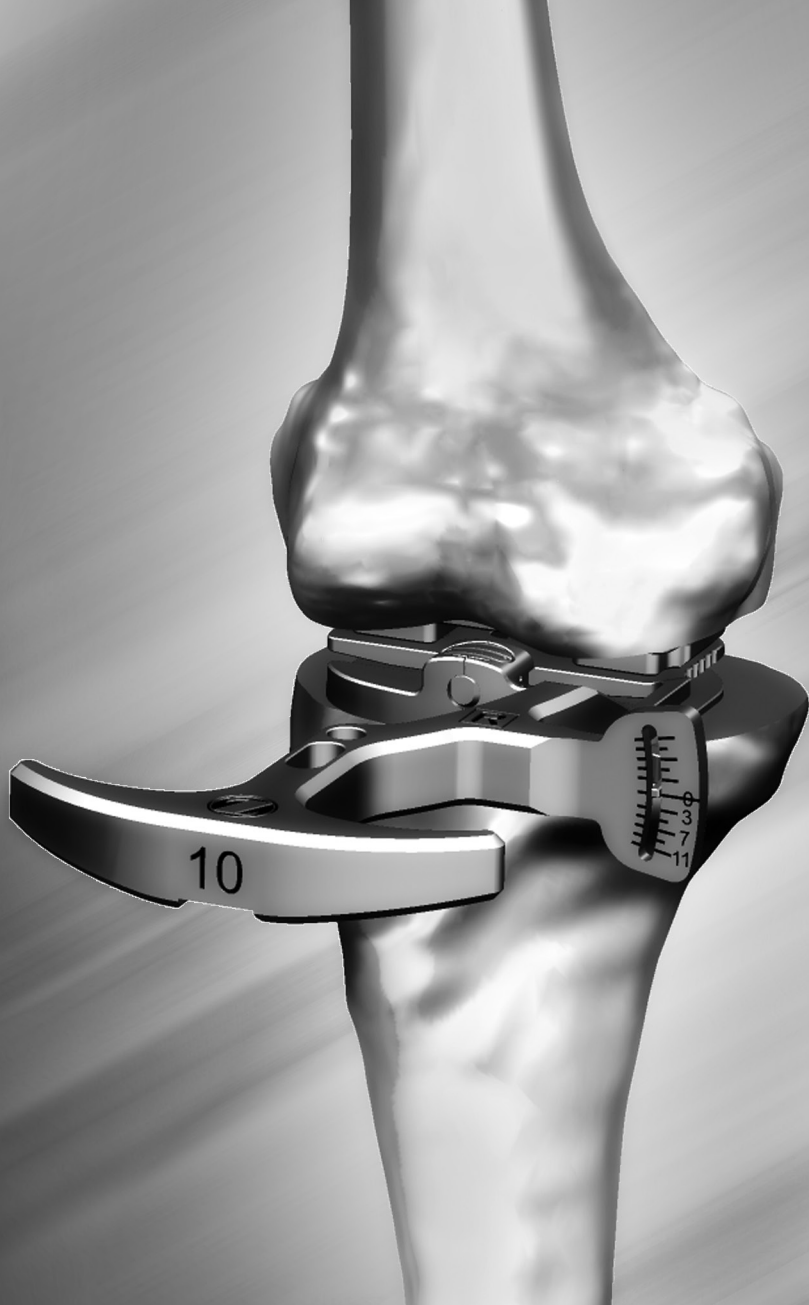

Introduction

Surgical goals during total knee arthroplasty (TKA) include establishment of normal leg alignment, secure implant fixation, and adequate soft tissue balancing and stability. The *Zimmer FuZion* Instruments are designed to help accomplish these goals by providing the surgeon with dynamic ligament feedback, as well as empirical data.

The *Zimmer FuZion* Instruments are based on two platforms: the *Zimmer FuZion* Spacer Block and *Zimmer FuZion* Tensor, and were specifically designed to provide crossover utility, harmonizing measured resection and gap balancing philosophies. This surgical technique describes the use of the *Zimmer FuZion* Instruments in common surgical workflows, used in conjunction with the *Persona*® Primary Instruments.

Surgical Sequence

1. Resect the proximal tibia and the distal femur in preferred order
2. Select the preferred *Zimmer FuZion* instrument platform
3. Use the *Zimmer FuZion* Instruments to establish the joint tension, while evaluating limb alignment in extension and flexion
4. Using the dynamic and empirical data provided by the *Zimmer FuZion* Instruments, select the optimal implant size and position.

**Zimmer FuZion™
Instruments
Surgical Technique****Table Of Contents**

Surgical Workflow Steps	1
Surgical Technique: The Basics	5
Tensor with Zimmer FuZion Sizer	6
Spacer Block with Measured Resection	14
Spacer Block with Zimmer FuZion Sizer	22
Tensor with Gap Referencing Drill Guide	30
Transition from a CR to PS	37
Balancing Matrix	38
Persona Knee Surgical Technique Library	40

Surgical Workflow Steps

Tensor with Zimmer FuZion Sizer

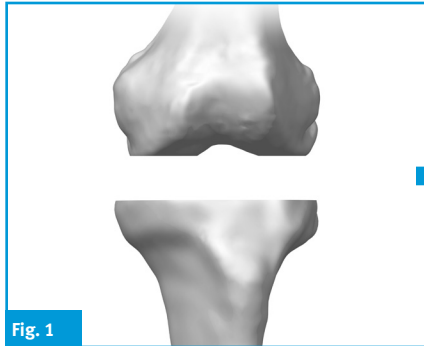

Fig. 1

Resect distal femur and proximal tibia.

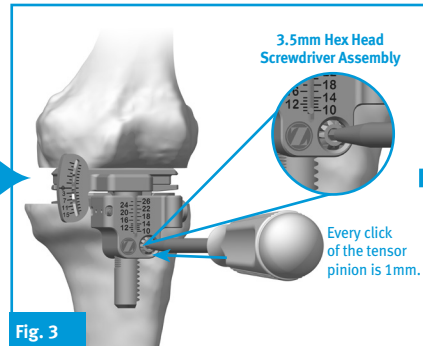

Fig. 3

Measure extension space height & angle.

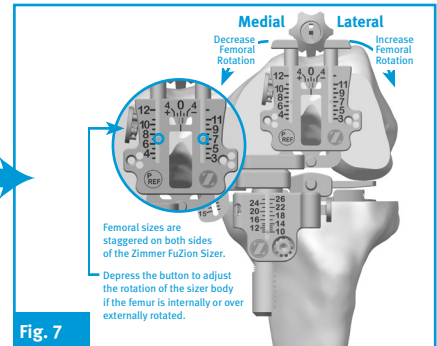

Fig. 7

Establish flexion space, size, set external rotation (drill holes for *Persona* Posterior Referencing 4-in-1 Cut Guide).

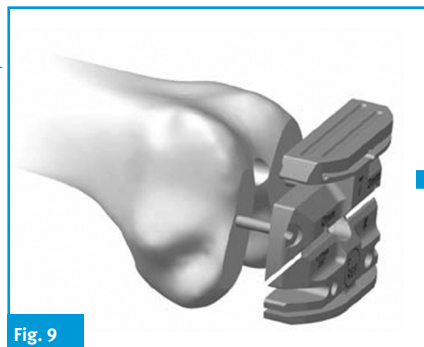

Fig. 9

Place *Persona* Posterior Referencing 4-in-1 Cut Guide on the bone.

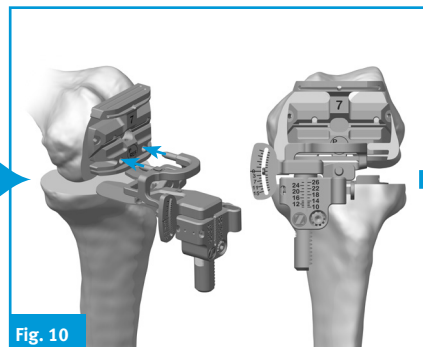

Fig. 10

Double check position of the cut guide with the *Zimmer FuZion* 4-in-1 Adapter.

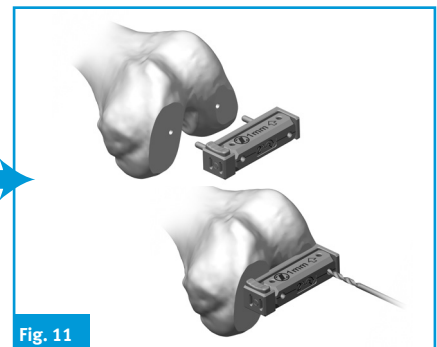

Fig. 11

Optional: Use the shift block to adjust the *Persona* Posterior Referencing 4-in-1 Cut Guide, 1mm anterior or posterior, or 2° internally or externally.



Fig. 12

Check for notching and complete femoral resections.

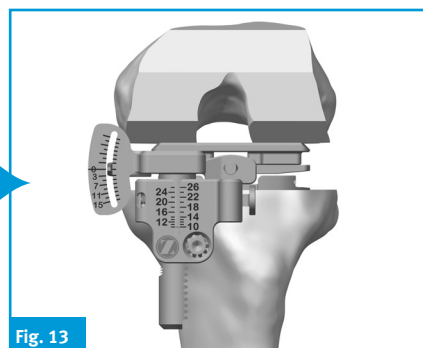

Fig. 13

Verify flexion space and complete procedure.

Spacer Block with Measured Resection

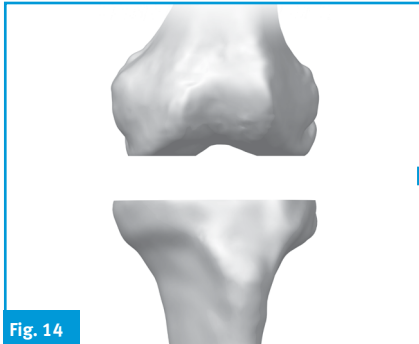

Fig. 14

Resect distal femur and proximal tibia.

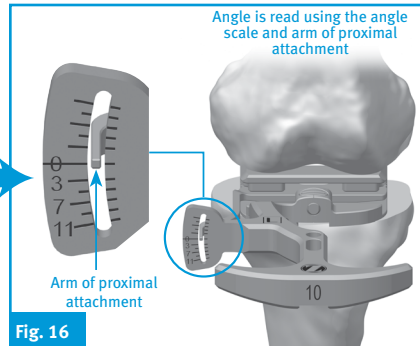

Fig. 16

Measure extension space height & angle.

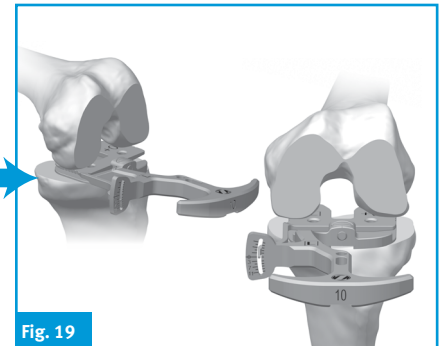

Fig. 19

Measure posterior condylar axis angle under tension relative to the tibia.



Fig. 22

Use *Persona* Posterior Referencing Sizer to size and set rotation.

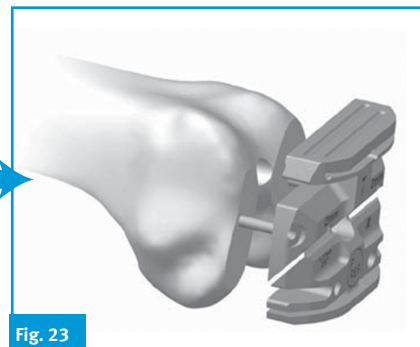

Fig. 23

Place *Persona* Posterior Referencing 4-in-1 Cut Guide on the bone.

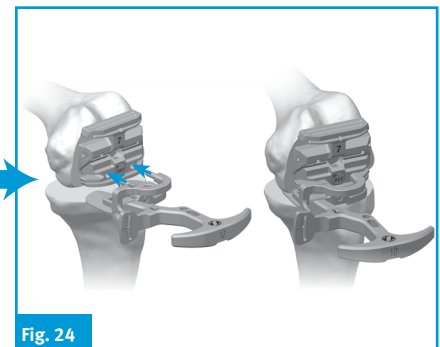

Fig. 24

Double check position of the cut guide with the *Zimmer FuZion* 4-in-1 Adapter

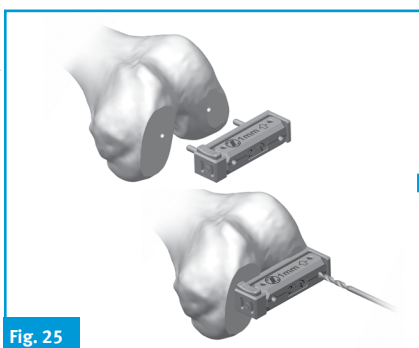

Fig. 25

Optional: Use the shift block to adjust the *Persona* Posterior Referencing 4-in-1 Cut Guide, 1mm anterior or posterior, or 2° internally or externally.

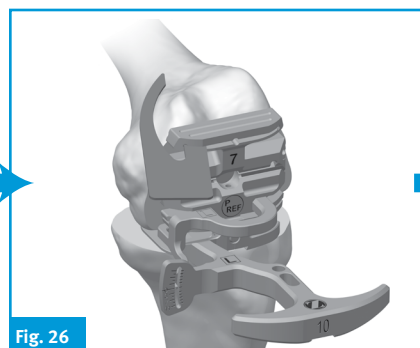

Fig. 26

Check for notching and complete femoral resections.

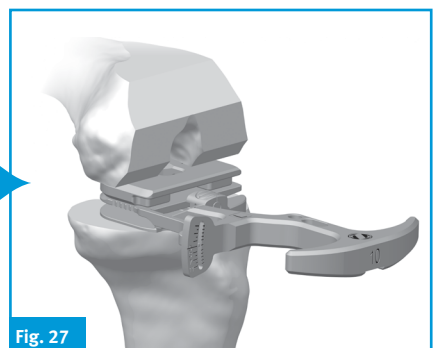

Fig. 27

Verify flexion space and complete procedure.

Spacer Block with Zimmer FuZion Sizer

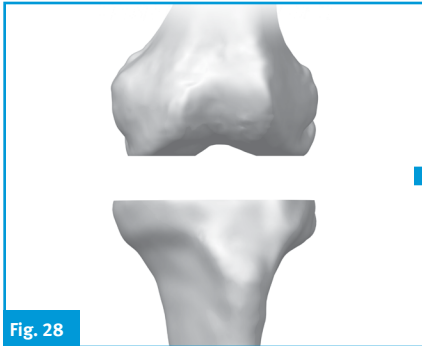

Fig. 28

Resect distal femur and proximal tibia.

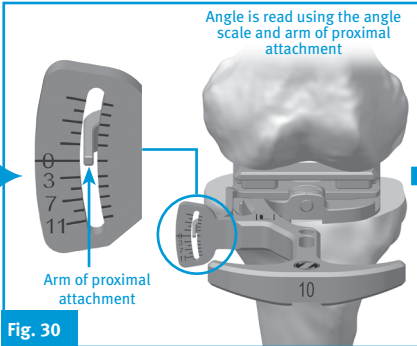

Fig. 30

Measure extension space height & angle.

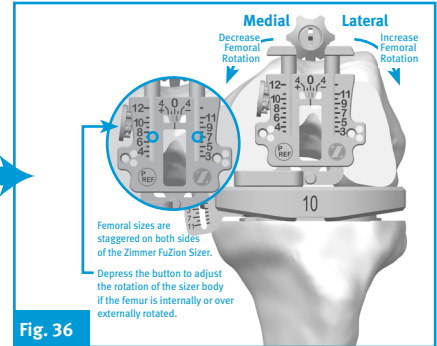

Fig. 36

Establish flexion space, size, set external rotation (drill holes for *Persona* Posterior Referencing 4-in-1 Cut Guide).

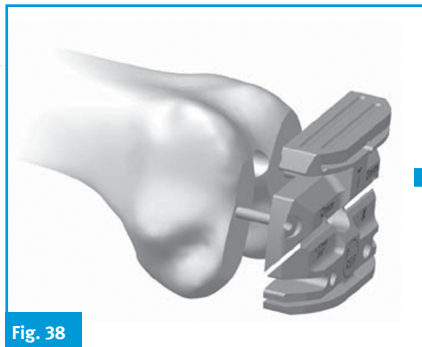

Fig. 38

Place *Persona* Posterior Referencing 4-in-1 Cut Guide on the bone.

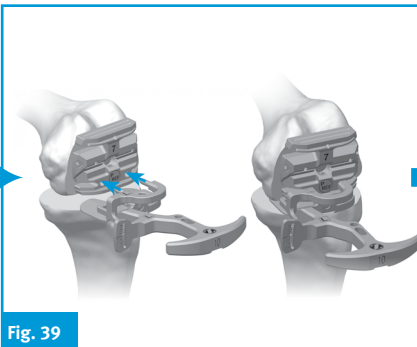

Fig. 39

Double check position of the cut guide with the *Zimmer FuZion* 4-in-1 Adapter.

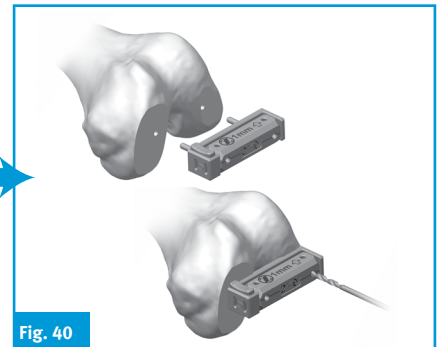

Fig. 40

Optional: Use the shift block to adjust the *Persona* Posterior Referencing 4-in-1 Cut Guide, 1mm anterior or posterior, or 2° internally or externally.

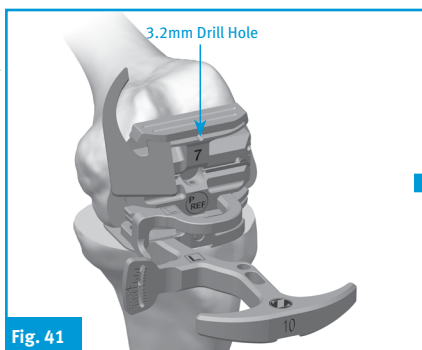

Fig. 41

Check for notching and complete femoral resections.

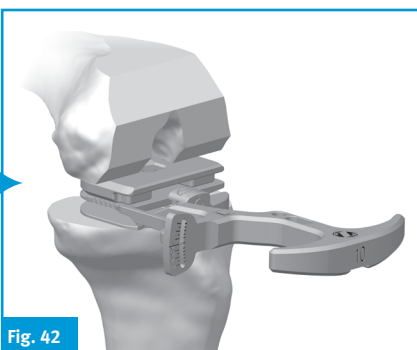

Fig. 42

Verify flexion space and complete procedure.

Tensor with Gap Referencing Drill Guide

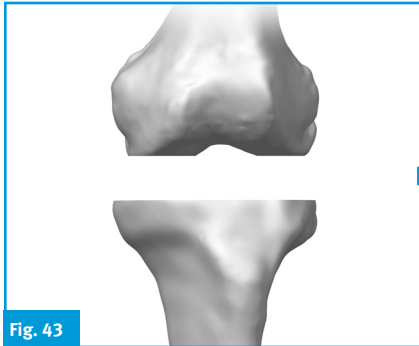

Fig. 43

Resect distal femur and proximal tibia.

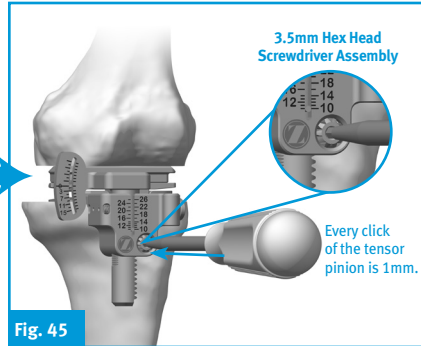

Fig. 45

Measure extension space height & angle.

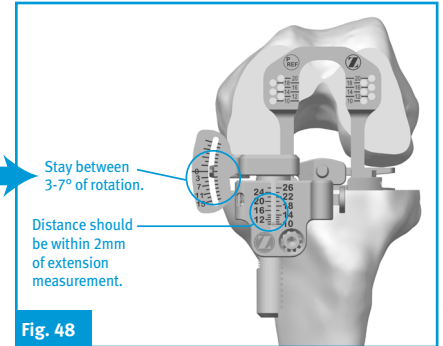

Fig. 48

Establish flexion space and set external rotation (drill holes for *Persona* Posterior Referencing 4-in-1 Cut Guide)



Fig. 51

Size the femur with the *Persona* Posterior Referencing Sizer.
DO NOT DRILL THE HOLES!

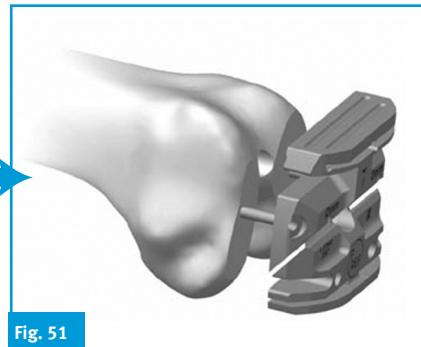

Fig. 51

Place *Persona* Posterior Referencing 4-in-1 Cut Guide on the bone.

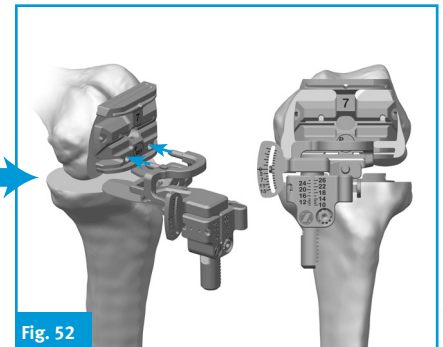

Fig. 52

Double check position of the cut guide with the *Zimmer FuZion* 4-in-1 Adapter.

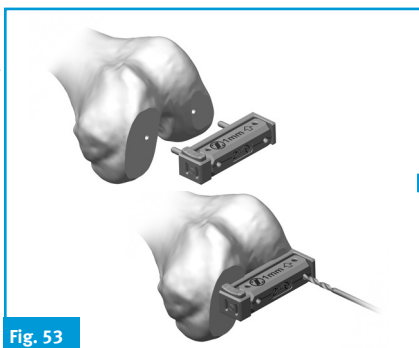

Fig. 53

Optional: Use the shift block to adjust the *Persona* Posterior Referencing 4-in-1 Cut Guide, 1mm anterior or posterior, or 2° internally or externally

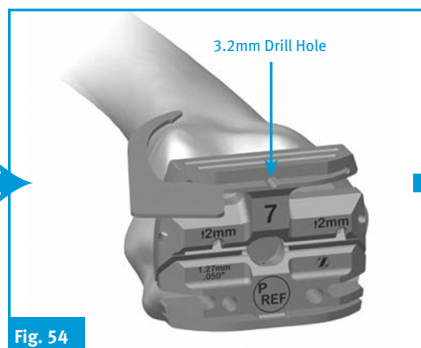

Fig. 54

Check for notching and complete femoral resections.

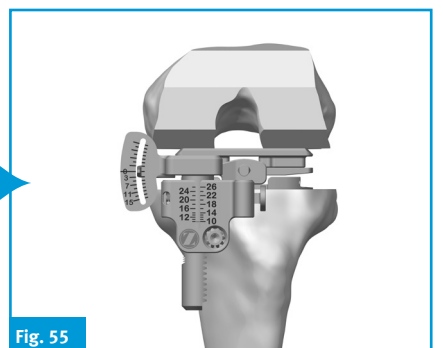

Fig. 55

Verify flexion space and complete procedure.

Surgical Technique: The Basics

The clinical results of Total Knee Arthroplasty (TKA) are dependent on the surgical technique for both posterior cruciate retaining and substituting designs.

The goal of TKA is to reestablish the mechanical axis and restore stability. This is achieved by appropriate bone resection and soft tissue balance. The femoral component should be aligned with the mechanical axis. The tibia should be resected perpendicular to the mechanical axis in the coronal plane. The tibial slope is dictated by the implant design or by the natural slope of the tibia, depending on surgical philosophy.

There are three basic bone cuts in TKA: first, the proximal tibia, which influences the flexion and extension gaps; second the distal femur, which influences the extension gap; and third, the posterior femur, which influences the flexion gap. The more bone resected from the proximal tibia, the thicker the tibial component. Resected distal femoral bone will be replaced by the femoral component. Over-resection may create an extension gap that is larger than the flexion gap, resulting in instability in extension. Under-resection may create a flexion contracture. Resection of the posterior femoral condyle influences the flexion. Over resection relative to the distal femoral resection may result in a larger flexion gap resulting in flexion instability.

A fourth cut, that receives less attention, is the anterior femur, which influences the flexion gap and the patella-femoral joint. The amount of bone resected from the anterior femur is dependent on sizing and the AP position of the resection guide. Under-resection of the anterior femur may be caused by an oversized femoral component or by anterior placement of the correct component with excessive resection of the posterior condyles. This can lead to overstuffing of the patellofemoral joint with possible loss of flexion and increased tension of the anterior soft tissues. Conversely, over-resection of the anterior femur may result in notching of the distal femur. The traditional principles for ligament release state that the tight contracted concave side is released to create a rectangular gap. For a fixed varus deformity, the medial release can include the deep and superficial medial collateral ligament, the semitendinosus tendon and the pes anserinus tendons. Correction of a fixed valgus deformity, the lateral release can include the arcuate complex, iliotibial band, popliteus, and lateral collateral ligament. Following bone resection and soft tissue release the flexion and extension gaps are assessed and should be equal and symmetrical.

References

Scuderi GR. The Basic Principles in Surgical Techniques in Total Knee Arthroplasty. *Knee Arthroplasty Handbook*, Springer NY. 2002; 165 - 167

Note: When assessing femoral rotation and/or tightness it is important to consider:

- Removing retractors or releasing pressure caused by retractors on the surrounding soft tissues.
- Removing the foot from the leg holder to avoid biasing the forces on the joint caused by the tibia's position relative to the femur.
- Ensuring that the flat surfaces of the cut bone are resting completely on the flat surfaces of the spacer block or tensor during assessment and there is no gapping.
- Ensuring the leg is at 90° when evaluating the flexion space.
- Everting the patella and/or a small incision window can laterally bias the flexion assessment.
- While assessing the gap, it is very important to align the spacer block's or tensor's center pivot of the femoral paddle with the center of the knee and the AP Axis of the tibial (medial 1/3 of the tibial tubercle and the anterior insertion of the posterior cruciate).

Magnet Usage:

Warning: Some instruments in the *Zimmer FuZion Instruments* and the *Persona Personalized Knee System* contain magnets. All magnetic instruments should be kept a safe distance from a patient's active implantable medical device(s) (i.e. pacemaker). These types of device may be adversely affected by magnets. Instruments containing magnets should be kept on an appropriate table or stand when not in use at the surgical site.

Tensor with Zimmer FuZion Sizer

1. Perform Distal Femoral and Proximal Tibial Resection (Fig. 1)

- Verify that the cut surface of the tibia is perpendicular to the long axis of the tibia and the valgus angle of the distal femoral cut restores neutral leg alignment. If desired, a drop rod can be used through the alignment hole and/or slot in the tensor.

Note: Osteophytes can impact ligament tension. Ensure all osteophytes are removed prior to assessing soft tissues.

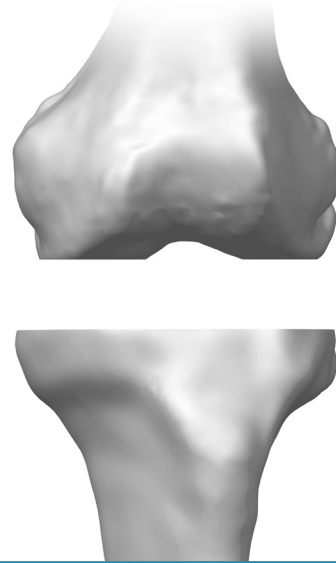

 Fig. 1

2. Extension Gap Assessment and Initial Ligament Balancing

Note: Instruments are left and right specific.

- Remove all the osteophytes and complete the initial ligament balancing. Place the leg in extension. Assemble the *Zimmer FuZion* Tensor with the +9mm Paddle (Fig. 2). Insert the *Zimmer FuZion* Tensor into the extension gap.

Note: Use the +0mm *Zimmer FuZion* Femoral Paddle to evaluate the joint space prior to resection. Attach the +9mm *Zimmer FuZion* Femoral Paddle to the +0mm *Zimmer FuZion* Femoral Paddle (attachment is magnetic) to evaluate the joint space after the femoral condyles have been resected (Fig. 2).

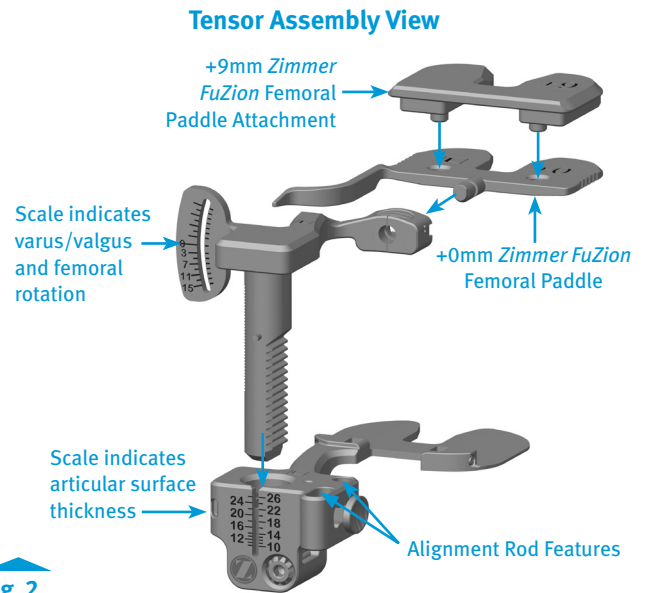

Fig. 2

- Using 3.5mm Hex Head Screwdriver, apply the appropriate amount of force to the tensor to distract the joint (Fig. 3).

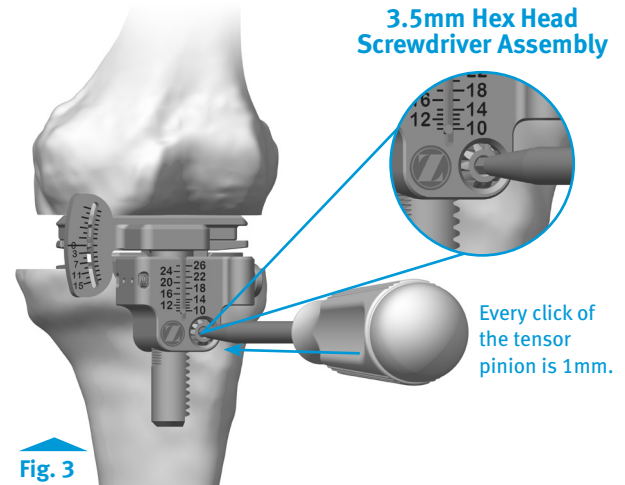

Fig. 3

Instruments



Zimmer FuZion Femoral Paddle, +0mm, Left
42-5097-031-00



Zimmer FuZion Tensor, Femoral Assembly, Left
42-5097-021-00



Zimmer FuZion Tensor, Tibial Assembly, Left
42-5097-021-01



3.5mm Hex Head Screwdriver
00-5120-087-00



Zimmer FuZion Femoral Paddle, +9mm
42-5097-030-09

- The angle scale on the medial side of the instrument should read 0° indicating a rectangular gap. If needed, balance the extension gap using ligament release (Fig. 4).
- After the gap is balanced and rectangular, measure the gap distance using the gap scale on the anterior face of the Zimmer FuZion Tensor (Fig. 4).
- Note the extension gap measurement. It will be used to create the appropriate flexion space.
- While assessing the gap, it is very important to align the tensor's center pivot of the femoral paddle with the center of the knee and the AP Axis of the tibia (medial 1/3 of the tibial tubercle and the anterior insertion of the posterior cruciate) (Fig. 4 & Fig 5).

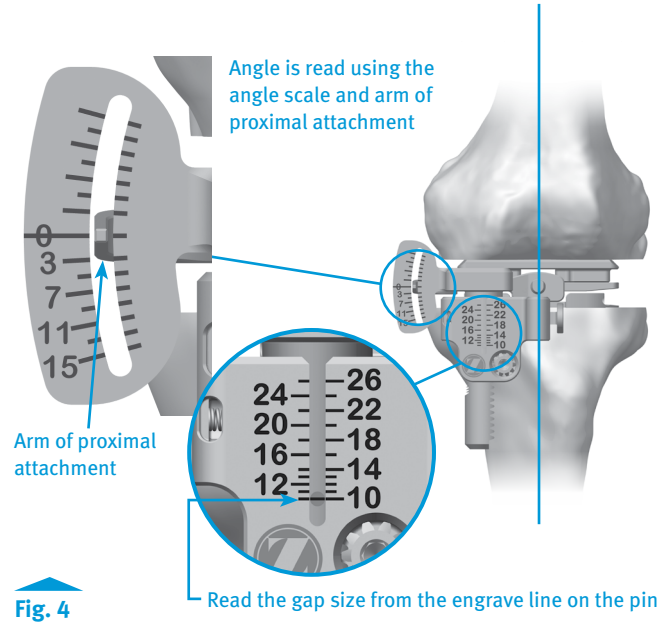

Fig. 4

3. Flexion Gap and Setting Femoral Rotation

- Remove the Zimmer FuZion Tensor from the extension gap. Remove the +9mm Zimmer FuZion Femoral Paddle. Bring the leg into 90° of flexion. Insert the Zimmer FuZion Tensor with the +0mm Zimmer FuZion Femoral Paddle between the cut tibial surface and the uncut posterior condyles, as shown (Fig. 5).
- Using the 3.5mm Hex Head Screwdriver, apply the appropriate amount of force to distract the joint.

Note: The medial collateral ligament will engage first. The femur will then rotate internally, tightening the lateral collateral until equal tension of both is achieved.

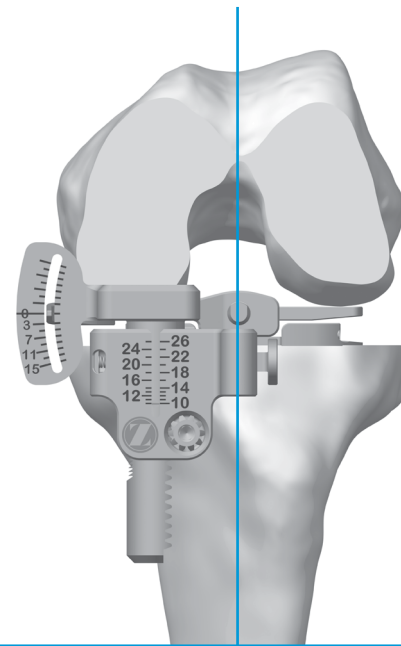

Fig. 5

Instruments



Zimmer FuZion
Femoral Paddle,
+0mm, Left
42-5097-031-00



Zimmer FuZion
Tensor, Femoral
Assembly, Left
42-5097-021-00



Zimmer FuZion
Tensor, Tibial
Assembly, Left
42-5097-021-01



3.5mm Hex Head
Screwdriver
00-5120-087-00



Zimmer FuZion
Femoral Paddle,
+9mm
42-5097-030-09

- Assemble the *Zimmer FuZion Sizer* (Fig. 6).
- Attach the *Zimmer FuZion Sizer* to the proximal face of the *Zimmer FuZion Femoral Assembly*. The wide flat distal face of the *Zimmer FuZion Sizer* will magnetically attach to the *Zimmer FuZion Tensor* (Fig. 6).

Note: The *Zimmer FuZion Sizer* is free to slide in any direction on the proximal surface of the femoral arm.

Note: The *Zimmer FuZion Sizer* can be attached to the *Zimmer FuZion Tensor* after the tensor has been inserted in the joint.

- Slide the *Zimmer FuZion Sizer* up to the distal femur so that the bone side of the *Zimmer FuZion Sizer* is sitting parallel, or flush, with the cut distal surface.

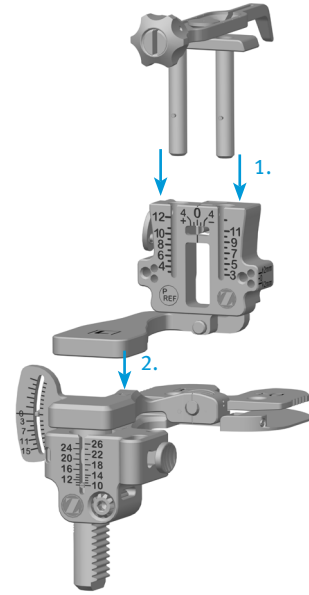

Fig. 6

Zimmer FuZion Sizer magnetically attaches and freely slides into position.

Note: The *Zimmer FuZion Sizer* can be used to adjust the amount of femoral rotation if the natural femur is internally or over externally rotated (Fig. 7). The *Zimmer FuZion Sizer* offers 2° increments of adjustment. Consider adjusting rotation if the scale is outside 3-7° of external rotation. Use Whiteside's line and/or the epicondylar axis as an additional visual reference to confirm component rotation. If the collateral soft-tissue does not provide adequate stability, the surgeon should use his/her professional medical judgment to assess whether a more constraining implant/system or revision implant/system is necessary.

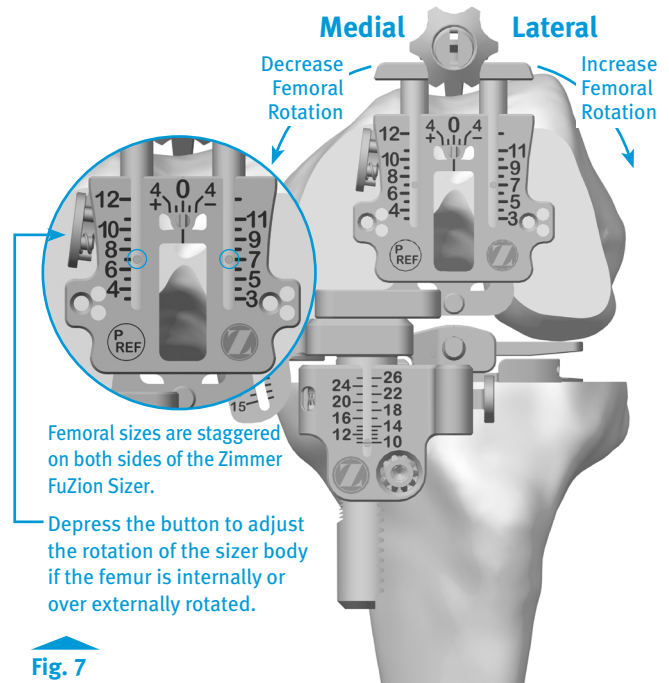

Fig. 7

Instruments



Zimmer FuZion
Posterior Referencing
Sizer Stylus
42-5097-060-10



Zimmer FuZion
Posterior Referencing
Sizer Drill Guide
42-5097-061-00



Zimmer FuZion
Femoral Paddle,
+0mm, Left
42-5097-031-00



Zimmer FuZion
Tensor, Femoral
Assembly, Left
42-5097-021-00

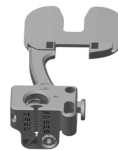

Zimmer FuZion
Tensor, Tibial
Assembly, Left
42-5097-021-01

- Position the tip of the *Zimmer FuZion* Sizer stylus onto the anterior cortex and size the femur (**Fig. 8**).

Caution: If a posterior rough cut is made do not use the angle and gap scales on the *Zimmer FuZion* Tensor.

Note: The *Zimmer FuZion* Sizer can only be used with the *Persona* Posterior Referencing 4-in-1 Cut Guides

- Use the 3.2mm Drill in the drill holes of the *Zimmer FuZion* Sizer to position the *Persona* Posterior Referencing 4-in-1 Cut Guides.
- If needed, use the +2mm/-2mm holes to adjust the flexion space as appropriate (**Fig. 8**).

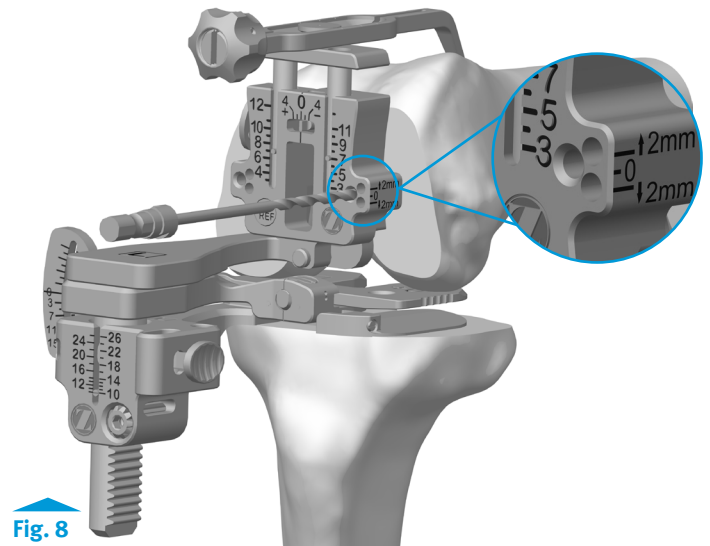

Fig. 8

Instruments



Zimmer FuZion
Posterior Referencing
Sizer Stylus
42-5097-060-10



Zimmer FuZion
Posterior Referencing
Sizer Drill Guide
42-5097-061-00



Zimmer FuZion
Femoral Paddle,
+0mm, Left
42-5097-031-00



Zimmer FuZion
Tensor, Femoral
Assembly, Left
42-5097-021-00



Zimmer FuZion
Tensor, Tibial
Assembly, Left
42-5097-021-01



3.2mm Drill
00-5120-085-00

4. Verify Rotation of Persona 4-in-1 Cut Guide and Ensure No Notching

- Insert the *Persona* Posterior Referencing 4-in-1 Cut Guide (Fig.9).

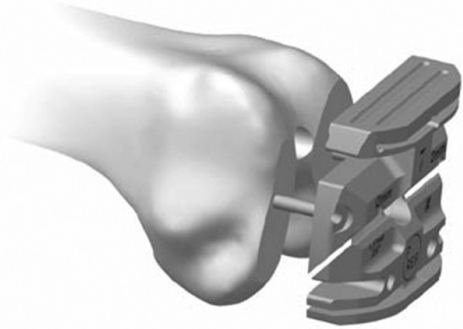

Fig. 9

- Prior to resection of the posterior condyles, attach the *Zimmer FuZion* 4-in-1 Cut Guide Adapter to the *Zimmer FuZion* Tensor and insert into the posterior holes of the *Persona* Posterior Referencing 4-in-1 Cut Guide (Fig. 10).
- Using the 3.5mm Hex Head Screwdriver apply the appropriate amount of force to distract the joint
- Check to ensure the posterior surface of the *Persona* Posterior Referencing 4-in-1 Cut Guide is parallel to the tibia and the angle read out is 0° and flexion gap is appropriate based on what was measured in extension.

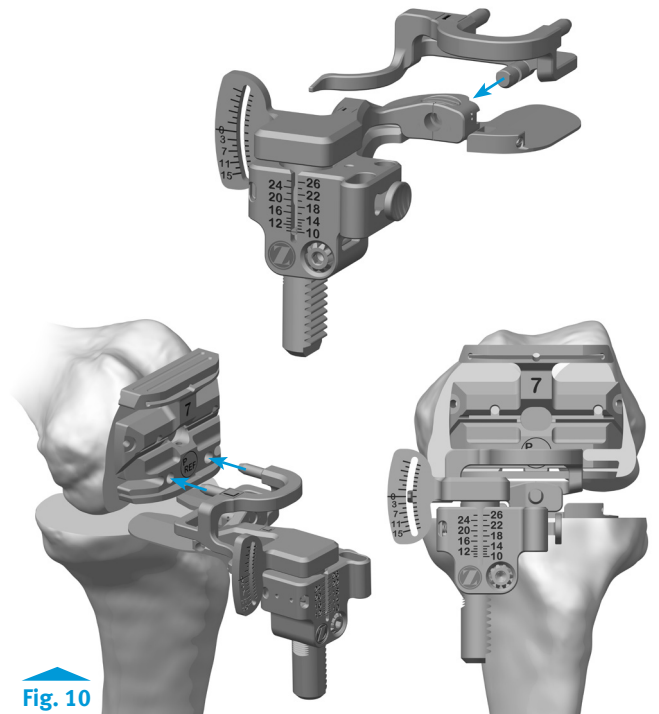

Fig. 10

Instruments



Zimmer FuZion
Tensor, Femoral
Assembly, Left
42-5097-021-00



Zimmer FuZion
Tensor, Tibial
Assembly, Left
42-5097-021-01

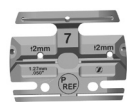

Persona Posterior
Referencing 4-in-1
Cut Guide - Size 7
42-5099-044-62



Zimmer FuZion
4-in-1 Cut Guide
Adapter, Left
42-5097-041-00



3.2mm Drill
00-5120-085-00



3.5mm Hex Head
Screwdriver
00-5120-087-00

- If needed, use the *Persona* Shift Block to adjust the *Persona* Posterior Referencing 4-in-1 Cut Guide rotation (2°) or AP position (1mm) prior to making any cuts with the *Persona* Posterior Referencing 4-in-1 Cut Guide. Place the pegs of the *Persona* Shift Block in the holes created by the *Zimmer FuZion* Sizer for the *Persona* Posterior Referencing 4-in-1 Cut Guide. Establish the new block position by drilling through the holes on the face of the *Persona* Shift Block that specifies the adjustment that is intended. Use a 3.2mm Drill to drill the holes. Remove the shift block (Fig. 11). Place the *Persona* Posterior Referencing 4-in-1 Cut Guide on the bone. Use the *Zimmer FuZion* 4-in-1 Cut Guide Adapter to verify the *Persona* Posterior Referencing 4-in-1 Cut Guide's new position is correct.

Caution: Be sure to put the *Persona* Posterior Referencing 4-in-1 Cut Guide in the new holes created by the *Persona* Shift Block.

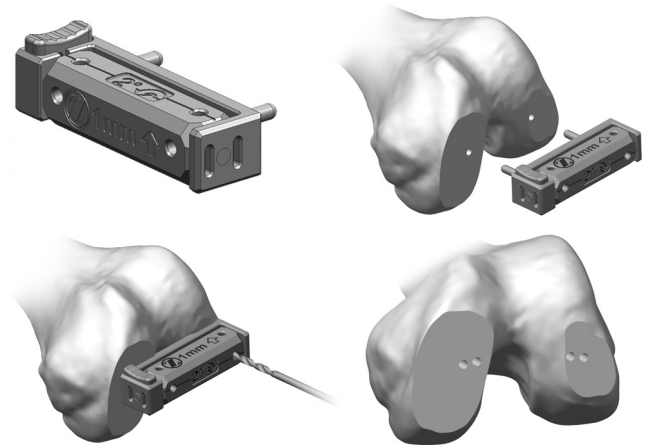

Persona Shift Block

Fig. 11

- Check for notching by placing a resection guide in the anterior cut slot or by using a 3.2mm Drill in the drill hole in the anterior cut slot of the *Persona* Posterior Referencing 4-in-1 Cut Guide before making cuts. Change size as appropriate to avoid notching (Fig. 12).



Fig. 12

Instruments



Persona Posterior Referencing 4-in-1 Cut Guide - Size 7
42-5099-044-62



3.2mm Drill
00-5120-085-00



Persona Shift Block
42-5099-085-10



Resection Guide
00-5977-084-00

5. Check Flexion Gap

Note: The +9mm *Zimmer FuZion* Femoral Paddle can be attached to the *Zimmer FuZion* +0mm Femoral Paddle and used with the *Zimmer FuZion* Tensor to check the flexion gap after resection (**Fig. 13**).

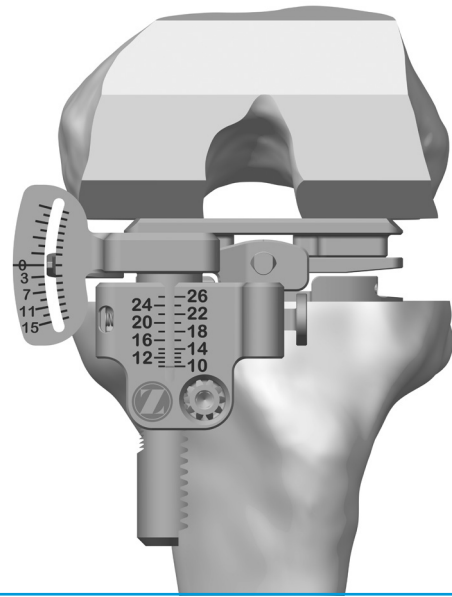

Fig. 13

6. Complete Procedure

- Use *Persona* Primary Instruments to complete the procedure.

Instruments



Zimmer FuZion
Tensor, Femoral
Assembly, Left
42-5097-021-00



Zimmer FuZion
Tensor, Tibial
Assembly, Left
42-5097-021-01



Zimmer FuZion
Femoral Paddle,
+0mm, Left
42-5097-031-00



Zimmer FuZion
Femoral Paddle,
+9mm
42-5097-030-09

Spacer Block with Measured Resection

1. Perform Distal Femoral and Proximal Tibial Resection (Fig. 14)

- Verify that the cut surface of the tibia is perpendicular to the long axis of the tibia and that the valgus angle of the distal femoral cut restores neutral leg alignment. If desired, a drop rod can be used through the alignment hold and/or slot in the spacer block.

Note: Osteophytes can impact ligament tension. Ensure all osteophytes are removed prior to assessing soft tissues.

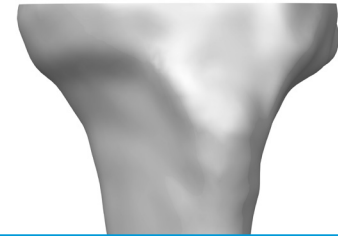
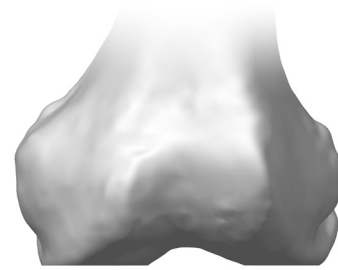

Fig. 14

2. Extension Gap Assessment and Initial Ligament Balancing

Note: Instruments are left and right specific.

- Remove all the osteophytes and complete the initial ligament balancing. Place the leg in extension. Assemble the *Zimmer FuZion* Spacer Block (Fig. 15). Insert the *Zimmer FuZion* Spacer Block into the extension gap (Fig. 16).
- While assessing the gap, it is very important to align the spacer block's center pivot of the femoral paddle with the center of the knee and the AP Axis of the tibial (medial 1/3 of the tibial tubercle and the anterior insertion of the posterior cruciate) (Fig. 16).

Note: Use the +0mm *Zimmer FuZion* Femoral Paddle to evaluate the joint space prior to resection. Add the +9mm *Zimmer FuZion* Femoral Paddle to the +0mm *Zimmer FuZion* Femoral Paddle (attachment is magnetic) to evaluate the joint space after femoral condyles have been resected (Fig. 15).

- Zimmer FuZion* Shims can be added to bottom of *Zimmer FuZion* Spacer Block to increase the construct thickness and achieve the proper joint tension (Fig. 15).
- Zimmer FuZion* Shims are available for 11, 12, 13, 14, 16, 18, and 20mm construct thicknesses (default thickness of spacer block is 10mm) (Fig. 15).
- The angle scale is on the medial side of the instrument should read 0° indicating a rectangular gap. If needed, balance the extension gap using ligament release (Fig. 16).
- Note the *Zimmer FuZion* Spacer Block construct thickness. It will be used to create the appropriate flexion space.

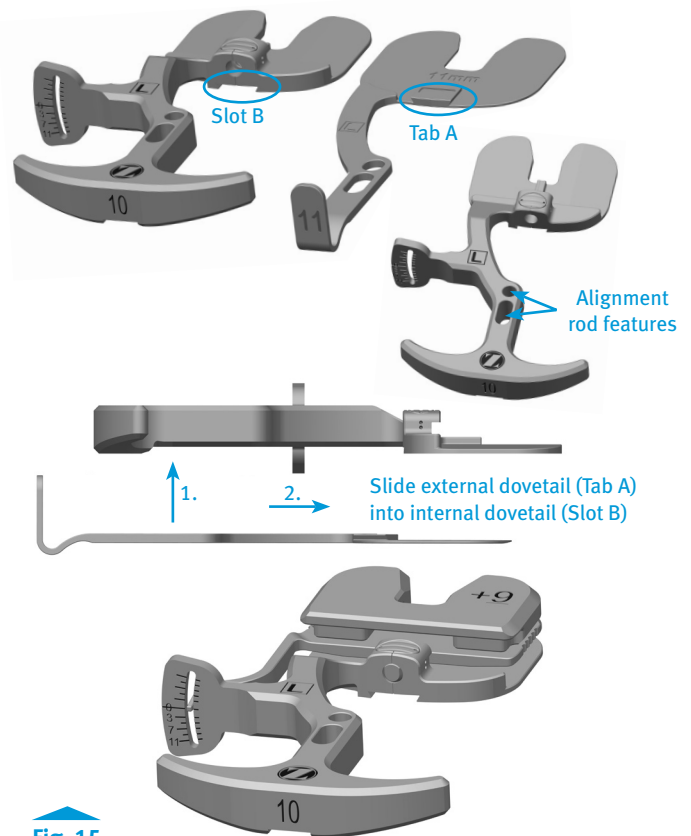

Fig. 15

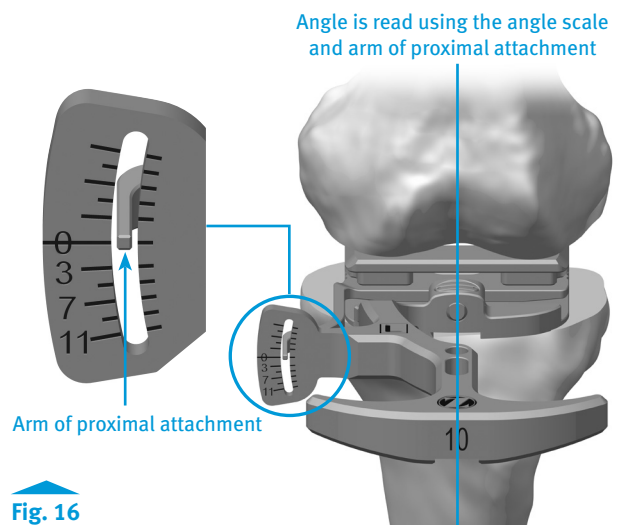

Fig. 16

Instruments



Zimmer FuZion
Spacer Block,
Left
42-5097-011-00



Zimmer FuZion
Femoral Paddle,
+0mm, Left
42-5097-031-00



Zimmer FuZion
Spacer Block
Shim, 11mm, Left
42-5097-011-11



Zimmer FuZion
Femoral Paddle,
+9mm
42-5097-030-09

- The *Zimmer FuZion* Spacer Block can be used as a conventional solid spacer block. The femoral paddle rotation can be locked at 0°, in both +0mm and +9mm configurations, by pushing the femoral paddle towards the t-handle (**Fig. 17**).

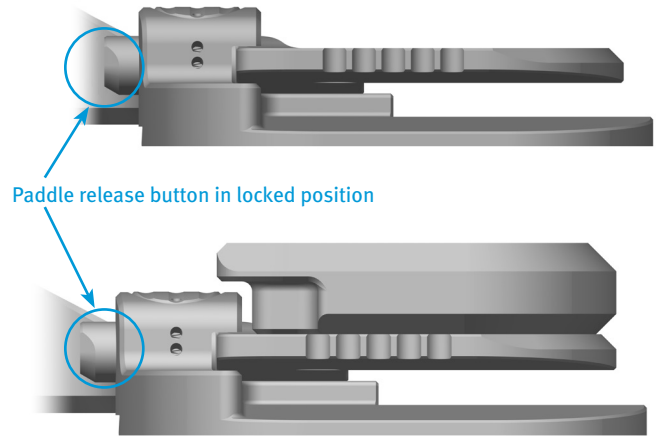
**Fig. 17**

Side view: +0mm Paddle in the locked position (top)

Side view: +9mm Paddle in the locked position (bottom)

- To release, simply push the button created by the femoral paddle when in the lock position until it is flush with the face of the spacer (**Fig. 18**).

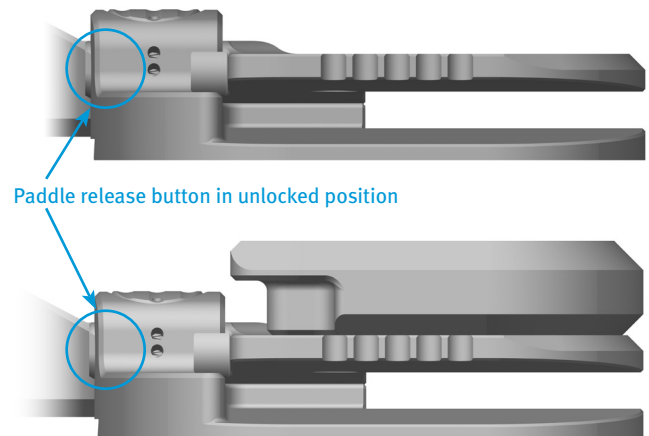
**Fig. 18**

Side view: +0mm Paddle in the unlocked position (top)

Side view: +9mm Paddle in the unlocked position (bottom)

Instruments

Zimmer FuZion
Spacer Block,
Left

42-5097-011-00



Zimmer FuZion
Femoral Paddle,
+0mm, Left

42-5097-031-00



Zimmer FuZion
Femoral Paddle,
+9mm

42-5097-030-09

3. Size Femur and Set External Rotation

- Remove the *Zimmer FuZion* Spacer Block from the extension gap. Disassemble the *Zimmer FuZion* +9mm Femoral Paddle from *Zimmer FuZion* +0mm Femoral Paddle. Bring the leg into 90° of flexion. Insert the *Zimmer FuZion* Spacer Block between the cut tibial surface and the uncut posterior condyles, as shown (Fig. 19).
- Zimmer FuZion* Shims can be added to the bottom of the *Zimmer FuZion* Spacer Block to increase the construct thickness and achieve the proper joint tension.
- Zimmer FuZion* Shims are available for 11, 12, 13, 14, 16, 18, and 20mm construct thicknesses (default thickness of spacer is 10mm).
- Ensure that the posterior condyles are contacting the flat surfaces of the medial and lateral sides of the femoral paddle, that the tibial paddle is sitting flush against the tibial surface and that joint is tensed. Read the angle in the angle display. If the angle is in the positive portion of the angle display, set your *Persona* Posterior Referencing Sizer to that angle (external rotation). If the scale is in the negative portion of the angle display (portion of the angle scale without numbers) the medial compartment is opening wider than the lateral and the appropriate steps should be made to insure a rectangular flexion space when the posterior resection is made (Fig. 19). If the collateral soft-tissue does not provide adequate stability, the surgeon should use his/her professional medical judgment to assess whether a more constraining implant/system or revision implant/system is necessary.
- Assemble the Posterior Referencing Sizer Boom with the Posterior Referencing Sizer (Fig. 20). Establish the initial external rotation setting by holding the body (silver portion) of the sizer in one hand, positioning the opposite index finger behind the “L” or “R” with the thumb over the “L” or “R”, squeeze, adjust to desired setting and release (Fig. 21). External rotation can be set at 0°, 3°, 5°, 7°, or 9° left or right.

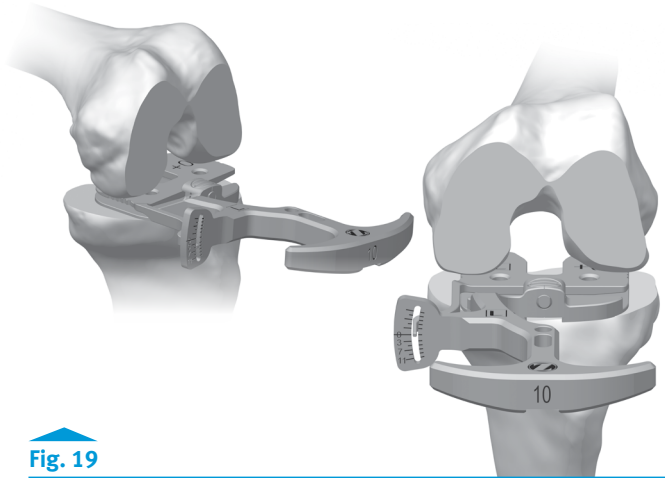

Fig. 19

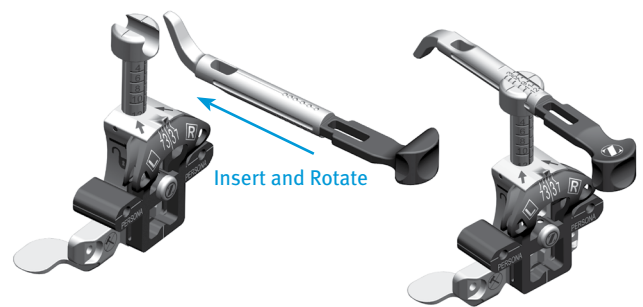

Fig. 20

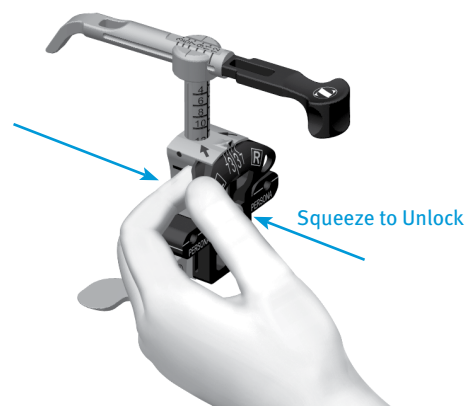

Fig. 21

Instruments



Persona Posterior Referencing Sizer
42-5099-040-00



Persona Posterior Referencing Sizer Boom
42-5099-040-10



Zimmer FuZion Spacer Block, Left
42-5097-011-00



Zimmer FuZion Femoral Paddle, +0mm, Left
42-5097-031-00



Zimmer FuZion Femoral Paddle, +9mm
42-5097-030-09

- Refer to *Persona* The Personalized Knee System Posterior Referencing Surgical Technique (97-5026-081-00) for instructions and feature highlights of the Posterior Referencing Sizer and 4-in-1 Cut Guides.
- The *Persona* Posterior Referencing Sizer is used to size and set rotation without the spacer block in this step (Fig. 22).

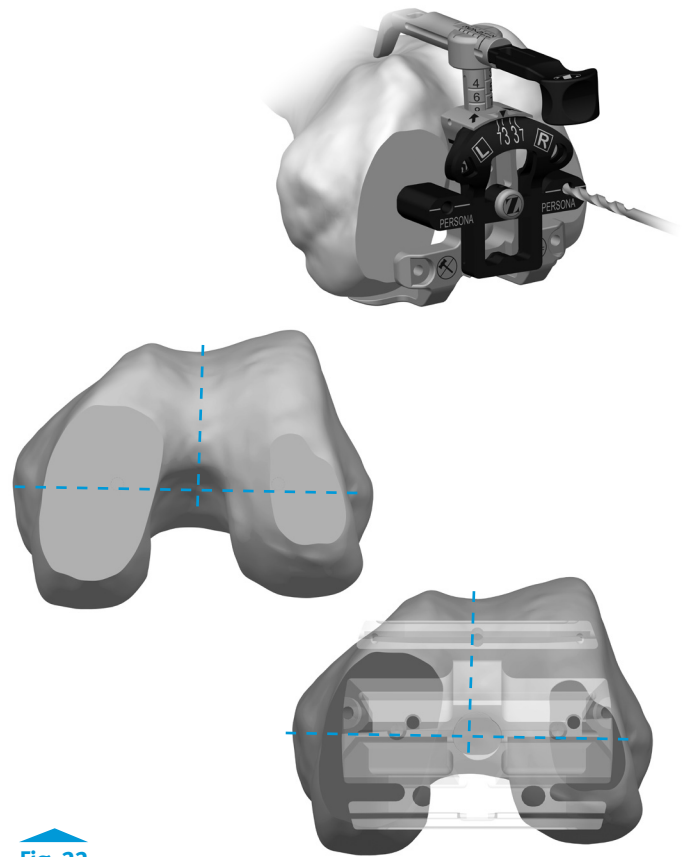

Fig. 22

- Insert the *Persona* Posterior Referencing 4-in-1 Cut Guide (Fig. 23).

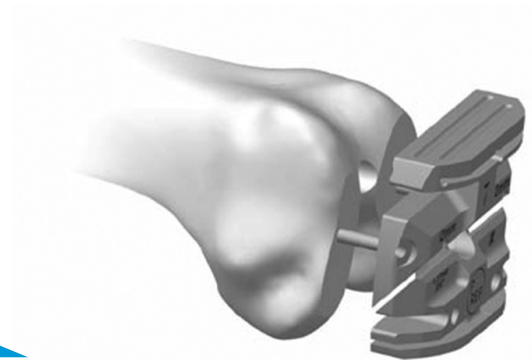
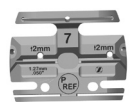
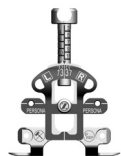

Fig. 23

Instruments



Persona Posterior Referencing 4-in-1 Cut Guide - Size 7
42-5099-044-62



Persona Posterior Referencing Sizer
42-5099-040-00



Persona Posterior Referencing Sizer Boom
42-5099-040-10

4. Verify Rotation of the Persona 4-in-1 Cut Guide and Ensure No Notching.

- Prior to resection of the posterior condyles, attach the *Zimmer FuZion* 4-in-1 Cut Guide Adapter to the *Zimmer FuZion* Spacer Block and insert into the posterior holes of the *Persona* Posterior Referencing 4-in-1 Cut Guide (Fig. 24).
- *Zimmer FuZion* Shims can be added to bottom of spacer block to increase the construct thickness and achieve the proper joint tension.
- *Zimmer FuZion* Shims are available for 11, 12, 13, 14, 16, 18, and 20mm construct thickness (default thickness of spacer block is 10mm).
- Check to ensure the posterior surface of the *Persona* Posterior Referencing 4-in-1 Cut Guide is parallel to the tibia, the angle read out is 0°, and the flexion gap is appropriate based on what was measured in extension.
- If needed, use the *Persona* Shift Block to adjust the *Persona* Posterior Referencing 4-in-1 Cut Guide rotation (2°) or AP position (1mm) prior to making any cuts with the *Persona* Posterior Referencing 4-in-1 Cut Guide. Place the pegs of the *Persona* Shift Block in the holes created by the *Zimmer FuZion* Sizer for the *Persona* Posterior Referencing 4-in-1 Cut Guide. Establish the new block position by drilling through the holes on the face of the *Persona* Shift Block that specifies the adjustment that is intended. Use a 3.2mm Drill to drill the holes (Fig. 25). Use the *Zimmer FuZion* 4-in-1 Cut Guide Adapter to verify the *Persona* Posterior Referencing 4-in-1 Cut Guide's new position is correct.

Caution: Be sure to put the *Persona* Posterior Referencing 4-in-1 Cut Guide in the new holes created by the *Persona* Shift Block.

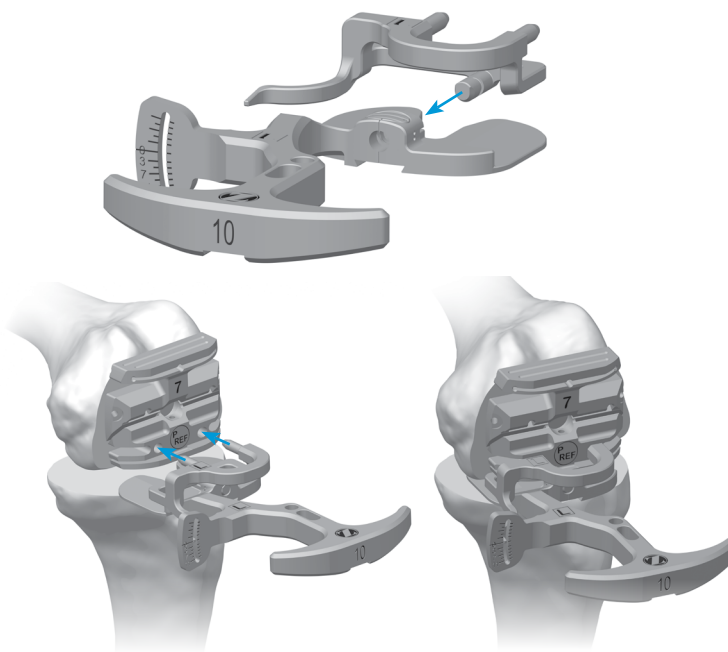

Fig. 24

Zimmer FuZion 4-in-1 Cut Guide Adapter

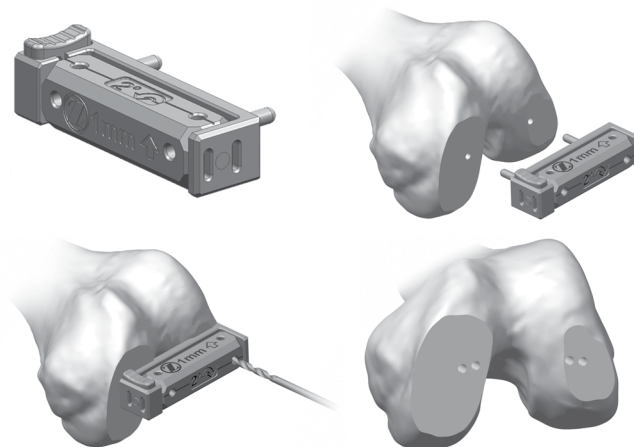
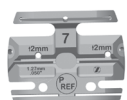

Fig. 25

Persona Shift Block

Instruments



Persona Posterior Referencing 4-in-1 Cut Guide - Size 7
42-5099-044-62



Zimmer FuZion Spacer Block, Left
42-5097-011-00



Zimmer FuZion Spacer Block Shim, 11mm, Left
42-5097-011-11



Persona Shift Block
42-5099-085-10



Zimmer FuZion 4-in-1 Cut Guide Adapter, Left
42-5097-041-00



3.2mm Drill
00-5120-085-00

- Check for notching by placing a resection guide in the anterior cut slot or by using a 3.2mm Drill in the drill hole in the anterior cut slot of the *Persona* Posterior Referencing 4-in-1 Cut Guide before making cuts. Change size as appropriate to avoid notching (**Fig. 26**).

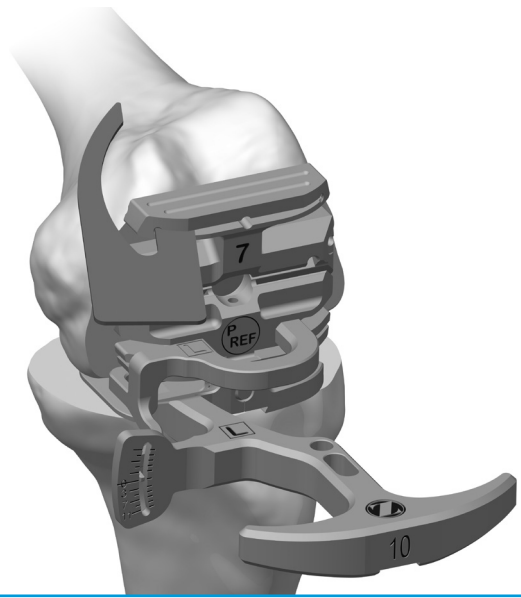

Fig. 26

Instruments



Persona Posterior Referencing 4-in-1 Cut Guide - Size 7
42-5099-044-62



Zimmer FuZion Spacer Block, Left
42-5097-011-00



Zimmer FuZion Spacer Block Shim, 11mm, Left
42-5097-011-11



Zimmer FuZion 4-in-1 Cut Guide Adapter, Left
42-5097-041-00



Resection Guide
00-5977-084-00



3.2mm Drill
00-5120-085-00

5. Check the Flexion Space

- The +9mm *Zimmer FuZion* Femoral Paddle can be attached to the *Zimmer FuZion* +0mm Femoral Paddle and used with the *Zimmer FuZion* Spacer Block to check the flexion gap after resection (**Fig. 27**).

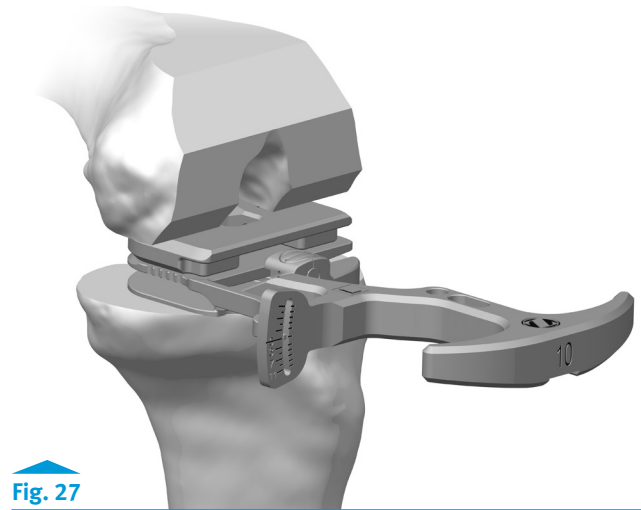

6. Complete Procedure

- Use *Persona* Primary Instruments to complete the procedure.

Instruments



Zimmer FuZion
Spacer Block,
Left
42-5097-011-00



Zimmer FuZion
Femoral Paddle,
+0mm, Left
42-5097-031-00



Zimmer FuZion
Femoral Paddle,
+9mm
42-5097-030-09

Spacer Block with Zimmer FuZion Sizer

1. Perform Distal Femoral and Proximal Tibial Resection (Fig. 28)

- Verify that the cut surface of the tibia is perpendicular to the long axis of the tibia and that the valgus angle of the distal femoral cut restores neutral leg alignment. If desired, a drop rod can be used through the alignment hole and/or slot in the spacer block.

Note: Osteophytes can impact ligament tension. Ensure all osteophytes are removed prior to assessing soft tissues.

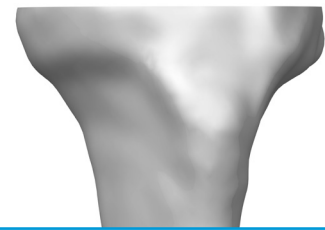
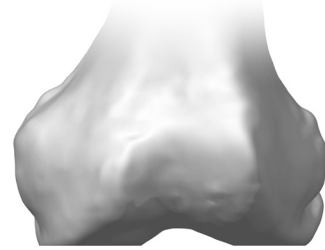

Fig. 28

2. Extension Gap Assessment and Initial Ligament Balancing

Note: Instruments are left and right specific.

- Remove all the osteophytes and complete the initial ligament balancing. Place the leg in extension. Assemble the *Zimmer FuZion* Spacer Block (Fig. 29). Insert the *Zimmer FuZion* Spacer Block into the extension gap (Fig. 30).
- While assessing the gap, it is very important to align the spacer block's center pivot of the femoral paddle with the center of the knee and the AP Axis of the tibial (medial 1/3 of the tibial tubercle and the anterior insertion of the posterior cruciate) (Fig. 30).

Note: Use the +0mm *Zimmer FuZion* Femoral Paddle to evaluate the joint space prior to resection. Add the +9mm *Zimmer FuZion* Femoral Paddle to the +0mm *Zimmer FuZion* Femoral Paddle (attachment is magnetic) to evaluate the joint space after femoral condyles have been resected (Fig. 29).

- Zimmer FuZion* Shims can be added to bottom of *Zimmer FuZion* Spacer Block to increase the construct thickness and achieve the proper joint tension (Fig. 29).
- Zimmer FuZion* Shims are available for 11, 12, 13, 14, 16, 18, and 20mm construct thicknesses (default thickness of spacer block is 10mm) (Fig. 29).
- The angle scale is on the medial side of the instrument should read 0° indicating a rectangular gap. If needed, balance the extension gap using ligament release (Fig. 30).
- Note the *Zimmer FuZion* Spacer Block construct thickness. It will be used to create the appropriate flexion space.

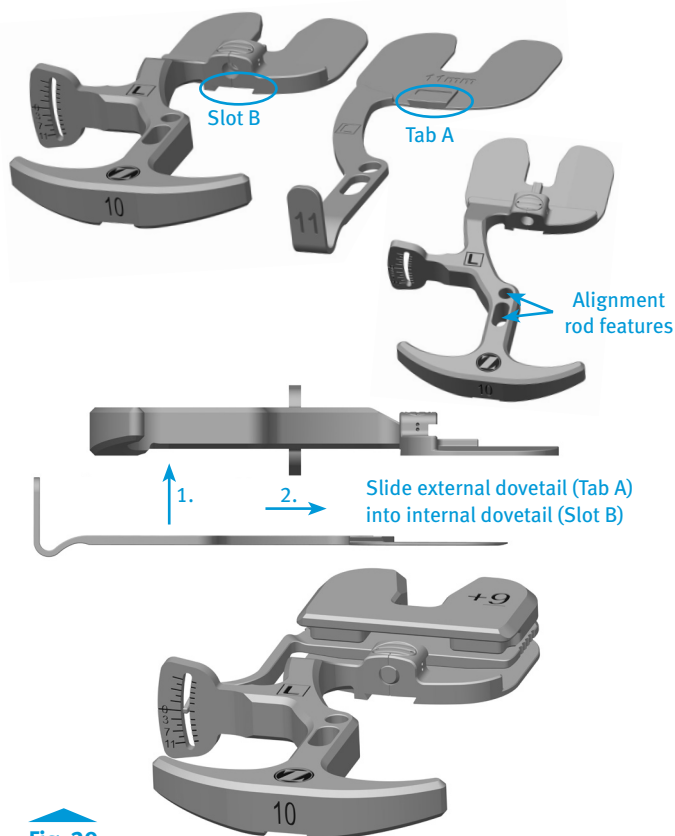

Fig. 29

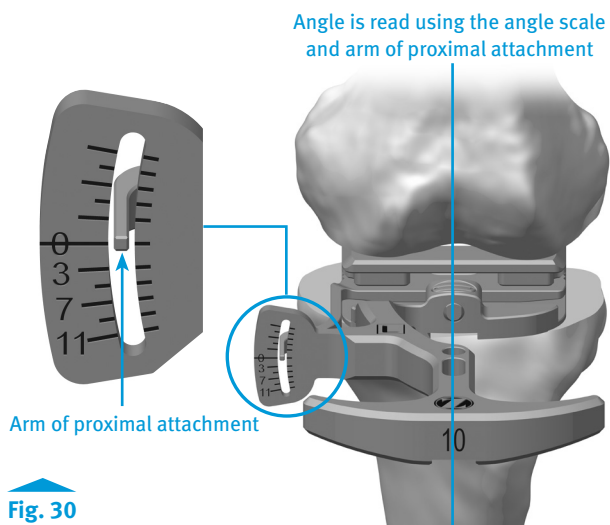

Fig. 30

Instruments



Zimmer FuZion
Spacer Block,
Left
42-5097-011-00



Zimmer FuZion
Femoral Paddle,
+0mm, Left
42-5097-031-00



Zimmer FuZion
Spacer Block
Shim, 11mm, Left
42-5097-011-11



Zimmer FuZion
Femoral Paddle,
+9mm
42-5097-030-09

- The *Zimmer FuZion* Spacer Block can be used as a conventional solid spacer block. The femoral paddle rotation can be locked at 0°, in both +0mm and +9mm configurations, by pushing the femoral paddle towards the t-handle (**Fig. 31**).

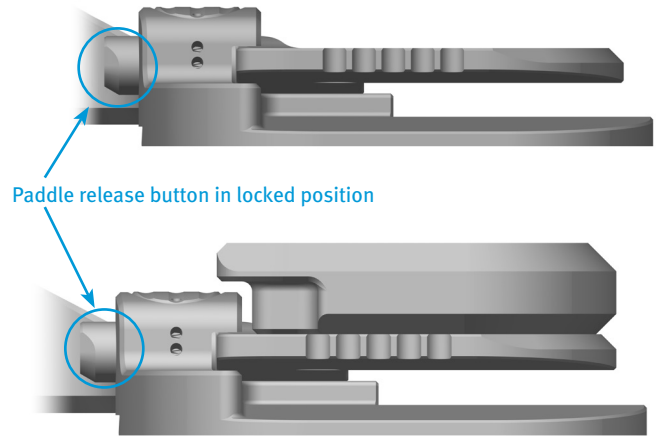
**Fig. 31**

Side view: +0mm Paddle in the locked position (top)

Side view: +9mm Paddle in the locked position (bottom)

- To release, simply push the button created by the femoral paddle when it is in the lock position until it is flush with the face of the spacer (**Fig. 32**).

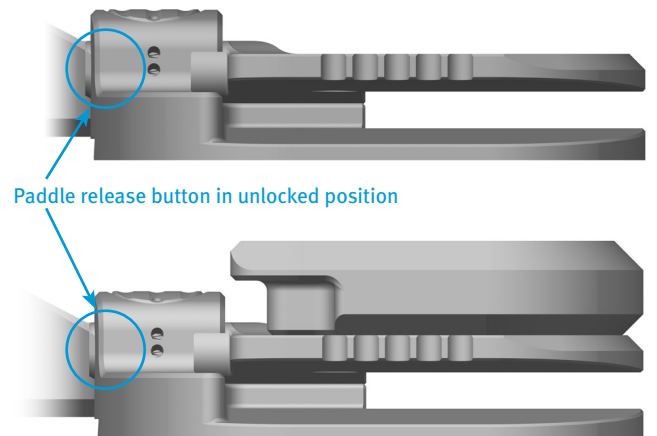
**Fig. 32**

Side view: +0mm Paddle in the unlocked position (top)

Side view: +9mm Paddle in the unlocked position (bottom)

Instruments

Zimmer FuZion
Spacer Block,
Left
42-5097-011-00



Zimmer FuZion
Femoral Paddle,
+0mm, Left
42-5097-031-00



Zimmer FuZion
Femoral Paddle,
+9mm
42-5097-030-09

3. Flexion Gap and Setting Femoral Rotation

- Remove the *Zimmer FuZion* Spacer Block from the extension gap. Disassemble the *Zimmer FuZion* +9mm Femoral Paddle from *Zimmer FuZion* +0mm Femoral Paddle. Bring the leg into 90° of flexion. Insert the *Zimmer FuZion* Spacer Block between the cut tibial surface and the uncut posterior condyles, as shown (Fig. 33).
- Zimmer FuZion* Shims can be added to the bottom of the *Zimmer FuZion* Spacer Block to increase the construct thickness and achieve the proper joint tension.
- Zimmer FuZion* Shims are available for 11, 12, 13, 14, 16, 18, and 20mm construct thicknesses (default thickness of spacer block is 10mm).

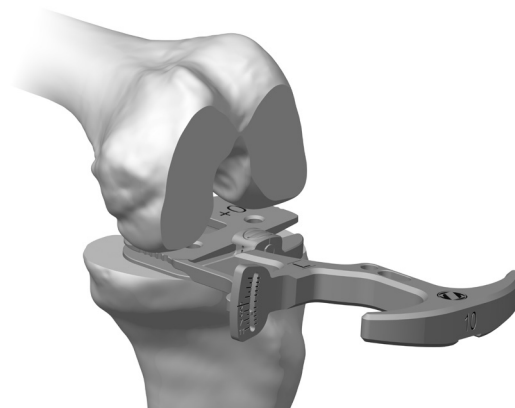

Fig. 33

- Assemble *Zimmer FuZion* Sizer. Attach the *Zimmer FuZion* Sizer to the proximal face of the *Zimmer FuZion* Spacer Block. The wide flat distal face of the *Zimmer FuZion* Sizer will magnetically attach to the *Zimmer FuZion* Spacer Block (Fig. 34).

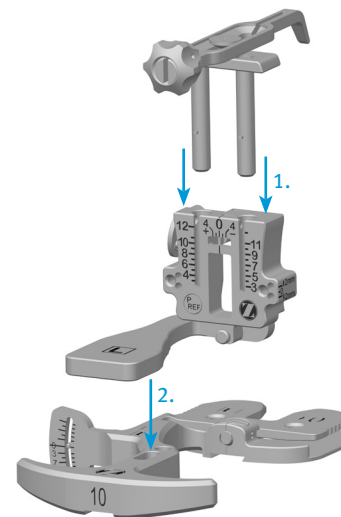

Fig. 34

Zimmer FuZion Sizer magnetically attaches and freely slides into position.

Instruments



Zimmer FuZion
Posterior Referencing
Sizer Stylus
42-5097-060-10

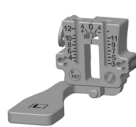

Zimmer FuZion
Posterior Referencing
Sizer Drill Guide
42-5097-061-00



Zimmer FuZion
Spacer Block,
Left
42-5097-011-00



Zimmer FuZion
Femoral Paddle,
+0mm, Left
42-5097-031-00



Zimmer FuZion
Spacer Block Shim,
11mm, Left
42-5097-011-11

Note: The *Zimmer FuZion Sizer* is free to slide in any direction on the proximal surface of the spacer block.

- Slide the *Zimmer FuZion Sizer* up to the distal femur so that the bone side of the *Zimmer FuZion Sizer* is sitting parallel, or flush, with the cut distal surface.
- Position the tip of the *Zimmer FuZion Sizer* stylus onto the anterior cortex and size the femur (**Fig. 35**).

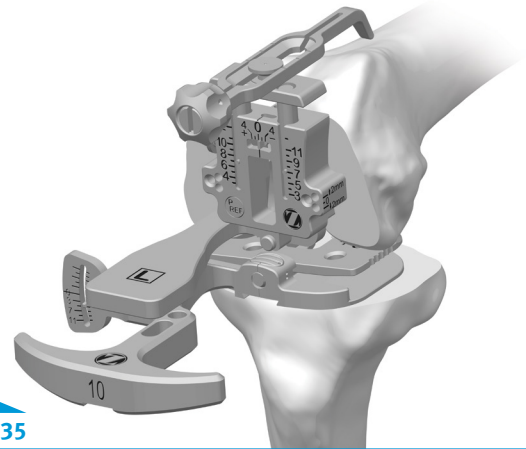

Fig. 35

Note: The *Zimmer FuZion Sizer* can be used to adjust the amount of femoral rotation if the natural femur is internally or over externally rotated (**Fig. 36**). The *Zimmer FuZion Sizer* offers 2° increments of adjustment. Consider adjusting rotation if the scale is outside 3-7° of external rotation. Use Whiteside's line and/or the epicondylar axis as an additional visual reference to confirm component rotation. If the collateral soft-tissue does not provide adequate stability, the surgeon should use his/her professional medical judgment to assess whether a more constraining implant/system or revision implant/system is necessary.

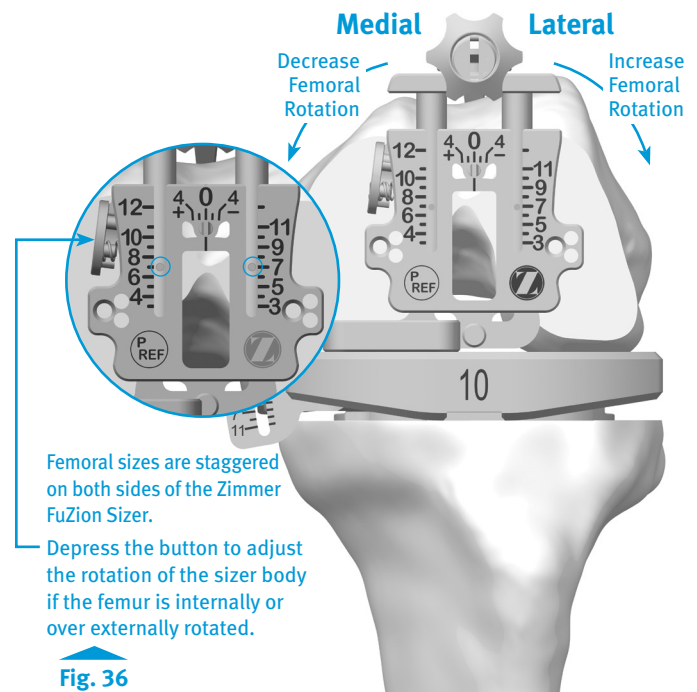

Fig. 36

Instruments



Zimmer FuZion
Posterior Referencing
Sizer Stylus
42-5097-060-10



Zimmer FuZion
Posterior Referencing
Sizer Drill Guide
42-5097-061-00



Zimmer FuZion
Spacer Block,
Left
42-5097-011-00



Zimmer FuZion
Femoral Paddle,
+0mm, Left
42-5097-031-00

Caution: If a posterior rough cut is made do not use the angle and gap scales on the *Zimmer FuZion* Spacer Block.

Note: The *Zimmer FuZion* Sizer can only be used with the *Persona* Posterior Referencing 4-in-1 Cut Guides

- Use the 3.2mm Drill in the drill holes of the *Zimmer FuZion* Sizer to position the Posterior Referencing 4-in-1 Cut Guides.
- If needed, use the +2mm/-2mm holes to adjust the flexion space as appropriate (Fig. 37).

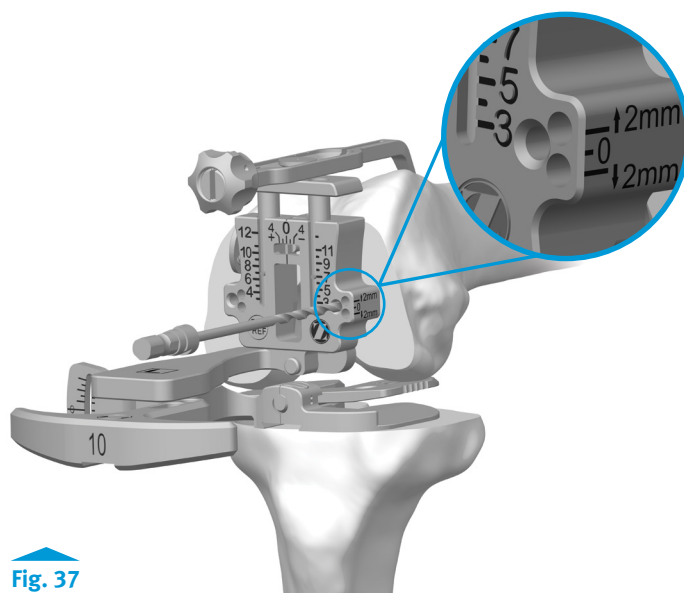

Fig. 37

- Remove *Zimmer FuZion* Spacer Block and Sizer.
- Insert *Persona* Posterior Referencing 4-in1 Cut Guide (Fig. 38).

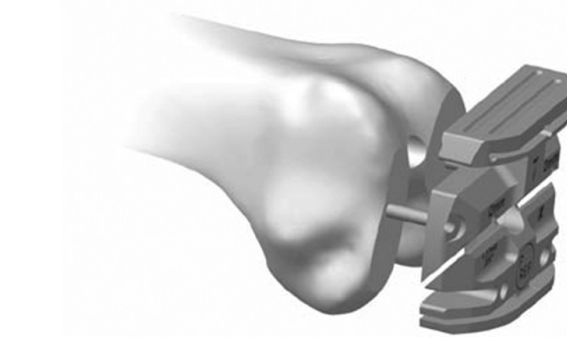
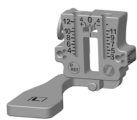

Fig. 38

Instruments



Zimmer FuZion
Posterior Referencing
Sizer Stylus
42-5097-060-10



Zimmer FuZion
Posterior Referencing
Sizer Drill Guide
42-5097-061-00



Zimmer FuZion
Spacer Block,
Left
42-5097-011-00



Zimmer FuZion
Femoral Paddle,
+0mm, Left
42-5097-031-00



Persona Posterior
Referencing 4-in-1
Cut Guide - Size 7
42-5099-044-62



3.2mm Drill
00-5120-085-00

4. Verify Rotation of Persona 4-in-1 Cut Guide and Ensure No Notching

- Prior to resection of the posterior condyles, attach the Zimmer FuZion 4-in-1 Cut Guide Adapter to the Zimmer FuZion Spacer Block and insert into the posterior holes of the Persona Posterior Referencing 4-in-1 Cut Guide (Fig. 39).
- Zimmer FuZion Shims can be added to bottom of spacer block to increase the construct thickness and achieve the proper joint tension.
- Zimmer FuZion Shims are available for 11, 12, 13, 14, 16, 18, and 20mm construct thicknesses (default thickness of spacer block is 10mm).
- Check to ensure the posterior surface of the Persona Posterior Referencing 4-in-1 Cut Guide is parallel to the tibia and the angle read out is 0° and flexion gap (articular surface thickness) is appropriate based on what was measured in extension.
- If needed, use the Persona Shift Block to adjust the Persona Posterior Referencing 4-in-1 Cut Guide rotation (2°) or AP position (1mm) prior to making any cuts with the Persona Posterior Referencing 4-in-1 Cut Guide (Fig. 40). Place the pegs of the Persona Shift Block in the holes created by the Zimmer FuZion Sizer for the Persona Posterior Referencing 4-in-1 Cut Guide. Establish the new block position by drilling through the holes on the face of the Persona Shift Block that specifies the adjustment that is intended. Use a 3.2mm Drill to drill the holes. Use the Zimmer FuZion 4-in-1 Cut Guide Adapter to verify the Persona Posterior Referencing 4-in-1 Cut Guide's new position is correct.

Caution: Be sure to put the Persona Posterior Referencing 4-in-1 Cut Guide in the new holes created by the Persona Shift Block.

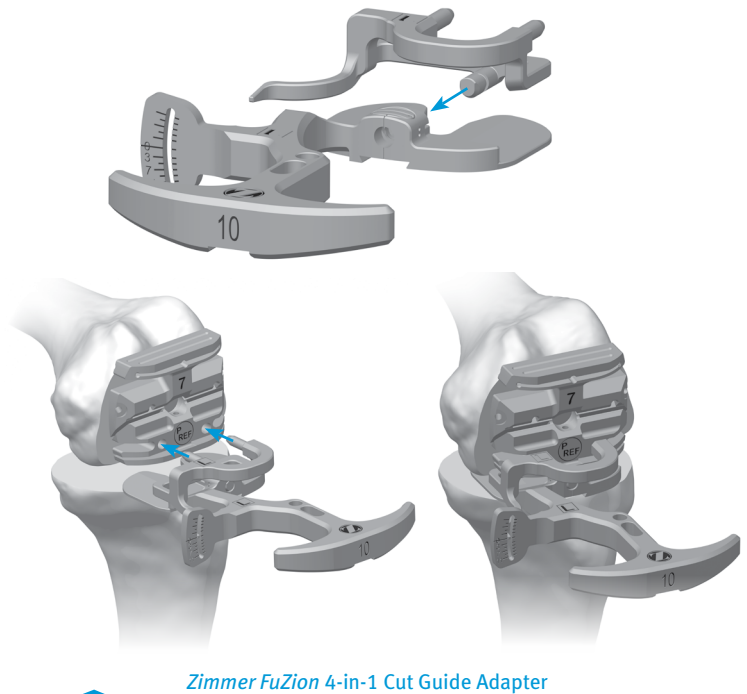

Fig. 39

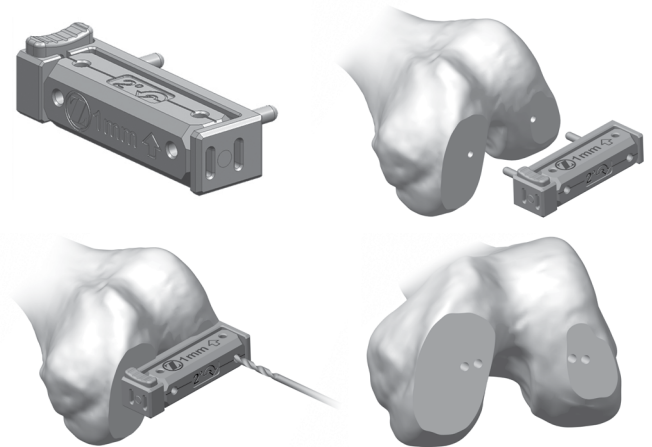
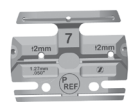

Fig. 40

Instruments



Persona Posterior Referencing 4-in-1 Cut Guide - Size 7
42-5099-044-62



Zimmer FuZion Spacer Block, Left
42-5097-011-00



Zimmer FuZion Spacer Block Shim, 11mm, Left
42-5097-011-11



Persona Shift Block
42-5099-085-10



Zimmer FuZion 4-in-1 Cut Guide Adapter, Left
42-5097-041-00



3.2mm Drill
00-5120-085-00

- Check for notching by placing a resection guide in the anterior cut slot or by using a 3.2mm Drill in the drill hole in the anterior cut slot of the *Persona* Posterior Referencing 4-in-1 Cut Guide before making cuts. Change size as appropriate to avoid notching (Fig. 41).

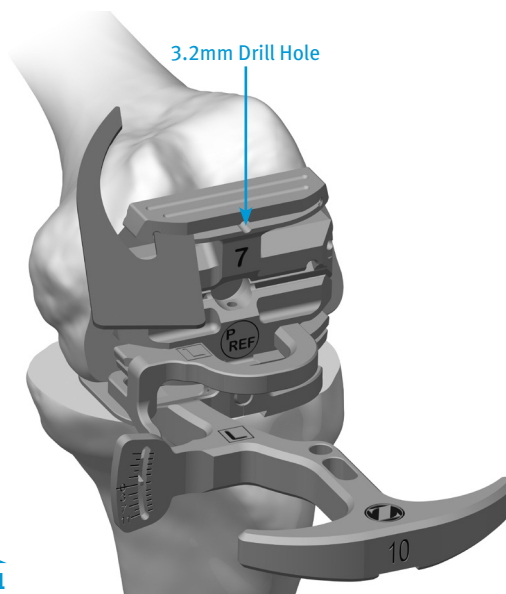

Fig. 41

Check the Flexion Space

- The +9mm *Zimmer FuZion* Femoral Paddle can be attached to the *Zimmer FuZion* +0mm Femoral Paddle and used with the *Zimmer FuZion* Spacer Block to check the flexion gap after resection (Fig. 42).

5. Complete Procedure

- Use *Persona* Primary Instruments to complete the procedure.

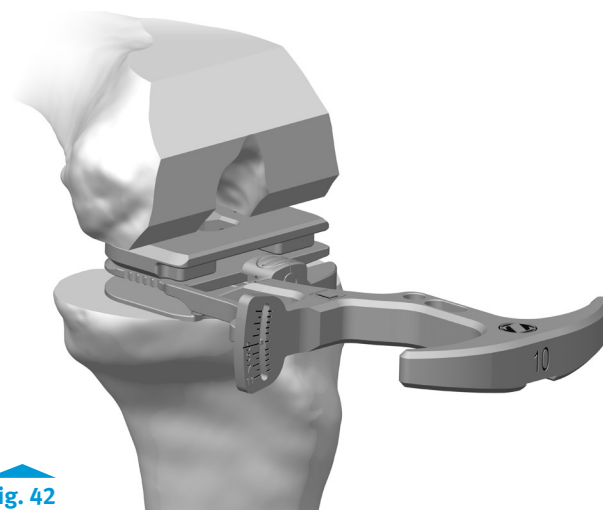

Fig. 42

Instruments



Zimmer FuZion
Spacer Block,
Left
42-5097-011-00



Zimmer FuZion
Femoral Paddle,
+0mm, Left
42-5097-031-00



Zimmer FuZion
Femoral Paddle,
+9mm
42-5097-030-09



Resection Guide
00-5977-084-00



3.2mm Drill
00-5120-085-00

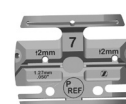

Persona Posterior
Referencing
4-in-1 Cut Guide
- Size 7
42-5099-044-62



Zimmer FuZion
4-in-1 Cut Guide
Adapter, Left
42-5097-041-00

Tensor with Gap Referencing Drill Guide

1. Perform Distal Femoral and Proximal Tibial Resection (Fig. 43)

- Verify that the cut surface of the tibia is perpendicular to the long axis of the tibia and the valgus angle of the distal femoral cut restores neutral leg alignment. If desired, a drop rod can be used through the alignment hole and/or slot in the tensor.

Note: Osteophytes can impact ligament tension. Ensure all osteophytes are removed prior to assessing soft tissues.

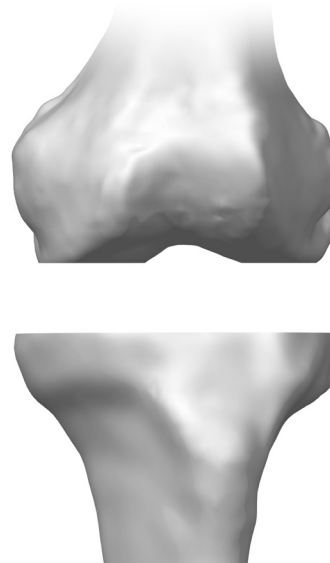

 Fig. 43

2. Extension Gap Assessment and Initial Ligament Balancing

Note: Instruments are left and right specific.

- Remove all the osteophytes and complete the initial ligament balancing. Place the leg in extension. Assemble the *Zimmer FuZion* Tensor with the +9mm Paddle (Fig. 44). Insert the *Zimmer FuZion* Tensor into the extension gap.

Note: Use the +0mm *Zimmer FuZion* Femoral Paddle to evaluate the joint space prior to resection. Attach the +9mm *Zimmer FuZion* Femoral Paddle to the +0mm *Zimmer FuZion* Femoral Paddle (attachment is magnetic) to evaluate the joint space after the femoral condyles have been resected (Fig. 44).

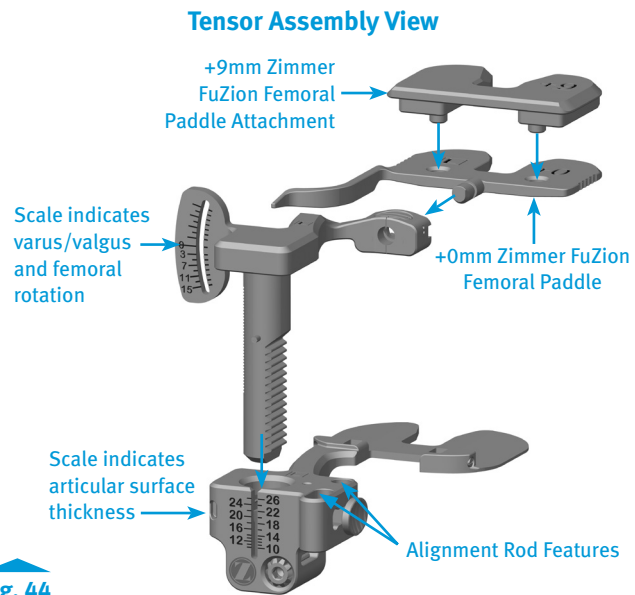

Fig. 44

- Using 3.5mm Hex Head Screwdriver, apply the appropriate amount of force to the tensor to distract the joint (Fig 45).

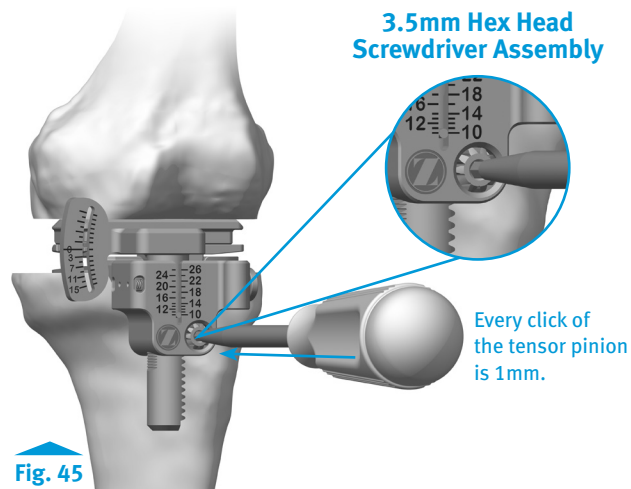

Fig. 45

Instruments



Zimmer FuZion
Femoral Paddle,
+0mm, Left
42-5097-031-00



Zimmer FuZion
Tensor, Femoral
Assembly, Left
42-5097-021-00



Zimmer FuZion
Tensor, Tibial
Assembly, Left
42-5097-021-01



3.5mm Hex Head
Screwdriver
00-5120-087-00



Zimmer FuZion
Femoral Paddle,
+9mm
42-5097-030-09

- While assessing the gap, it is very important to align the tensor's center pivot of the femoral paddle with the center of the knee and the AP Axis of the tibia (medial 1/3 of the tibial tubercle and the anterior insertion of the posterior cruciate) (**Fig. 46 & Fig. 48**).
- The angle scale on the medial side of the instrument should read 0° indicating a rectangular gap. If needed, balance the extension gap using ligament release (**Fig. 46**).
- After the gap is balanced and rectangular, measure the gap distance using the gap scale on the anterior face of the *Zimmer FuZion* Tensor (**Fig. 46**).
- Note the extension gap measurement. It will be used to create the appropriate flexion space.

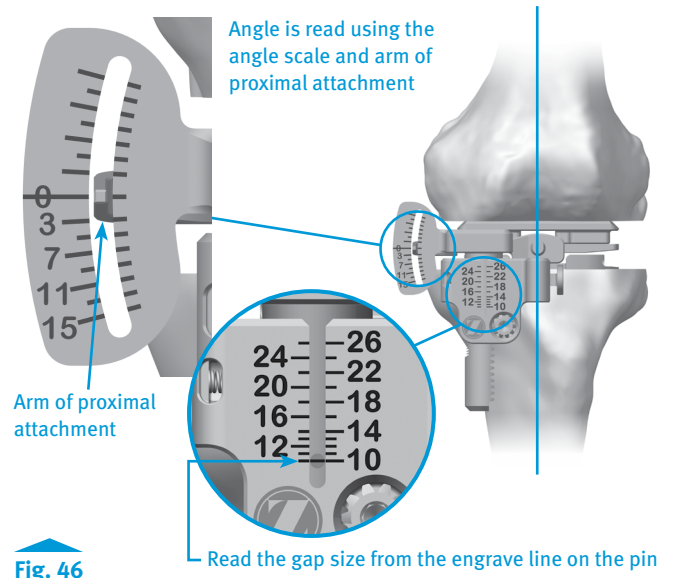

Fig. 46

3. Flexion Gap and Setting Femoral Rotation

- Remove the *Zimmer FuZion* Tensor from the extension gap. Remove the +9mm *Zimmer FuZion* Femoral Paddle. Assemble the Gap Referencing Drill Guide to the *Zimmer FuZion* Tensor (**Fig. 47**).

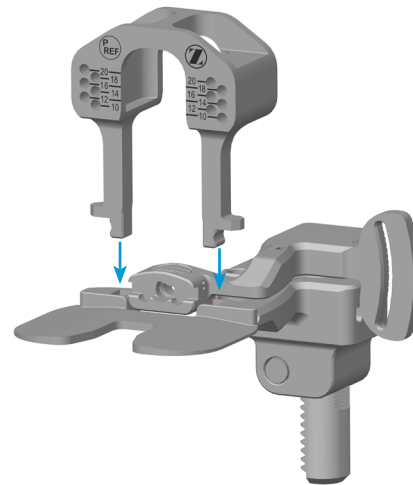

Fig. 47

Instruments



Zimmer FuZion
Tensor, Femoral
Assembly, Left
42-5097-021-00



Zimmer FuZion
Tensor, Tibial
Assembly, Left
42-5097-021-01



Zimmer FuZion
Gap Referencing
Drill Guide
42-5097-050-00



Zimmer FuZion
Femoral Paddle,
+0mm, Left
42-5097-031-00



3.5mm Hex Head
Screwdriver
00-5120-087-00



Zimmer FuZion
Femoral Paddle,
+9mm
42-5097-030-09

- Bring the leg into 90° of flexion. Insert the *Zimmer FuZion* Tensor between the cut tibial surface and the uncut posterior condyles, as shown (Fig. 48).
- Using the 3.5mm Hex Head Screwdriver, apply the appropriate amount of force to distract the joint (Fig. 48).

Note: The medial collateral ligament will engage first. The femur will then rotate internally, tightening the lateral collateral until equal tension of both is achieved.

Caution: If a posterior rough cut is made do not use the angle and gap scales on the *Zimmer FuZion* Tensor.

- Ensure that the scale reads between 3-7° of rotation using Whiteside's line and/or the epicondylar axis as an additional visual reference to confirm component rotation (Fig. 48). If the collateral soft-tissue does not provide adequate stability, the surgeon should use his/her professional medical judgment to assess whether a more constraining implant/system or revision implant/system is necessary.
- Double check the posterior cut creates a flexion gap within 2mm of the extension gap (Fig. 48).

Caution: Double check, when measuring in flexion, that the distance on the tensor scale is within 2mm of what was measured in extension. Remember to use the +0mm *Zimmer FuZion* Femoral Paddle to evaluate the joint space prior to resection and +9mm *Zimmer FuZion* Femoral Paddle to evaluate the joint space after resection (Fig. 48).

- Select the holes on the drill guide that match the gap measured in extension. **Ensure the *Zimmer FuZion* Gap Referencing Drill Guide is parallel, or flush, with the face of the distal femur.** Drill the holes using the 3.2mm Drill. These will position the *Persona* Posterior Referencing 4-in-1 Cut Guide (Fig. 49).

Note: The orientation of the drill guide can be rotated 180° to change the offset of the distal femoral contacting surface by 10mm.

Note: The gap referencing drill guide can only be used with the *Persona* Posterior Referencing 4-in-1 Cut Guides.

Note: The Gap Referencing Drill Guide is designed to ensure a rectangular flexion space without consideration of the posteriorcondylar position.

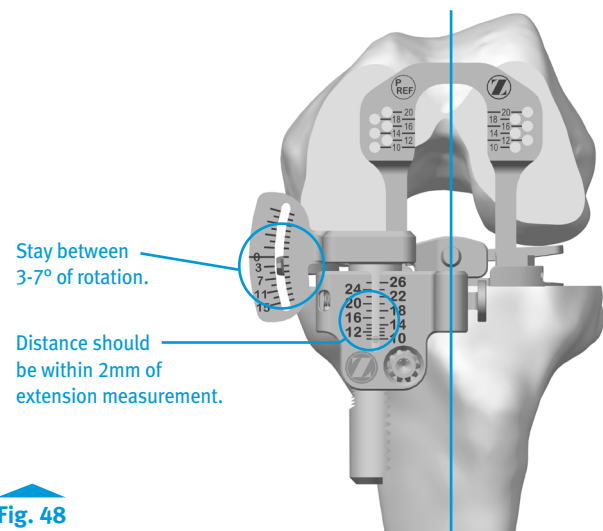

Fig. 48

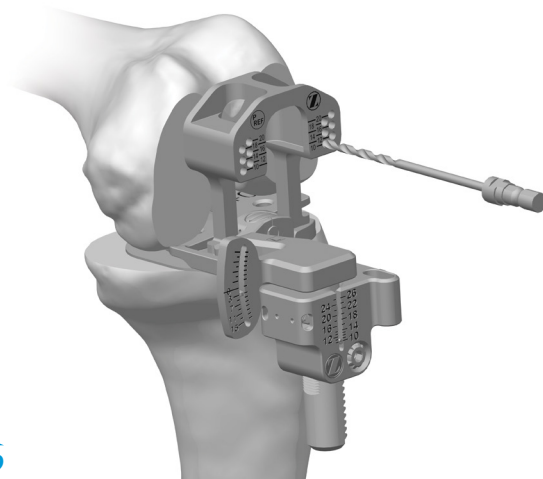

Fig. 49

Instruments



Zimmer FuZion
Tensor, Femoral
Assembly, Left
42-5097-021-00



Zimmer FuZion
Tensor, Tibial
Assembly, Left
42-5097-021-01



Zimmer FuZion
Gap Referencing
Drill Guide
42-5097-050-00



Zimmer FuZion
Femoral Paddle,
+0mm, Left
42-5097-031-00



3.5mm Hex Head
Screwdriver
00-5120-087-00



Zimmer FuZion
Femoral Paddle,
+9mm
42-5097-030-09



3.2mm Drill
00-5120-085-00

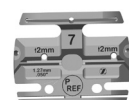

Persona Posterior
Referencing 4-in-1
Cut Guide - Size 7
42-5099-044-62

4. Size Femur

- Assemble the Posterior Referencing Sizer Boom with the Posterior Referencing Sizer (Fig. 50).

Note: The *Persona* Posterior Referencing Sizer is only intended to provide an estimated component size at this point in the surgical technique. Do not use the sizer to drill holes for the 4-in-1 Cut Guide.

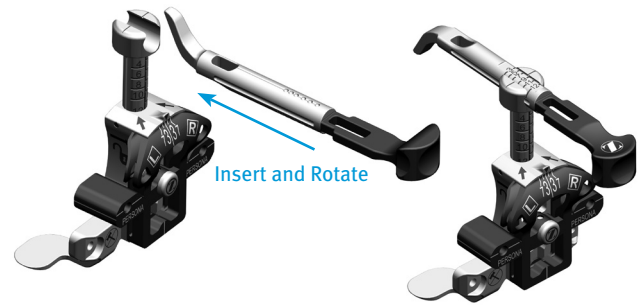

Fig. 50

- Refer to *Persona* The Personalized Knee System Posterior Referencing Surgical Technique (97-5026-081-00) for instructions and feature highlights of the Posterior Referencing Sizer and 4-in-1 Cut Guides.
- Use the *Persona* Posterior Referencing Sizer to size the femur (Fig. 51).
- Insert the *Persona* Posterior Referencing 4-in-1 Cut Guide (Fig. 51).

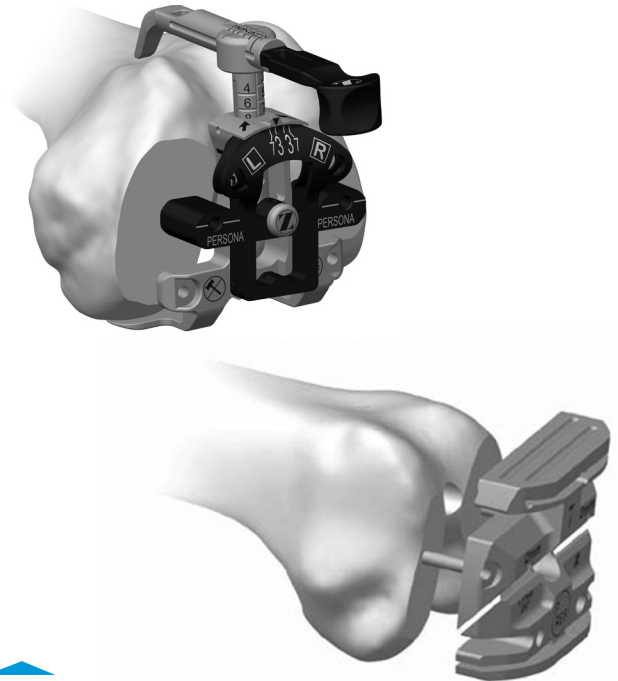

Fig. 51

Instruments



Persona Posterior Referencing Sizer
42-5099-040-00



Persona Posterior Referencing Sizer Boom
42-5099-040-10



Persona Posterior Referencing 4-in-1 Cut Guide - Size 7
42-5099-044-62

5. Verify Rotation of Persona 4-in-1 Cut Guide and Ensure No Notching

- Prior to resection of the posterior condyles, attach the *Zimmer FuZion* 4-in-1 Cut Guide Adapter to the *Zimmer FuZion* Tensor and insert into the posterior holes of the *Persona* Posterior Referencing 4-in-1 Cut Guide (Fig. 52).
- Using the 3.5mm Hex Head Screwdriver apply the appropriate amount of force to distract the joint
- Check to ensure the posterior surface of the *Persona* Posterior Referencing 4-in-1 Cut Guide is parallel to the tibia and the angle read out is 0° and flexion gap is appropriate based on what was measured in extension.

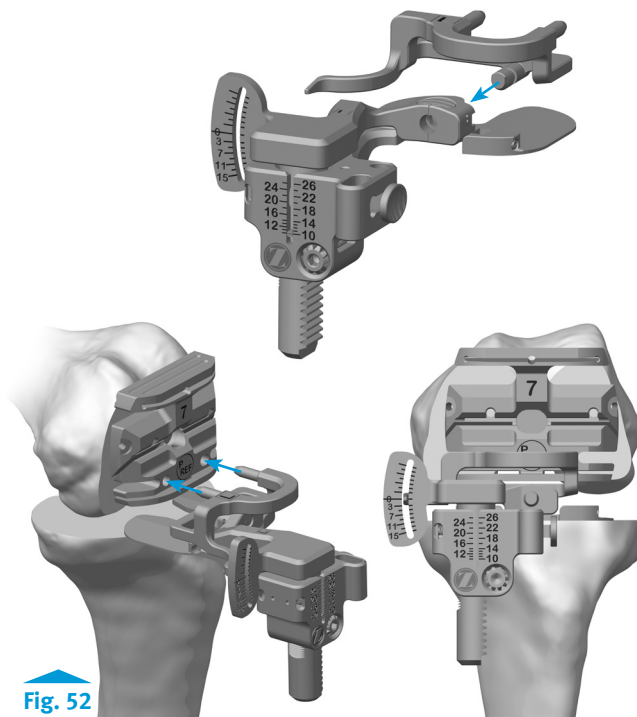
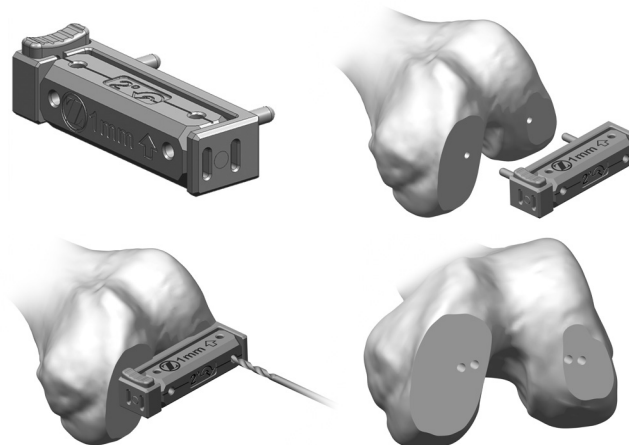

Fig. 52

- If needed, use the *Persona* Shift Block to adjust the *Persona* Posterior Referencing 4-in-1 Cut Guide rotation (2°) or AP position (1mm) prior to making any cuts with the *Persona* Posterior Referencing 4-in-1 Cut Guide. Place the pegs of the *Persona* Shift Block in the holes created by the *Zimmer FuZion* Sizer for the *Persona* Posterior Referencing 4-in-1 Cut Guide. Establish the new block position by drilling through the holes on the face of the *Persona* Shift Block that specifies the adjustment that is intended. Use a 3.2mm Drill to drill the holes. Remove the shift block, Place the *Persona* Posterior Referencing 4-in-1 Cut Guide back on the bone (Fig. 53.). Use the *Zimmer FuZion* 4-in-1 Cut Guide Adapter to verify the *Persona* Posterior Referencing 4-in-1 Cut Guide's new position is correct.



Persona Shift Block

Fig. 53

Caution: Be sure to put the *Persona* Posterior Referencing 4-in-1 Cut Guide in the new holes created by the *Persona* Shift Block.

Instruments

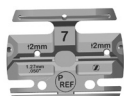
3.2mm Drill
00-5120-085-00Persona
Shift Block
42-5099-085-10Persona Posterior
Referencing 4-in-1
Cut Guide - Size 7
42-5099-044-62Resection Guide
00-5977-084-00Zimmer FuZion
Tensor, Femoral
Assembly, Left
42-5097-021-00Zimmer FuZion
Tensor, Tibial
Assembly, Left
42-5097-021-01Zimmer FuZion
4-in-1 Cut Guide
Adapter, Left
42-5097-041-003.5mm Hex Head
Screwdriver
00-5120-087-00

- Check for notching by placing a resection guide in the anterior cut slot or by using a 3.2mm Drill in the drill hole in the anterior cut slot of the *Persona* Posterior Referencing 4-in-1 Cut Guide before making cuts. Change size as appropriate to avoid notching (Fig. 54).

Caution: By matching the extension gap the posterior condylar resection may be significantly greater or less than the standard 9mm posterior resection.



Fig. 54

6. Check the Flexion Space

- The +9mm *Zimmer FuZion* Femoral Paddle can be attached to the *Zimmer FuZion* +0mm Femoral Paddle and used with the *Zimmer FuZion* Tensor to check the flexion gap after resection (Fig. 55).

7. Complete Procedure

- Use *Persona* Primary Instruments to complete the procedure.

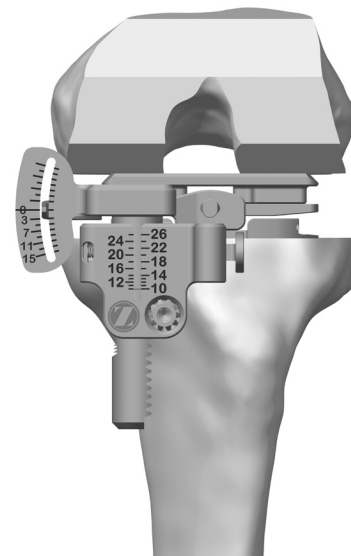

Fig. 55

Instruments



3.5mm Hex Head
Screwdriver
00-5120-087-00



Zimmer FuZion
Femoral Paddle,
+0mm, Left
42-5097-031-00



Zimmer FuZion
Tensor, Femoral
Assembly, Left
42-5097-021-00



Zimmer FuZion
Tensor, Tibial
Assembly, Left
42-5097-021-01



Zimmer FuZion
Femoral Paddle,
+9mm
42-5097-030-09



3.2mm Drill
00-5120-085-00



Resection Guide
00-5977-084-00

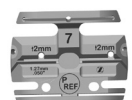

Persona Posterior
Referencing 4-in-1
Cut Guide - Size 7
42-5099-044-62

Transitioning from CR to PS

- The transition from Cruciate Retaining (CR) component to a Posterior Stabilized (PS) component is a fundamental shift in philosophy. Both systems utilize component geometry and positioning to optimize kinematics and survivorship. Both systems have unique approaches to implantation and both systems are successfully used.
- Zimmer's *Persona* Personalized Knee System CR component carries its attributes from Zimmer's *Natural-Knee*® System. The geometry of the femoral component utilizes a "big wheel/ little wheel" design that provides rollback replicating the natural kinematics of the knee. In addition, the tibial polyethylene is more conforming medially and less conforming laterally. The slope of the poly is recommended to be 7° to align to the slope of the natural anatomy. The geometry and cuts are intended to put the components in a position to work with the natural anatomy given the preservation of the cruciate ligament, to provide a natural feel and motion.
- A transition from CR to a posterior cruciate substituting constraint within this system is typically an Ultra-Congruent (UC) polyethylene tibial insert design that drives motion with a deep concave dish in the medial compartment. The tibial insert also has pronounced anterior and posterior lips to provide anterior/posterior constraint and prevent posterior roll off. The transition to the UC is seamless. The CR femoral component is used with the UC. Removal of the PCL is the only requirement when using the UC component. The UC tibial polyethylene is attached to the tibial baseplate implant in the same manner as the CR tibial polyethylene.
- Zimmer's *Persona* Personalized Knee System PS component carries its attributes from Zimmer's *NexGen*® Knee System. The geometry of the femoral component is symmetric, with a posterior condyle that's 1mm thicker than the distal condyle. The post that is used as a substitute for the posterior cruciate engages the cam of the femoral component in mid-flexion and forces femoral rollback. The recommended tibial slope for this component 3°. The geometry and cuts are intended to drive motion.
- In the situations when starting with a CR approach and determining in-situ that a higher level of constraint is needed, certain considerations should be used to ensure that a stable knee with full extension is enabled.
- The 1mm thicker posterior condyle of the PS femoral component and the box that houses the PS post tibial polyethylene will require some additional preparation when making the transition.
- Considerations transitioning from CR to a PS design:
 1. Utilize a UC tibial insert
 2. Recut the tibial slope (from 7 to 3°)
 3. Remove the posterior cruciate ligament

Balancing Matrix

Check Extension Gap

- After the proximal tibia and distal femur have been resected, the extension gap can be evaluated using the *Zimmer FuZion* Spacer Block or the *Zimmer FuZion* Tensor. Position the knee in full extension. The distal thickness of the *Persona* femoral component is 9mm and the minimum *Persona* tibial articular surface/baseplate construct is 10mm. If the *Zimmer FuZion* Spacer Block with the +9mm Paddle (19mm) does not fit into the resected joint space in extension, it will be necessary to remove additional bone from the femur.
- Use the *Zimmer FuZion* Spacer Block or the *Zimmer FuZion* Tensor to check the extension gap. Insert the *Zimmer FuZion* Spacer Block or Tensor between the resected surfaces of the femur and tibia. If necessary, add *Zimmer FuZion* Shims to the *Zimmer FuZion* Spacer Block or adjust the *Zimmer FuZion* Tensor until the desired soft tissue tension is obtained. Use the alignment rod to check overall alignment. Varus and valgus stress can be used to evaluate ligament stability. Ligament releases can be performed, at this point, to create an extension gap that is rectangular. When the extension gap is balanced, proceed to size femur, establish external rotation and finish the femoral cuts.

Check Flexion Gap

- After the femoral finishing cuts have been completed and with the knee in 90° flexion, use the *Zimmer FuZion* Spacer Block or the *Zimmer FuZion* Tensor to check ligament balance and joint alignment in flexion. Check ligament balance. If necessary, insert progressively thicker *Zimmer FuZion* Spacer Block Shims underneath *Zimmer FuZion* Spacer Block or adjust the *Zimmer FuZion* Tensor until the desired soft tissue tension is obtained.

Correcting Gaps (Fig. 56):

1. If a knee is too tight in both flexion and extension, reducing the height of the tibial articular surface may be sufficient to balance the construct. If the thinnest tibial articular surface is too tight, resect more tibia.
2. If the knee is tight in flexion but acceptable in extension, two options exist. One option is to release the PCL. If the PCL is absent, change constraint to UC. The second option is to downsize the femoral component.
3. If the joint is loose in extension and tight in flexion one option is to use a smaller sized femoral component possibly with a thicker polyethylene component.
4. If the joint is acceptable in flexion but tight in extension, two options exist. One is to release the posterior capsule from the femur. Another alternative is to resect more distal femoral bone. This moves the femoral component proximally on the femur at the expense of elevating the joint line.

		Extension		
		Tight	OK	Loose
Flexion	Tight	<p>1</p> <ul style="list-style-type: none"> • Reduce articular surface thickness • Recut tibia 	<p>2</p> <ul style="list-style-type: none"> • Release PCL, Change to a UC • For Anterior Referencing: Down size femoral component • For Posterior Referencing: Down size femoral component and shift anterior 	<p>3</p> <ul style="list-style-type: none"> • Down size femoral component increase articular surface thickness • For Anterior Referencing: Down size femoral component; increase tibial articular surface thickness • For Posterior Referencing: Down size femoral component and shift anterior; increase tibial articular surface thickness
	OK	<p>4</p> <ul style="list-style-type: none"> • Release the posterior capsule from the femur • Resect more distal femur (will elevate the joint line) 	<p>5</p> <p>OK</p>	<p>6</p> <ul style="list-style-type: none"> • Down size femoral component, increase articular surface thickness • For Anterior Referencing: Down size femoral component; increase tibial articular surface thickness • For Posterior Referencing: Down size femoral component and shift anterior; increase tibial articular surface thickness
	Loose	<p>7</p> <ul style="list-style-type: none"> • For Anterior Referencing: Up size femoral component • For Posterior Referencing: Up size femoral component and shift posterior • Reduce articular surface thickness • Posterior release, increase articular surface thickness 	<p>8</p> <ul style="list-style-type: none"> • For Anterior Referencing: Up size femoral component • For Posterior Referencing: Up size femoral component and shift posterior • Posterior release, increase articular surface thickness 	<p>9</p> <ul style="list-style-type: none"> • Increase articular surface thickness

Fig. 56

5. If both components are acceptable, no further modification is necessary.
6. If the joint is acceptable in flexion and loose in extension, consider downsizing the femoral component with a thicker tibial articular surface.
7. If the joint is loose in flexion and tight in extension, a larger femoral component may suffice combined with a posterior release.
8. If the joint is loose in flexion and acceptable in extension, increasing the femoral size may equalize the gaps. Alternatively, moving the femoral component proximally and applying a thicker tibial articular surface will equalize the gaps. Another option is to fill the flexion gap with the appropriate poly and perform a posterior release to increase the extension gap.
9. If a joint is symmetrically loose in both flexion and extension, a thicker tibial articular surface will usually solve both problems.

TECHNIQUE TIP

8.A

Also consider the position of the patella and/or the joint line when deciding which correction to make.

Note: after applying one of these solutions, perform another trial reduction. This will identify any new problem or a variation of the initial problem that may exist.

		Extension		
		Tight	OK	Loose
Flexion	Tight	1 <ul style="list-style-type: none"> Reduce articular surface thickness Recut tibia 	2 <ul style="list-style-type: none"> Release PCL, Change to a UC For Anterior Referencing: Down size femoral component For Posterior Referencing: Down size femoral component and shift anterior 	3 <ul style="list-style-type: none"> Down size femoral component increase articular surface thickness For Anterior Referencing: Down size femoral component; increase tibial articular surface thickness For Posterior Referencing: Down size femoral component and shift anterior; increase tibial articular surface thickness
	OK	4 <ul style="list-style-type: none"> Release the posterior capsule from the femur Resect more distal femur (will elevate the joint line) 	5 <p>OK</p>	6 <ul style="list-style-type: none"> Down size femoral component, increase articular surface thickness For Anterior Referencing: Down size femoral component; increase tibial articular surface thickness For Posterior Referencing: Down size femoral component and shift anterior; increase tibial articular surface thickness
	Loose	7 <ul style="list-style-type: none"> For Anterior Referencing: Up size femoral component For Posterior Referencing: Up size femoral component and shift posterior Reduce articular surface thickness Posterior release, increase articular surface thickness 	8 <ul style="list-style-type: none"> For Anterior Referencing: Up size femoral component For Posterior Referencing: Up size femoral component and shift posterior Posterior release, increase articular surface thickness 	9 <ul style="list-style-type: none"> Increase articular surface thickness

Fig. 56

Persona Knee Surgical Technique Library

Surgical Technique Name	Literature Number
<i>Persona</i> The Personalized Knee System Surgical Technique	97-5026-001-00
<i>Persona</i> The Personalized Knee System Posterior Referencing Surgical Technique	97-5026-081-00
<i>Persona</i> The Personalized Knee System <i>Trabecular Metal™</i> Tibia Surgical Technique	97-5026-027-00
<i>Persona</i> The Personalized Knee System <i>Trabecular Metal</i> Femur Surgical Technique	97-5026-070-00

Disclaimer

This documentation is intended exclusively for physicians and is not intended for laypersons. Information on the products and procedures contained in this document is of a general nature and does not represent and does not constitute medical advice or recommendations. Because this information does not purport to constitute any diagnostic or therapeutic statement with regard to any individual medical case, each patient must be examined and advised individually, and this document does not replace the need for such examination and/or advice in whole or in part. Please refer to the package inserts for important product information, including, but not limited to, contraindications, warnings, precautions, and adverse effects.

Contact your Zimmer representative or visit us at www.zimmer.com

