

# Persona IQ<sup>®</sup>

THE SMART KNEE<sup>™</sup>

CANARY canturio<sup>™</sup> Tibial Extension with  
CHIRP<sup>™</sup> System  
Surgical Technique

**R<sub>x</sub>**only

CAUTION: Federal law (USA) restricts this device to sale by or on the order of a physician.

## Table of Contents

1. Introduction	3
2. Terms and Acronyms	6
3. Preoperative Planning	7
4. Surgical Approach	8
5. Patient Preparation	9
6. Magnet Usage	10
7. Symbols	11
8. Compatible Screw/Pin Information	12
9. Pre-Operative: Setting Up the or Base Station and Testing the canturio™ Tibial Extension (CTE)	14
10. Sizing and Drilling the Tibia	21
11. Sizing and Drilling of the Tibia (Alternative Technique)	28
12. Broaching the Tibia	31
13. Provisional Assembly and Trialing	34
14. Activating the CTE Implant	38
15. Assembling the CTE Implant with the Persona Tibial Plate	40
16. Implanting the CTE and Persona Assembly	45
17. Linking the CTE and Persona IQ® Implant Components to the Patient	48

# 1. Introduction

Successful total knee arthroplasty (TKA) depends in part on re-establishment of normal lower extremity alignment, proper implant design and orientation, secure implant fixation, and adequate soft tissue balancing and stability. The Zimmer Biomet Persona IQ® The Personalized Knee® is designed to help the surgeon accomplish these goals by combining alignment accuracy with a simple, straight-forward technique.

The instruments and technique assist the surgeon in restoring the center of the hip, knee, and ankle to lie in a straight line, establishing a neutral mechanical axis. The femoral and tibial components are oriented perpendicular to this axis. Femoral rotation is determined using the posterior condyles, the epicondylar axis, or Whiteside's line as a reference. The instruments enable accurate cuts to ensure robust component fixation.

A wide variety of component sizes, shapes, and constraint options allow for optimized component fit and soft tissue balancing. The femur, tibia, and patella are prepared independently and can be cut in any sequence using the principle of measured resection (removing enough bone to allow replacement by the prosthesis). Adjustment cuts may be needed later. The anterior referencing technique uses the anterior cortex to set the anteroposterior (A/P) position of the femoral component. The posterior condyle cut is variable.

Additional technique steps are found in the *Zimmer Biomet Persona Knee Surgical Technique (97-5026-001-00)* and the *Zimmer Biomet Persona CPS Surgical Technique (97-5026-072-00)*.

## **1.1 Canturio™ Tibial Extension (CTE) with CHIRP™ System**

The canturio™te (CTE) with Canary Health Implanted Reporting Processor (CHIRP™) is a tibial extension containing electronics and software. It can only be used with the Zimmer Biomet Persona IQ® The Personalized Knee®. Using internal motion sensors, the CTE implant collects kinematic data pertaining to a patient's gait and activity level following TKA. The kinematic data produced by the CTE implant is intended as an adjunct to other physiological parameter measurement tools used post-TKA procedure as directed by the physician. The CTE implant also provides stability to the knee implant in the same manner as a traditional tibial extension.

The Canary Medical Canturio Tibial Extension (CTE) with Canary Health Implanted Reporting Processor (CHIRP) System is intended to provide objective kinematic data from the implanted medical device during a patient's total knee arthroplasty (TKA) post-surgical care. The kinematic data are an adjunct to other physiological parameter measurement tools applied or utilized by the physician during the course of patient monitoring and treatment post-surgery.

The device is indicated for use in patients undergoing a cemented TKA procedure that are normally indicated for at least a 58mm sized tibial stem extension.

The objective kinematic data generated by the CTE with CHIRP System are not intended to support clinical decision-making and have not been shown to provide any clinical benefit.

The CTE with CHIRP System is compatible with Zimmer Persona® Personalized Knee System.

**WARNING - The kinematic data from this device have not been demonstrated to have clinical benefit. It is not intended to be utilized for clinical decision-making, and no data have been evaluated by FDA regarding clinical benefits.**

The CTE with CHIRP System consists of the CTE implant, plus the following external components:

- Canary surgical instrumentation
- Canary PC with Operating Room Application (OR App)
- Canary OR Base Station

The external components are used throughout the surgical procedure to activate the CTE implant, prepare the patient anatomy, assemble the CTE implant to the Zimmer Biomet Persona IQ® tibial plate to form the patient’s knee prosthesis, and link the implanted CTE implant and Persona IQ components with the specific TKA patient.

Figure 1 shows the CTE implant on the left and a representation of the CTE implant assembled with the Zimmer Biomet Persona IQ tibial plate on the right.



*Figure 1*

This Surgical Technique document is to be used only when utilizing the CTE with primary Persona IQ knee implants and is not for use with Persona® Revision, or with other Zimmer Biomet knee systems, such as NexGen® Knee, Vanguard®, or Natural-Knee® II systems.

The surgical technique for implanting the Persona® IQ Knee with the CTE uses a combination of Persona® and Canary Medical™ instrumentation. Pay close attention to the instructions in this Surgical Technique document to ensure you are using the correct instrumentation for each step of the procedure.

See the *Zimmer Biomet Persona Knee Surgical Technique* (97-5026-001-00) for the available implant constraint options.

## 2. Terms and Acronyms

**Table 1** lists Terms and Acronyms used in this document.

*Table 1: Terms and Acronyms*

Term or Acronym	Meaning
A/P	Anteroposterior
CHIRP	Canary Health Implanted Reporting Processor
Cloud	Canary Medical Cloud Based Data Management Platform
CN	Circulating Nurse
CTE	canturio™ tibial extension (te)
CPS	Constrained Posterior Stabilized
HCP	Health Care Professional
IM	Intramedullary
OR	Operating Room
PC	Personal Computer
PCL	Posterior Cruciate Ligament
RF	Radio Frequency
ROM	Range of Motion
TASP	Tibial Articular Surface Provisional
TKA	Total Knee Arthroplasty
USB Cable	Data cable used to make connections between the OR Laptop and OR Base Station and the OR Laptop and Barcode Scanner

### 3. Preoperative Planning

Use the information in this section during preoperative planning for the patient's TKA.

1. Obtain 36 inch or 53 inch standing AP and lateral radiographs of the extremity, as well as a sunrise view of the patella.
2. Visualize the entire femur to rule out any structural abnormalities, as the distal femoral cut will be referenced from an intramedullary rod in the medullary canal.
3. Review the patient radiographs.
4. Use the CTE 14mm x 58mm X-Ray Template (available through your Zimmer Biomet representative) on the patient's long-standing film to determine if the patient's anatomy is appropriate for a CTE Implant.

**WARNING:** The patient needs to have sufficient intramedullary space to accommodate the increased length of the CTE Implant in order to avoid cortical perforation. Before choosing the CTE Implant for a patient, assess if the patient's anatomy is appropriate for using the CTE 14mm x 58mm X-Ray Template.

The device is indicated for use in patients undergoing a cemented TKA procedure that are normally indicated for at least a 58mm sized tibial stem extension.

5. Determine the angle between the anatomic axis and the mechanical axis. This angle will be reproduced intraoperatively. This surgical technique helps the surgeon ensure that the distal femur will be cut perpendicular to the mechanical axis and, after soft tissue balancing, will be parallel to the resected surface of the proximal tibia.

## 4. Surgical Approach

The surgeon can choose a midvastus approach, a subvastus approach, or a parapatellar medial arthrotomy. Also, depending on surgeon preference, the patella can be either everted or sublaxed. The femur, tibia, and patella are prepared independently, and can be cut in any sequence using the principle of measured resection or gap balancing.



## 5. Patient Preparation

To prepare the limb for TKA, adequate muscle relaxation is required. The anesthesiologist should adjust the medication based on the patient's habitus and weight and administer to induce adequate muscle paralysis for a minimum of 30-40 minutes. It is imperative that the muscle relaxant be injected prior to inflation of the tourniquet. Alternatively, spinal or epidural anesthesia should produce adequate muscle relaxation. If desired, apply a proximal thigh tourniquet and inflate it with the knee in hyperflexion to maximize that portion of the quadriceps that is below the level of the tourniquet. Once the patient is draped and prepped on the operating table, determine the landmarks for the surgical incision.













## 6. Magnet Usage

**WARNING:** Some instruments in the Zimmer Biomet Persona IQ® system contain magnets. Active implantable medical devices may be adversely affected by magnets. Instruments containing magnets should be kept on an appropriate table or stand when not in use at the surgical site. All Zimmer Biomet Persona IQ magnetic instruments should be kept at a safe distance from both the CTE implant and the patient's existing active implantable medical device(s) (e.g., pacemaker).

## 7. Symbols

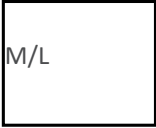
Table 2 shows the symbols that have been established for this Surgical Technique document.

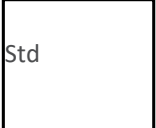
Table 2: Symbols for Surgical Technique

Term	Symbol	Term	Symbol	Term	Symbol
Left		Do Not Implant/Not for Implant		Cemented	
Right		Lock		Stemmed	
Varus/ Valgus		Unlock		Inset Only	
Medial/ Lateral		Anterior Referencing			
Standard		Do Not Impact			

## 8. Compatible Screw/Pin Information

**Table 3** contains information on various 3.2 mm screws/pins that are compatible with the Zimmer Biomet Persona IQ® system and canturio™te with CHIRP™ surgical instrumentation.



**WARNING:** If these screws/pins are used during the procedure for instrument fixation, they must be removed prior to closure as they are **NOT** implantable.

**CAUTION:** The 2.5 mm female hex screws and 2.5 mm male hex driver should not be used in cortical bone, as this may increase the incidence of stripping of the driver.

**Table 3: Screws and Pins Compatible with the Zimmer Biomet Persona® IQ System**

Screw/Pin	Screw/Pin Part #	Compatible Driver	Compatible Driver Part #	Shipped Sterile or Non-Sterile	# per Package	Single Use?
 25 mm x 2.5 mm Female Hex Screw	42-5099-025-25*	 2.5 mm Male Hex Driver	42-5099-025-00	Sterile	2	Yes
 75 mm x 3.2 mm Trocar Tipped Drill Pin (2.5 mm hex)	00-5901-020-00	 Pin/Screw Inserter	00-5901-021-00	Sterile	4	Yes
 Hex Headed Screw 33 mm long	00-5901-035-33			Sterile	2	Yes

\* The 2.5 mm female hex screws and 2.5 mm male hex driver should not be used in cortical bone, as this may increase the incidence of stripping of the driver.

Screw/Pin	Screw/Pin Part #	Compatible Driver	Compatible Driver Part #	Shipped Sterile or Non-Sterile	# per Package	Single Use?
 <p>MIS Quad-Spring Total Knee Headed Screw 48 mm long</p>	00-5983-040-48	 <p>Screw Inserter/Extractor</p>	00-5983-049-00	Sterile	1	Yes
 <p>25 mm Shorthead Holding Pin</p>	00-5977-056-03	 <p>Multi Pin Puller</p>	00-5901-022-00	Non-Sterile	1	No

## 9. Pre-Operative: Setting Up The OR Base Station and Testing the Canturio™ Tibial Extension (CTE)

**🔊 Technique Tip:** To streamline surgical flow, test the CTE implant prior to entering the OR.

**WARNING:** Retain the CTE implant in its packaging box. **DO NOT** remove the CTE implant from the packaging box until it has successfully passed Self-Test and Sensor Check and is ready to be introduced into the sterile field.

Use the steps below to set up the OR Base Station and test the CTE implant:

**NOTE:** The OR App **will not** function and you will not be able to log in without first connecting the OR Base Station to the Laptop.

1. Turn on the Canary Medical Laptop in an area with access to Wi-Fi.
2. Gather a CTE implant, the OR Base Station Unit, Bar Code Scanner, and USB cables.
  - a. Check the expiration date on the CTE implant package to ensure the implant is not expired.

**WARNING:** To avoid potential patient injury, do not use the CTE implant if it is expired.

**NOTE:** Do not open the CTE package at this time.

3. Set up the OR Base Station system in or near the OR but outside the sterile field, using the steps below:
  - a. Place the Base Station stand on a flat surface. Place the Base Station into the stand as shown in **Figure 2**. Insert the provided screw through the groove in the stand into the Base Station. Tighten the screw with a screwdriver.



**Figure 2: Base Station in Stand – Rear View**

- b. Connect the USB cable to the OR Base Station on one end and the Laptop PC on the other, as

shown in Figures 3 and 4.

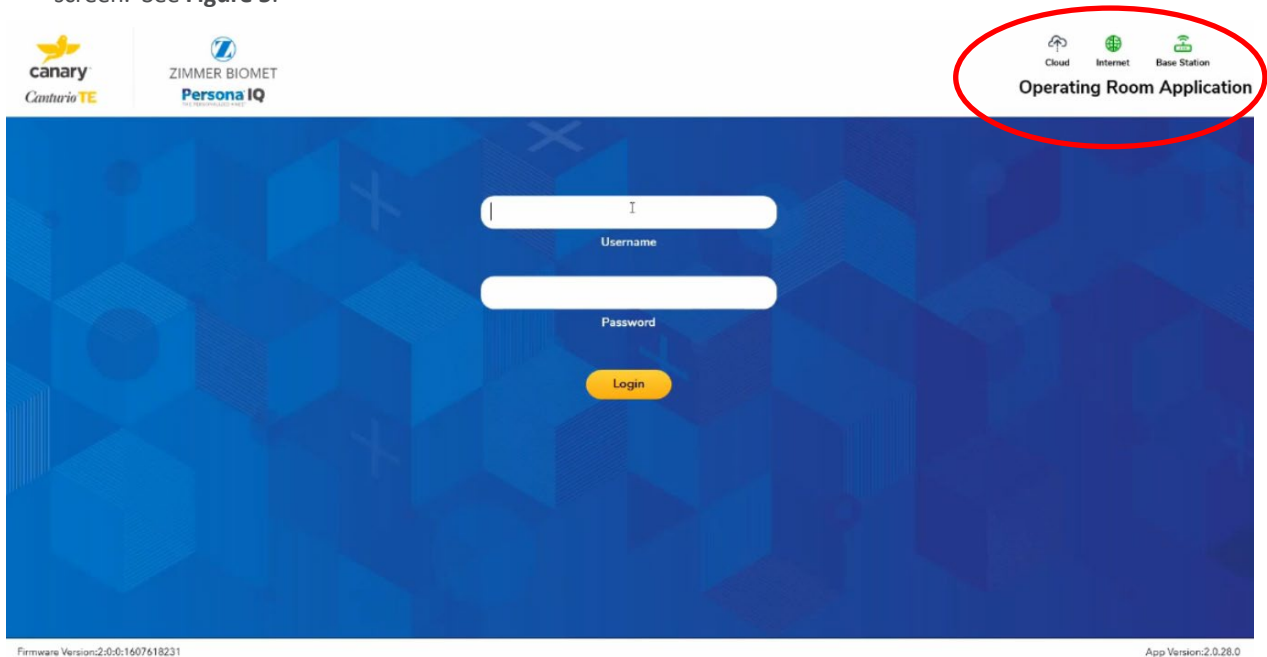

**Figure 3**



**Figure 4**

- c. Connect the Barcode Scanner to the Laptop.
4. On the Canary Medical laptop, the Canary Medical Operating Room Application (OR App) will start automatically, and you will see the image of an implant in the center of the screen.
5. Ensure the OR Base Station and Laptop are connected. This is indicated by the green “Base Station” icon at the top of the Laptop screen. See **Figure 5**.
6. Ensure an Internet connection has been established and the OR App is connected to the Canary Medical Cloud. This is indicated by the green Internet and Cloud icons at the top of the Laptop screen. See **Figure 5**.



**Figure 5**

7. Click on the image of the implant in the center of the screen. The login screen will appear. See **Figure 6**.

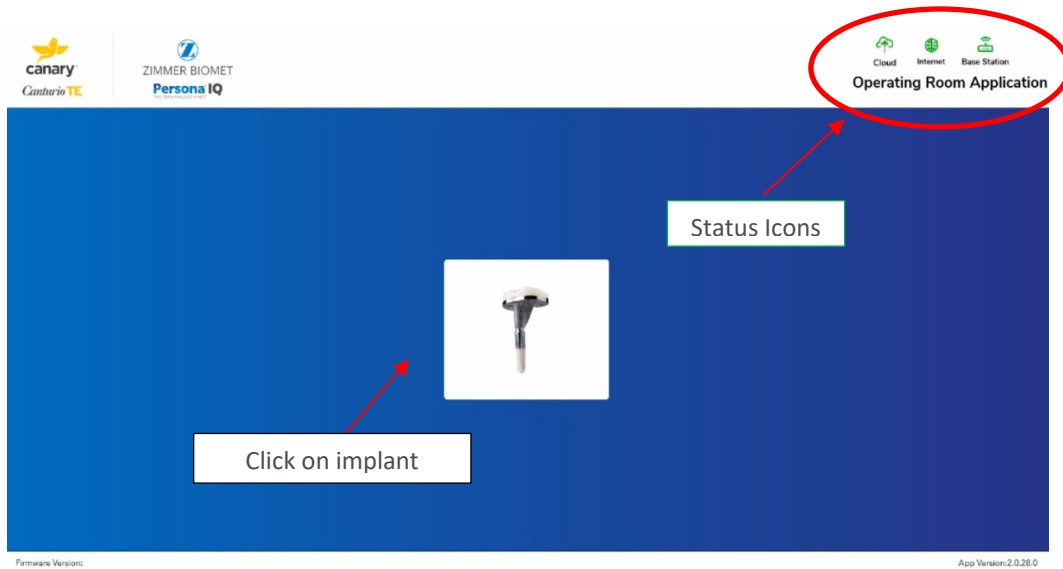

**Figure 6: Login Screen**

8. Enter your authorized Username and Password and click the “Login” button. This will take you to the Main Menu screen. **Figure 7.**

**NOTE:** A sync to the Cloud will automatically occur after the Internet connection is established and the user is logged in. A sync ensures the most recent patient data is loaded.

9. Place the CTE implant package’s large face on a flat surface within 6 feet of the OR Base Station that is connected to the Laptop.

**NOTE:** Placing the CTE implant (within package) more than 6 feet from the OR Base Station or having any large metal objects between or near the components can interfere with communication between the devices.

10. On the Main Menu screen, under “Preoperative,” click on the “Setup Implant” icon. Figure 7.





Figure 7: Main Menu

11. Click in the text box and enter or scan the CTE serial number from the implant package. Click “OK.”

Figure 8.

**NOTE:** If scanning, place the barcode scanner over the 2D bar code, as shown in the example image below.



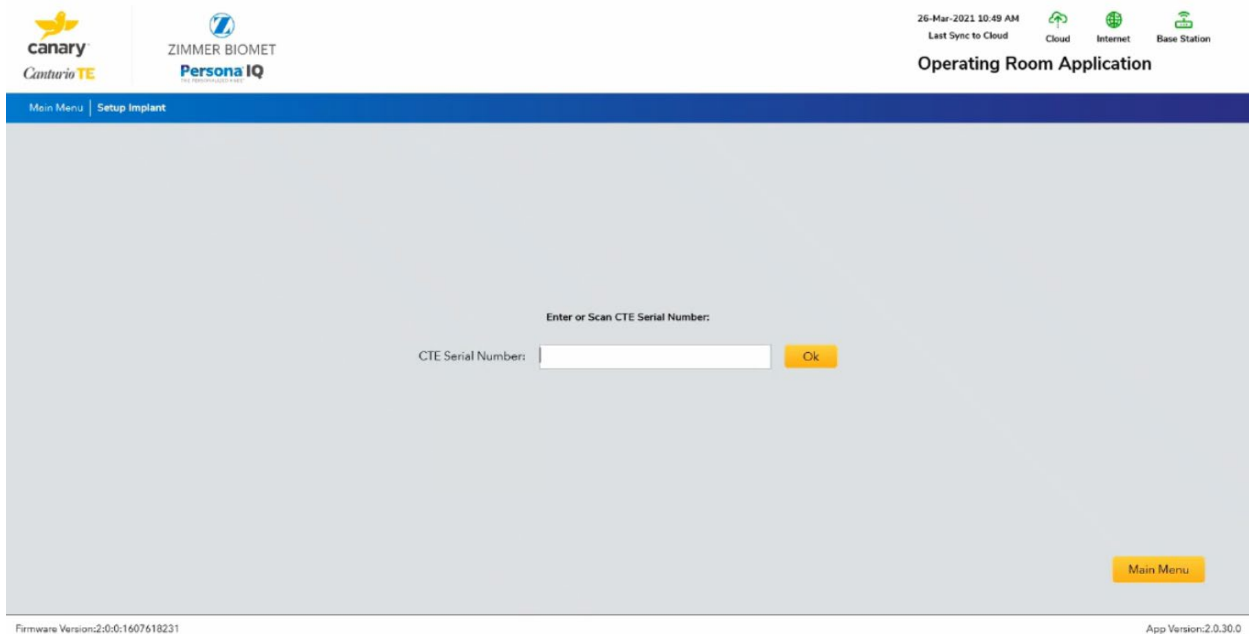

**Figure 8: Enter or Scan CTE Serial Number**

12. The CTE implant initiates communication with the OR Base Station. Click “OK” when this process is finished. **Figure 9.**

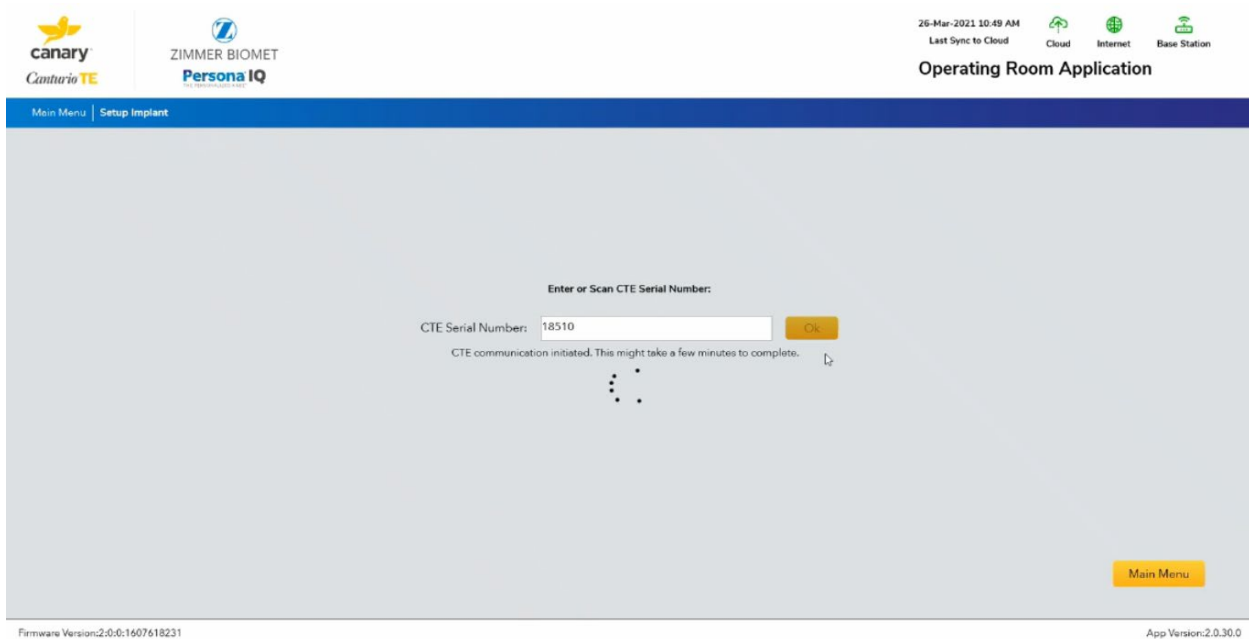
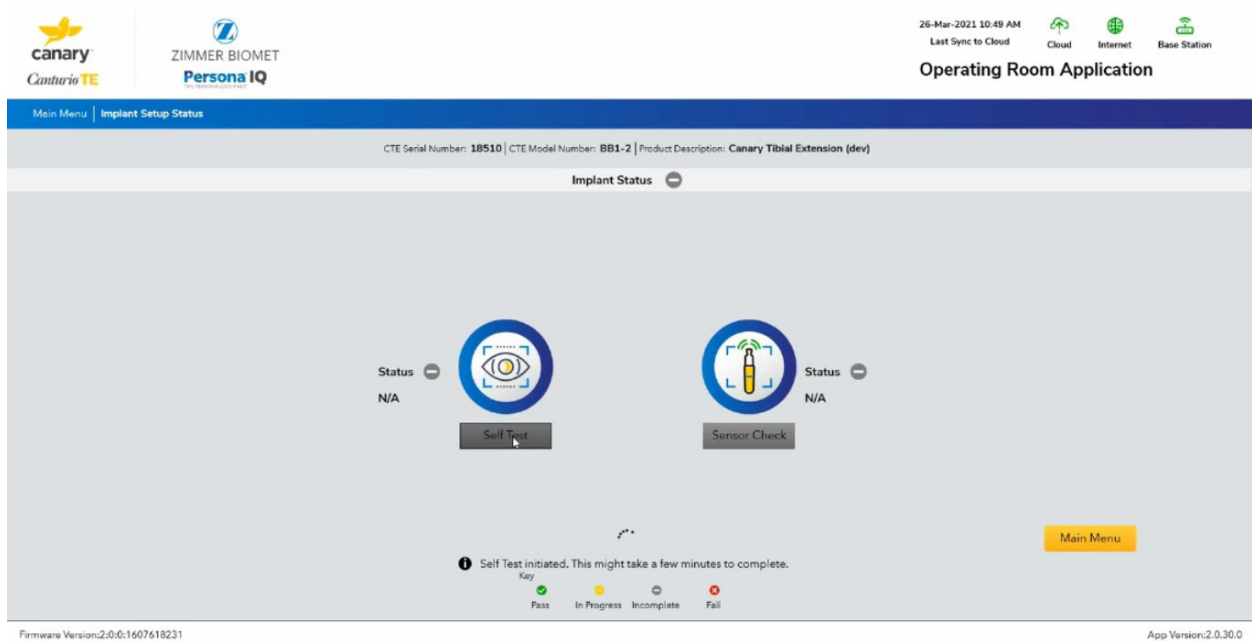

**Figure 9**

- a. Click on Self-Test. **Figure 10.** Upon initiation of a Self-Test the internal CTE electronics perform a series of self-tests and system communication integrity checks for all essential functions. If any of the self-tests fail, the microcontroller will log a permanent and specific error code in memory. These logs are then uploaded and evaluated. A “pass” result is only possible if all self-tests were successfully passed. If any of the self-tests failed or if any other non-passing log was generated

since the time of manufacturing, a “fail” result will be displayed.

**NOTE:** It is possible for a “Time Out” message to be displayed if a wireless connection could not be established between the Base Station and CTE implant due to proximity or interference. If the Self-Test takes more than 15 seconds to display a result, then lack of wireless communication may be the cause. Re-attempt Self-Test after ensuring the CTE implant and Base Station; a) are within 2 meters of each other, b) are not near large metal objects such as metal tables or metal shelves, and c) are not near Wi-Fi radiators such as mobile phones or computers. If the Self-Test continues to display a “Time Out” message, do NOT unpackage the device and contact Canary Medical at 1-833-722-6279 for Return Authorization.



**Figure 10: Self-Test**

- b. Click on Sensor Check. **Figure 11.** Upon initiation of a Sensor Check the IMU in the CTE captures a brief series of accelerometer and gyroscope (gyro) data which is then evaluated relative to the normal range for as-manufactured devices. A “pass” result is only possible if both accelerometer and gyro data are within the normal range.

**NOTE:** It is possible for a “fail” result to be displayed if the CTE was not stationary during the Sensor Check. Re-attempt Sensor Check after ensuring the CTE is stationary for 10 seconds after starting Sensor Check. If the Sensor Check continues to display a “fail” result, do NOT unpackage the device and contact Canary Medical at 1-833-722-6279 for Return Authorization.

**NOTE:** It is possible for a “Time Out” message to be displayed if a wireless connection could not be established between the Base Station and CTE implant due to proximity or interference. Re-attempt Sensor Check after ensuring the CTE implant and Base Station; a) are within 2 meters of each other, b) are not near large metal objects such as metal tables or metal shelves, and c) are not near WiFi radiators such as mobile phones or

computers. If the Sensor Check continues to display a “Time Out ” message, do NOT unpackage the device and contact Canary Medical at 1-833-722-6279 for Return Authorization.

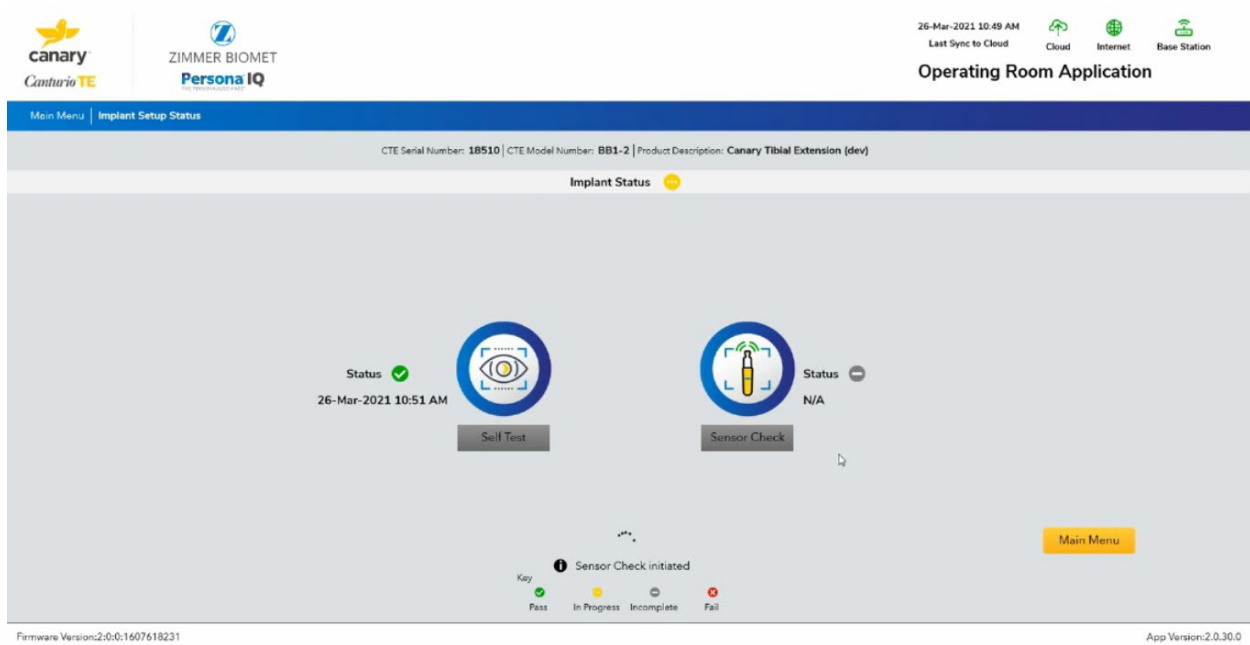

Figure 11: Sensor Check

13. When the Self-Test and Sensor Check are successful, the CTE implant is ready to be used for the patient’s TKA surgery. (Figure 12)

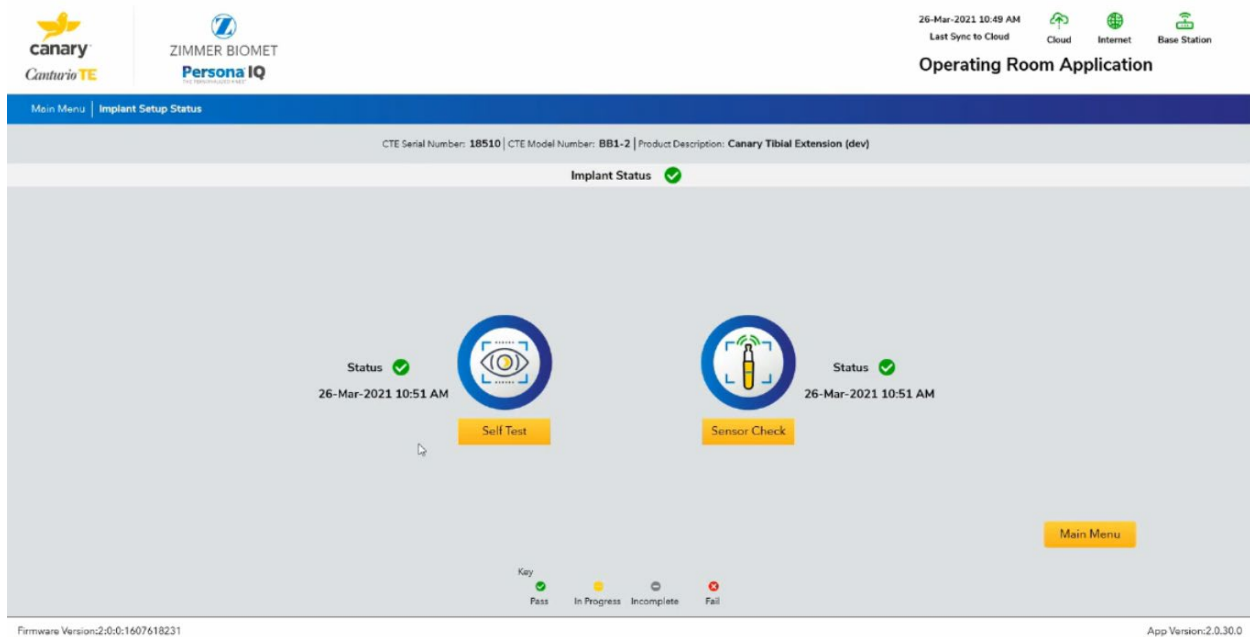



Figure 12: Self-Test and Sensor Check Successful

## 10. Sizing and Drilling the Tibia

### 10.1. Resect Proximal Tibia

Table 4 lists the instrumentation for use in this step.

Table 4: Canary Medical Tibia Cut Guides



Instrumentation	Image	Catalogue Number
Tibia Resection Cutting Guide, Left, 5 Degree		43-5399-051-05
Tibia Resection Cutting Guide, Right, 5 Degree		43-5399-052-05





Use the Tibia Cut Guide(s) listed in Table 4 or the preferred compatible instrumentation used for preparing the tibial cut as determined from pre-operative planning in Section 3 and follow the Zimmer Biomet *Persona Knee Surgical Technique* (97-5026-001-00) for tibial resection.

### 10.2. Establish Size and Rotation of Tibia

Table 5 lists the instrumentation for use in this step.

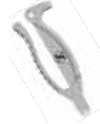
Table 5: Tibia Sizing Instrumentation

Instrumentation	Image	Catalogue Number
Persona Tibial Sizing Plate Handle		42-5399-017-00
Persona Cemented Tibial Sizing Plate Size A-F Right		42-5399-075-02

Instrumentation	Image	Catalogue Number
Multi Pin Puller		00-5901-022-00
Alignment Rod with Coupler		00-5785-080-00
2.5 mm Male Hex Driver		42-5099-025-00
25 mm x 2.5 mm Female Hex Screw		42-5099-025-25
25 mm Shorthead Holding Pin		00-5977-056-03

Use only Persona or Canary Medical tibial sizing, broaching, and provisional instrumentation for preparation of Persona implants.

1. Once tibial osteophytes have been thoroughly removed, select the appropriate right or left sizing plate that provides the desired tibial coverage, without overhang at any location. Appropriate tibial sizing is important as an over-sized tibial component can result in overhang, soft tissue impingement, and pain, or, with stemmed components, potential distal conflict between stem and bone.
2. Attach the tibial sizing plate handle to the cemented tibial sizing plate (**see Figure 13**). The recommended tibial rotational alignment is within 5 degrees of the axis created by the medial  $\frac{1}{3}$  of the tibial tubercle and the PCL attachment point. The engraved lines on the cemented tibial sizing plate can be used to aid in establishing the desired tibial rotation.
3. Rotate the cemented tibial sizing plate to attain the desired tibial rotational alignment. The notch in the lateral periphery of the sizing plate is used to establish proper position with respect to the lateral border of the tibia without medialization of the sizing plate.

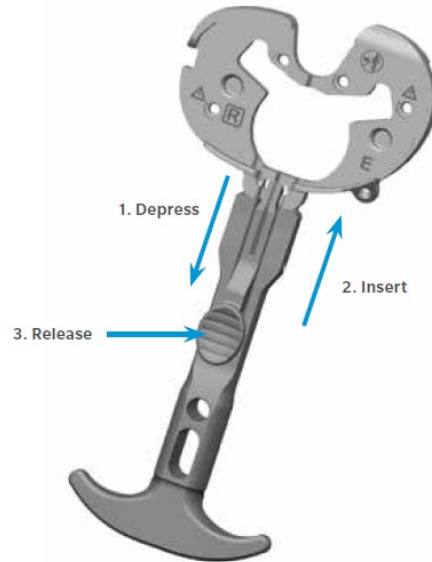

**Figure 13: Cemented Tibial Sizing Plate with Handle**

4. When the desired position has been obtained, secure the cemented tibial sizing plate by placing 25 mm x 2.5 mm (2.5 mm female hex) screws or 25 mm shorthead holding pin(s) in the medial and lateral holes near the PCL cutout of the cemented tibial sizing plate (**Figure 14**).

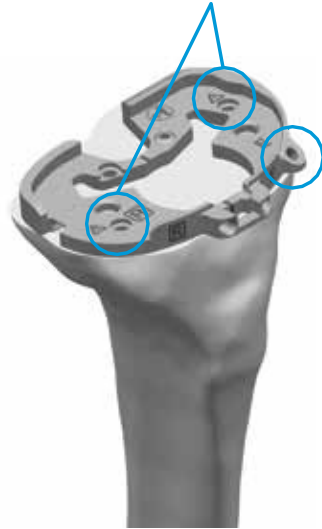

**Figure 14**

The remaining adjunct fixation holes shown on the surface of the cemented tibial sizing plate can be used if necessary. If the cemented tibial sizing plate is to be used as a provisional in later steps, male-headed screws/pins used in these holes must be removed prior to using the tibial articular surface provisionals (TASPs). See **Figure 15**.



Male-headed screws/pins must be removed from these holes for Tibial Articular Surface Provisionals (TASP)



**Figure 15**

5. Ensure that the cemented tibial sizing plate remains in the proper position when securing it to the bone. Once desired alignment has been verified with the alignment rod, remove the tibial sizing plate handle from the cemented tibial sizing plate.

☰ **Technique Tip:** **DO NOT** impact, lever, or pry the tibial sizing plate handle; this instrument is designed for alignment purposes only. Use the alignment rod in the hole or slot in the tibial sizing plate handle to verify proper tibial plate varus/valgus alignment. (See Appendix A in 97-5026-001-00 for correcting varus/valgus resections.)

☰ **Technique Tip:** If using a screw through the anterior medial hole on the periphery of the cemented tibial sizing plate, ensure that the cemented tibial sizing plate remains in the desired position and does not lift off posteriorly.

### 10.3. Drilling the Tibia

Table 6 lists the instrumentation for use in this step.





**CAUTION:** **DO NOT** use the Canary Medical Cemented Tibia Drill Bit 15.7mm Dia. x 58mm prior to creating a tibial pilot hole with the Persona Cemented Tibial Drill, 15.7 mm.

☰ **Technique Tip:** Insert the Persona Cemented Tibial Drill, 15.7 mm or Canary Medical Cemented Tibia Drill Bit 15.7mm Dia. x 58mm into the cemented tibial drill guide prior to starting the drill. By hand, hold the cemented tibial drill guide flush against the cemented tibial sizing plate while drilling.

☰ **Technique Tip:** When drilling, if you feel that excessive contact with the bone cortex is occurring, stop drilling and remove the drill, guide, and sizing plate. Use the provisional stem extension construct to check whether the fit in the bone is appropriate to allow use of the Canary Medical Tibial Extension. Downsize the tibial base plate if a shorter tibial keel is needed.

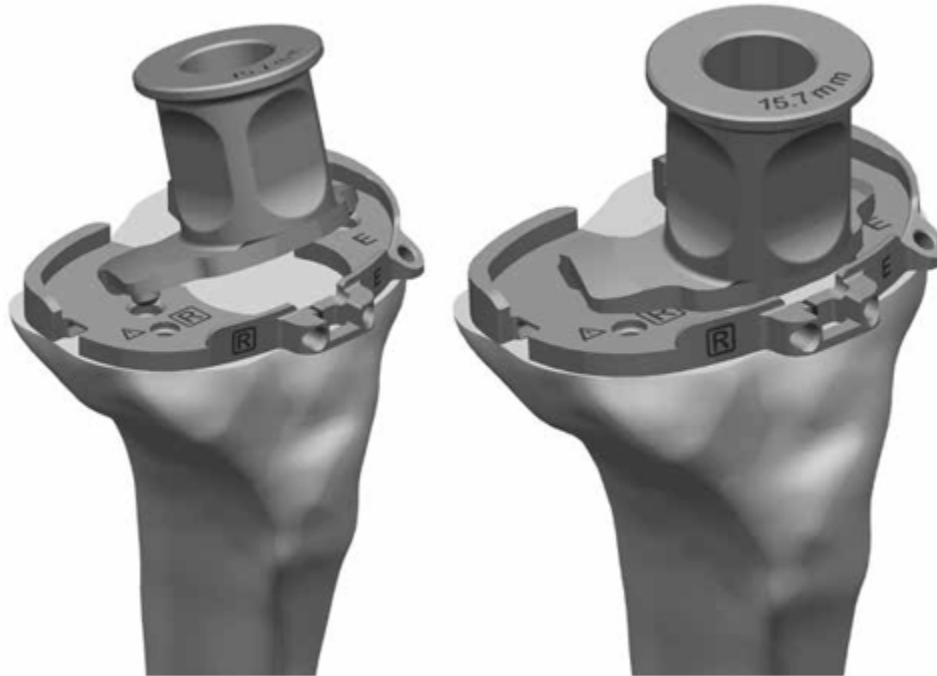

Table 6

Instrumentation	Image	Catalogue Number
Persona Cemented Tibial Drill, 15.7 mm		42-5399-018-10
Canary Medical Cemented Tibia Drill Bit 15.7mm Dia. x 58mm		43-5399-058-14
Persona Cemented Tibial Drill Guide - 15.7 mm		42-5399-020-00
Persona Cemented Tibial Sizing Plate Size F Right		42-5399-075-02
Canary Medical Straight Taper Stem Provisional 14 x 58mm		43-5571-058-14

The keel of the tibial implant has a unique location for every size; therefore, it is critical to select the proper size at this step, before drilling and broaching. Once these subsequent steps have been performed, the size should not be changed. If desired, femoral finishing can be performed in conjunction with provisional trialing at this stage to ensure that the desired range of motion and soft tissue balance can be attained with the cemented tibial sizing plate in place prior to drilling and broaching the tibia.

1. By hand, place and hold the cemented tibial drill guide on the tibia cemented tibial sizing plate, by first engaging the posterior tabs in the undercuts in the cemented tibial sizing plate and then making sure that the distal anterior portion of the cemented tibial drill guide is flush against the cemented tibial sizing plate. **Figure 16.**



*Figure 16*

**WARNING:** The procedure and drill used for the Persona with Canary Medical Tibial Extension (CTE) is different than the current Persona 14 mm x +30 mm, 15.7 mm Diameter Tibial Drill (42-5399-018-14) and 14 mm x +30 mm Tapered Stem Extension (42-5571-001-14). **DO NOT** use the Persona 14 mm x +30 mm, 15.7 mm Diameter Tibial Drill (42-5399-018-14) or the 14 mm x +30 mm Tapered Stem Extension (42-5571-001-14) to prepare the canal for the Canary Tibial Extension. The Persona 14 mm x +30 mm, 15.7 mm Diameter Tibial Drill (42-5399-018-14) will not drill deep enough for the Canary Tibial Extension and the associated cement mantle. Confirm that you are using the Canary Medical drill (43-5399-058-14) with the Canary Medical labeling before drilling.

**CAUTION: DO NOT** use the NexGen Drill Guide and/or NexGen Sizing Plates with the Canary Medical Cemented Tibial Drill Bit 15.7mm Dia. x 58mm.

2. Use the Persona Cemented Tibial Drill, 15.7 mm (42-5399-018-10) to create a pilot hole by drilling until the center of the size-specific engraved line on the cemented tibial drill is in line with the top of the cemented tibial drill guide (Figure 17). After drilling is complete, remove the Persona Cemented Tibial Drill, 15.7 mm, and attach the Canary Medical Cemented Tibia Drill Bit 15.7mm Dia. X 58mm.
3. Use the Canary Medical Cemented Tibia Drill Bit 15.7mm Dia. x 58mm to drill until the center of the size-specific engraved line on the cemented tibial drill is in line with the top of the cemented tibial drill guide (Figure 17). After drilling is complete, remove the cemented tibial drill guide.

**CAUTION: DO NOT** use the Canary Medical Cemented Tibia Drill Bit 15.7mm Dia. x 58mm (43-5399-058-14) prior to creating a tibial pilot hole with the Persona Cemented Tibial Drill, 15.7 mm (42-5399-018-10).

**☰ Technique Tip:** Insert the Persona Cemented Tibial Drill, 15.7 mm or Cemented Tibia Drill Bit 15.7mm Dia. x 58mm into the cemented tibial drill guide prior to starting the drill. Hold the cemented tibial drill guide flush against the cemented tibial sizing plate while drilling.

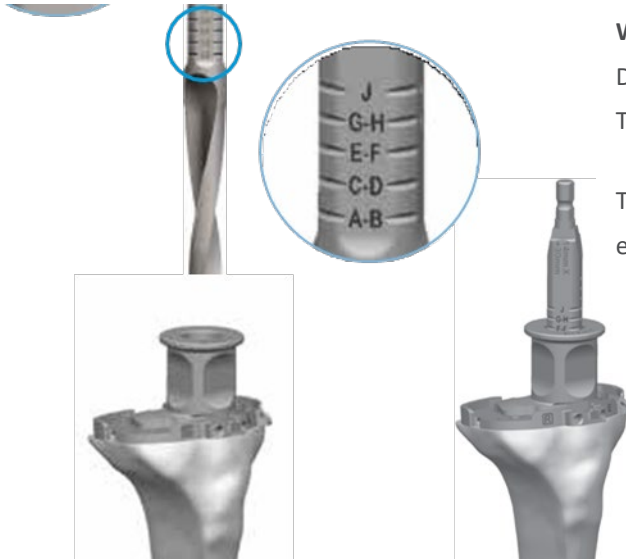

**WARNING: DO NOT** use the Persona 14 mm x +30 mm, 15.7 mm Diameter Tibial Drill (42-5399-018-14) for the Canary Medical Tibial Extension tibial preparation.







The Persona Tibial Drill (42-5399-018-14) will not drill deep enough for the stem extension and the associated cement

**Figure 17**

# 11. Sizing and Drilling of the Tibia (Alternative Technique)

Table 7 lists the instrumentation for use in this step.

Table 7

Instrumentation	Image	Catalogue Number
Persona Tibial Sizing Plate Handle		42-5399-017-00
Persona Cemented Tibial Sizing Plate Size F Right		42-5399-075-02
Persona Cemented Tibial Drill, 15.7 mm		42-5399-018-10
Canary Medical Cemented Tibial Drill Bit 15.7mm Dia. x 58mm		43-5399-058-14
Persona Cemented Tibial Drill Guide – 15.7 mm		42-5399-020-00
Persona Cemented Tibial Drill Stop Collar, 15.7 mm		42-5399-019-00

If desired, the cemented tibial drill stop collar may be used to aid in drilling to the correct depth.

1. Depress the button on the cemented tibial drill stop collar and slide the cemented tibial drill stop collar to the desired size-specific position on the Persona Cemented Tibial Drill, 15.7 mm or Canary Medical Cemented Tibia Drill Bit 15.7mm Dia. x 58mm (**Figure 18**).



Figure 18

2. Confirm that the correct size is displayed in the cemented tibial drill stop collar window (**Figure 19**) and that the cemented tibial drill stop collar is locked on the Persona Cemented Tibial Drill, 15.7 mm or Canary Medical Cemented Tibia Drill Bit 15.7mm Dia. x 58mm.

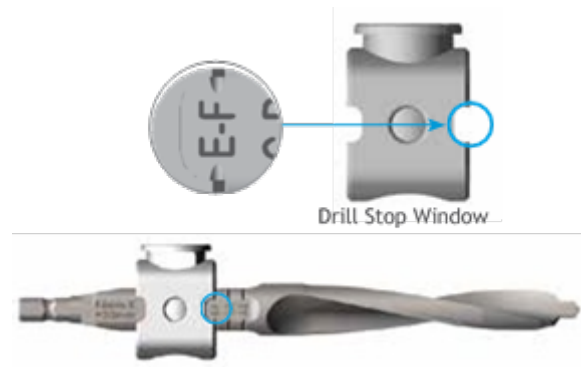

**Figure 19**

- **Technique Tip:** Verify that the cemented tibial drill stop collar is locked on the Persona Cemented Tibial Drill, 15.7 mm or Cemented Tibia Drill Bit 15.7mm Dia. x 58mm (43-5399-058-14) by attempting to slide the cemented tibial drill stop collar on the cemented tibial drill by hand. The cemented tibial drill stop collar will make an audible click when it locks on the drill.
3. Use the Persona Cemented Tibial Drill, 15.7 mm (42-5399-018-10) to create a pilot hole by positioning the cemented tibial drill stop collar in the proper position and drilling through the cemented tibial drill guide until the cemented tibial drill stop collar contacts the cemented tibial drill guide (Figure 17). After drilling is complete, remove the Persona Cemented Tibial Drill.
  4. Using the Canary Medical Cemented Tibia Drill Bit 15.7mm Dia. x 58mm, position the cemented tibia drill stop collar in the proper position and drill through the cemented tibia drill guide until the cemented tibia drill stop collar contacts the cemented tibia drill guide (**Figure 20**).

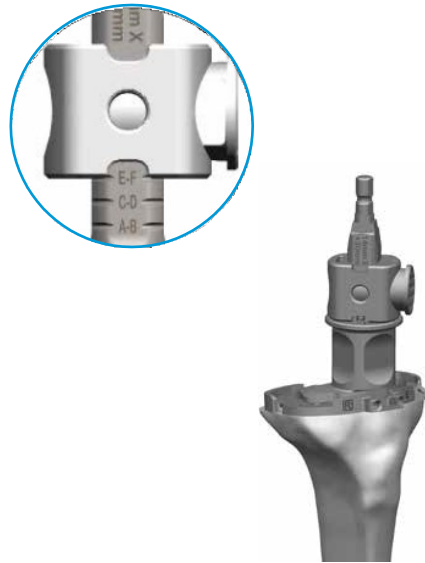

**Figure 20**

5. After drilling is complete, remove the cemented tibia drill and cemented tibia drill guide from the cemented tibia sizing plate.

**CAUTION: DO NOT** use the Canary Medical Cemented Tibia Drill Bit 15.7mm Dia. x 58mm prior to creating a tibial pilot hole with the Persona Cemented Tibial Drill, 15.7 mm.



☰ **Technique Tip:** Insert the Persona Cemented Tibial Drill, 15.7 mm or Canary Medical Cemented Tibia Drill Bit 15.7mm Dia. x 58mm into the cemented tibial drill guide prior to starting the drill. Hold the cemented tibial drill guide flush against the cemented tibial sizing plate while drilling.

☰ **Technique Tip:** When drilling, if you feel that excessive contact with the bone cortex is occurring, stop drilling and remove the drill, guide, and sizing plate. Use the Canary Medical provisional stem extension construct to check whether the fit in the bone is appropriate to allow use of the canturio™ te. Downsize the tibial base plate if a shorter tibial keel is needed.

## 12. Broaching the Tibia

**Table 8** lists the instrumentation used in this step.

**Table 8**

Instrumentation	Image	Catalogue Number
Persona Cemented Tibial Broach Size EF		42-5399-022-05
Persona Cemented Tibial Broach Inserter/ Extractor Handle		42-5399-023-00
Persona Cemented Tibial Sizing Plate Size F Right		42-5399-075-02

1. Insert the correct-sized cemented tibial broach into the cemented tibial broach inserter/extractor handle (**Figure 21**).

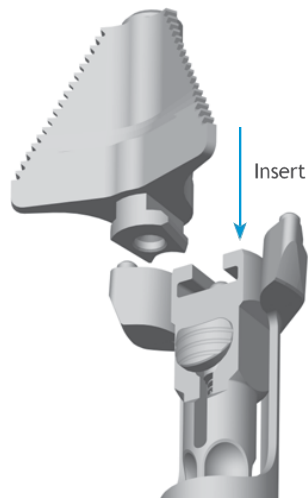

**Figure 21**

2. Retract the impactation head until it locks in the fully retracted position, which will facilitate placement on the cemented tibial sizing plate.
3. After seating the cemented tibial broach inserter/extractor handle on the cemented tibial sizing plate, tap the impactation head once to seat the cemented tibial broach.

4. Impact the cemented tibial broach inserter/extractor handle assembly with care to prevent fracture of the tibia (**Figure 22**). Impact until the impaction head bottoms out on the cemented tibial broach inserter/extractor handle stop (**Figure 22** inset).



**Figure 22**

5. While holding the cemented tibial broach inserter/extractor handle, impact the extraction button to remove the cemented tibial broach from the bone (**Figure 23**). Avoid dislodging the cemented tibial sizing plate when removing the cemented tibial broach inserter/extractor handle.



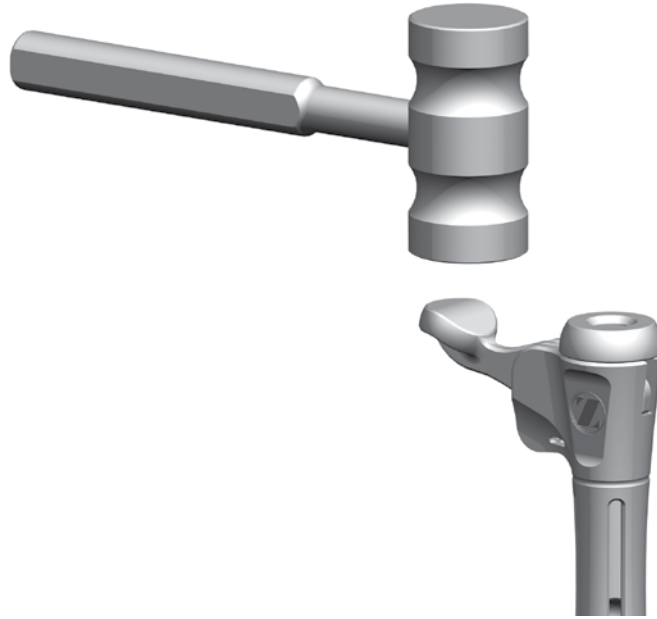

*Figure 23*

**WARNING:** Ensure that no metallic debris is present on the magnetic feet of the cemented tibial broach inserter/extractor handle as this may inhibit the mating with the cemented tibial sizing plate and may introduce debris into the surgical site.







☹ **Technique Tip:** Make sure that the cemented tibial broach inserter/extractor handle remains flush against and in full contact with the cemented tibial sizing plate and that the cemented tibial broach inserter/extractor handle does not tip during impaction. The orientation of the cemented tibial broach inserter/extractor handle is important to ensure proper and complete broaching resulting in full seating of the tibial implant on the bone.

☹ **Technique Tip:** **DO NOT** extract with mallet blows on either the medial or lateral side of the under surface of the impaction head of the cemented tibial broach inserter/extractor handle. **DO NOT** attempt to extract the cemented tibial broach with a horizontal or angled blow on any side of the cemented tibial broach inserter/extractor handle.

## 13. PROVISIONAL ASSEMBLY AND TRIALING

**Table 9** lists the instrumentation used in the steps in this section.

*Table 9*

Instrumentation	Image	Catalogue Number
2.5 mm Male Hex Driver		42-5099-025-00
25 mm x 2.5 mm Female Hex Screw		42-5099-025-25
Persona 14 mm x +30 mm Stemmed Tibia Provisional		42-5321-075-02
Canary Medical Straight Taper Stem Provisional 14 x 58mm		43-5571-058-14
Tibial Provisional Extractor		00-5977-017-00
CPS Lock Down Screw, Short		42-5376-001-00
CPS Lock Down Screw, Long		42-5376-001-01

### 13.1. Assembling the Canary Straight Taper Stem Provisional to the Persona Stemmed Tibial Provisional

When assembling the Canary Medical Straight Taper Stem Provisional 14 x 58mm with the Persona Stemmed Tibia Provisional:

1. Place the Persona component with the tibia tray facing down on a padded surface.
2. Thread the Canary Medical component into the female end of the Persona component (**Figure 24**).

3. Hand tighten.

**NOTE:** Thread the tapered stem provisional in first before trialing the knee using the Constrained Posterior Stabilized (CPS) TASP lockdown screw.

**NOTE:** Only hand-tighten the Canary Medical Straight Taper Stem Provisional 14 x 58mm.



*Figure 24*

## 13.2. Using the Canary Medical Stemmed Tibial Provisional Construct

When using the Canary Medical stemmed tibial provisional:

1. Assemble the stemmed tibial provisional to the tibial provisional extractor and insert in the prepared tibial bone.

**NOTE:** For additional fixation of the fully seated provisional, insert a 25 mm x 2.5 mm screw (2.5 mm female hex) with the 2.5 mm male hex driver through a screw fixation hole located in the medial and/or lateral compartments of the stemmed tibia provisional (**Figure 25**).

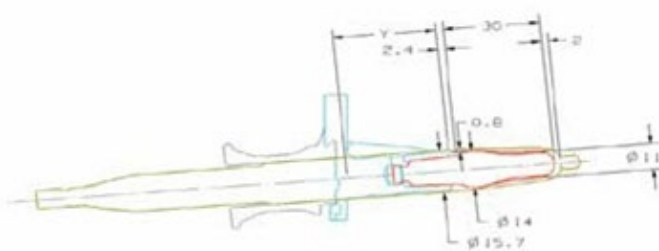

**Figure 25**

**WARNING: DO NOT** use 48 mm screws for cemented tibial sizing plate fixation. 48 mm screws are not recommended due to the potential for bone perforation.

The Persona Tibial Keel length ranges from 23.4 mm to 40 mm (**Figure 26**). The Canary Tibial Extension adds 58 mm to the length of the tibial keel nominally when assembled (**Figure 26**).

Refer to **Table 10** for the depth of the Persona Stem Tibia as illustrated in **Figure 26**.



**Figure 26 (Dimensions in mm)**

Reference Table 10 below for the appropriate tibia-to-stem compatibility. The canturio Tibial Extension is compatible with all Persona Cemented Stemmed Tibial Plates.

**Table 10: Persona with Canary Medical Tibial Extension Compatibility Chart**

Tibia Size	Y (Figure 26) mm	Canturio™ Tibial Extension
A	23.4	14 mm x +58 mm
B	23.4	
C	27.7	
D	27.7	
E	32	
F	32	
G	36	
H	36	
J	40	

# 14. Activating the CTE Implant

After the CTE implant has been introduced into the sterile field, and before assembly with the Persona tibial plate, use the steps below to activate the CTE implant.

1. Place the OR Base Station within 6 feet of the CTE implant. Connect the USB cable to the OR Base Station and Laptop. Connect the Barcode Scanner to the Laptop.
2. Plug the Laptop into a power outlet (if needed) and turn on the Laptop.
3. The Canary Operating Room Application (OR App) will start automatically.
4. Ensure the OR Base Station and Laptop are connected. This is indicated by the green “Base Station” icon at the top of the Laptop screen.
5. Ensure an Internet connection has been established and the OR App is connected to the Canary Cloud. This is indicated by the green Internet and Cloud icons at the top of the Laptop screen.
6. Click on the image of the implant in the center of the screen.
7. Enter your authorized Username and Password and click the “Login” button. This will take you to the Main Menu screen. **Figure 27.** Click on the “Activate Implant” Icon.

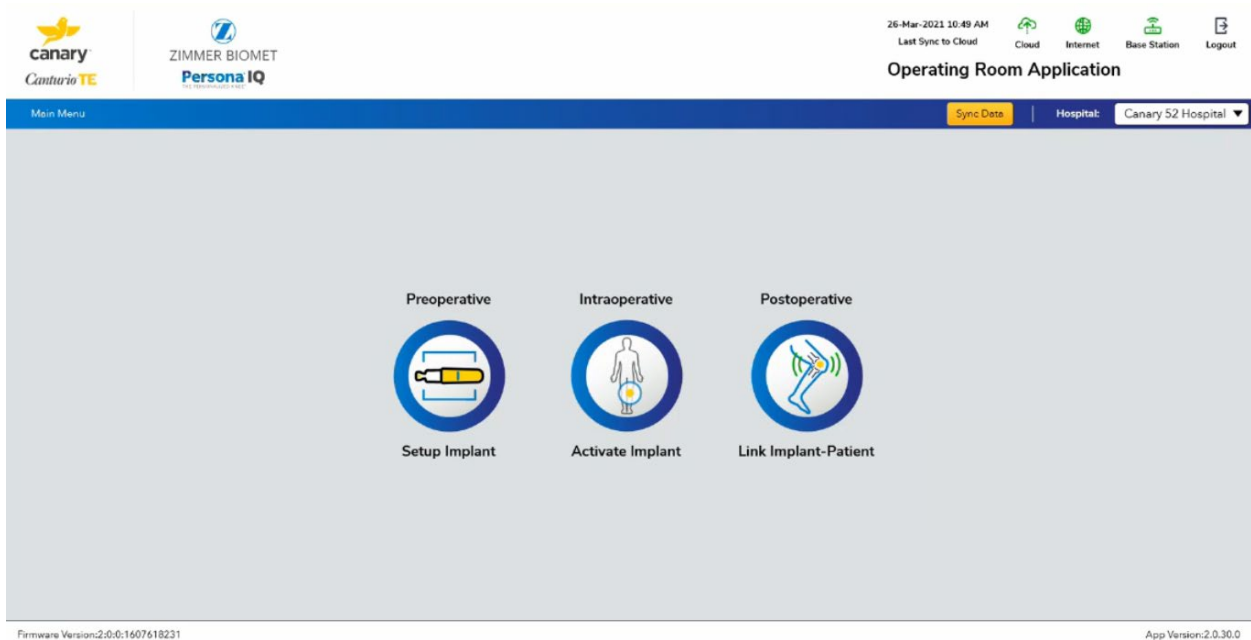

**Figure 27: Main Menu**

8. Click in the text box and enter or scan the CTE Serial Number, then click “OK.” **Figure 28.**

**NOTE:** If scanning, place the barcode scanner over the 2D bar code as shown in the example image below.

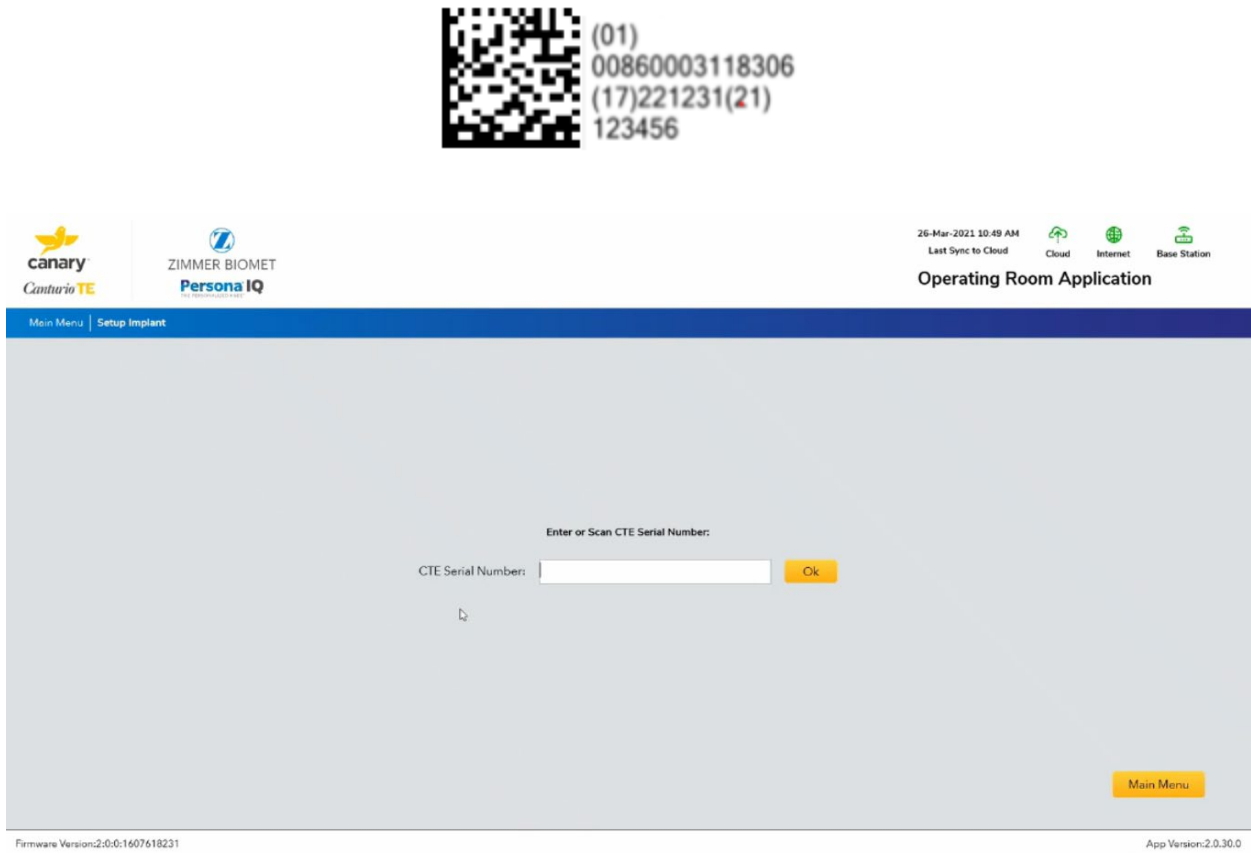

Figure 28: Enter or Scan CTE Serial Number

9. Click “Activate.” Figure 29.

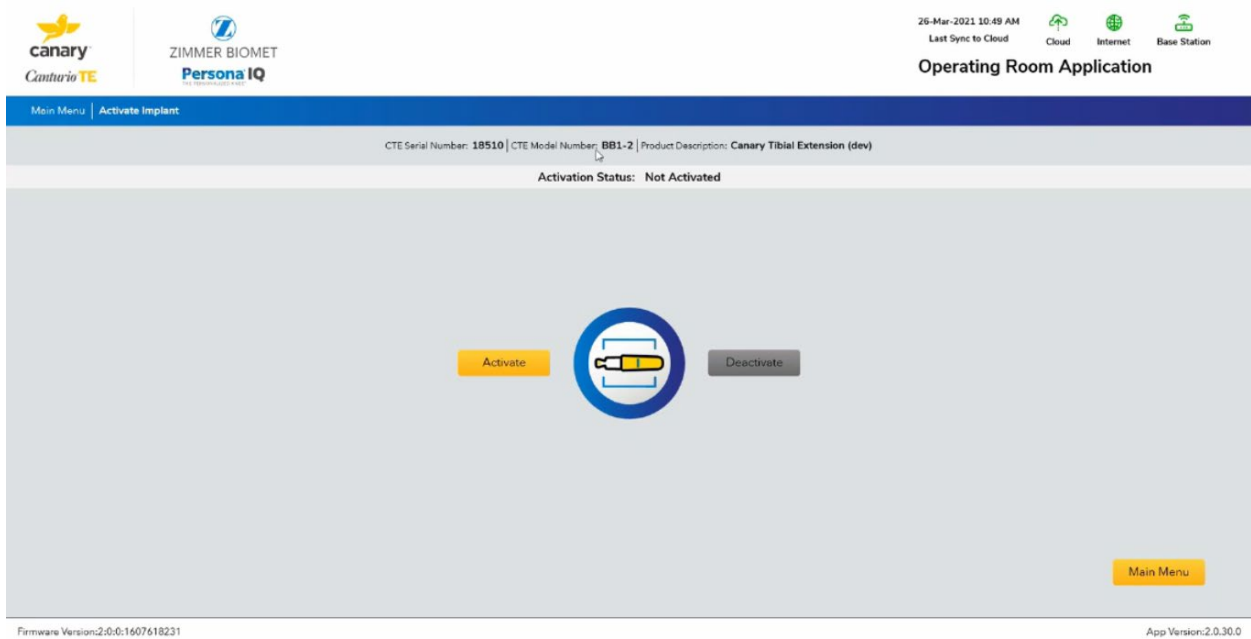

Figure 29: Activate

# 15. Assembling the CTE Implant with the Persona Tibial Plate

Table 11 lists the instrumentation used in the steps in this section.

Table 11

Instrumentation	Image	Catalogue Number
Persona Cemented Stemmed Tibial Plate Sizes F Right		42-5320-075-02
canturio™ Medical Tibial Extension (CTE) Implant		43-5570-058-14
Persona Femoral Set Screw Hex Driver		00-5987-071-00
Canary Medical CTE Impaction Sleeve		43-5399-001-14



## 15.1. Preparing the Canturio™ Tibial Extension (CTE)

To attach the CTE Implant to the Persona Tibial Plate:

1. Position the Persona Tibial Plate with the face plate down on a padded surface (**Figure 30**).

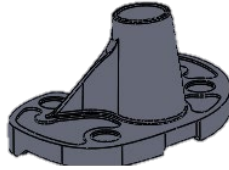

*Figure 30*

**NOTE:** The locking mechanism between the Persona Tibial Plate and the CTE Implant is a combination of a taper and a set screw.

2. Using the hex driver, loosen the locking set screw from the Persona Tibial Plate by backing the set screw out only far enough so that you can remove the plastic plug. Remove the plastic plug within the taper (**Figure 31**). Take care not to drop or lose the set screw.

**NOTE:** Dispose of the plastic plug as medical waste.

3. Confirm that the set screw is not going to interfere with the CTE implant.

**CAUTION:** Check to ensure that the set screw has not migrated or fallen into the Persona Tibial Plate or package prior to inserting the CTE Implant into the Persona Tibial Plate.



*Figure 31*

4. Align the alignment mark on the CTE Implant to the alignment mark on the Persona Tibial Plate, and insert the CTE implant taper into the Persona Tibial Plate taper until fully seated (**Figure 32**).

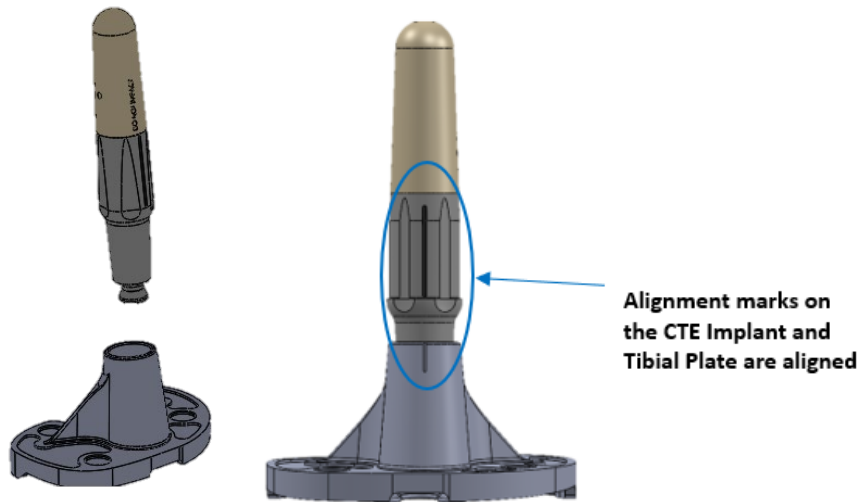

*Figure 32*

5. When a "snug" fit is achieved, place the assembly on a surgical cart with the tibial plate face down on a padded surface.
6. Place the Impaction Sleeve over the CTE Implant and Tibial Plate assembly until the Impaction Sleeve stops on the CTE Implant. Impact on the Impaction Sleeve with a two- pound mallet solidly multiple times until the CTE Implant is fully seated in the Persona Tibial Plate (**Figure 33**).

**CAUTION: DO NOT** impact directly on the CTE to insert. Only use the Impaction Sleeve to apply impact force.

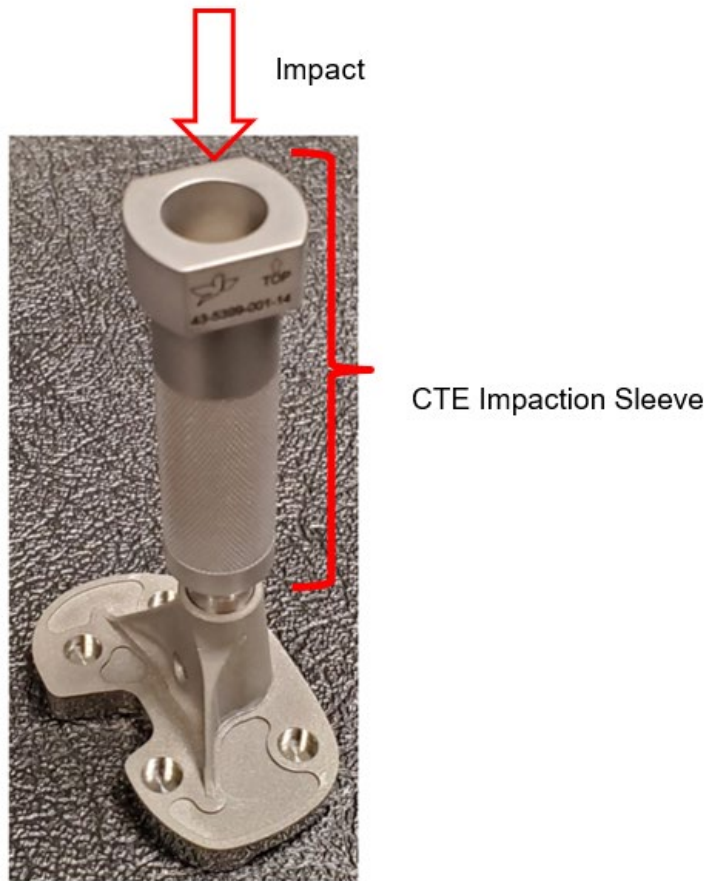

*Figure 33*

7. Once the CTE Implant is seated into the Persona Tibial Plate, hand-tighten the set screw and torque with the femoral set screw hex driver (**Figure 34**).



*Figure 34*

8. Verify the CTE Implant is fully seated after impacting and torquing the set screw (**Figure 35**).



**Figure 35**

**CAUTION:** The Canary Medical Tibial Extension is compatible with the primary Persona Cemented Stemmed Tibial Plates. **DO NOT** use with the Persona Revision System, or with Vanguard, NexGen, or Natural-Knee II Tibial Plates. For cemented use only.

**Technique Tip:** **DO NOT** implant the CTE without the set screw. Have a spare set screw available at each surgery. The part number of the set screw is 00-5988-090-00.



**CAUTION:** The femoral set screw hex driver is designed to limit the amount of torque which can be applied to the screw and is designed to break off if over-torqued. Torque by hand only.

**OPTIONAL:** After completing the assembly, run Self-Test from the Implant Self-Test instructions in Section 9 to verify the CTE implant is still working.

# 16. Implanting the CTE and Persona Assembly

Table 12 lists the instrumentation used in this step.

Table 12

Instrumentation	Image	Catalogue Number
Persona Quick Connect Handle		00-5901-034-00
Persona Tibial Impactor Head		00-5901-033-00
Persona Cemented Stemmed Tibial Plate Sizes F Right		42-5320-075-02

**ⓘ Technique Tip:** Prior to cementing the implants, remove the provisionals and use pulse lavage to remove debris from the resected bone surfaces and the joint space.

In this step, the final components are implanted, and the Persona tibial bearing is secured to the implanted tibial plate. When using cemented components, it is recommended to use two batches of cement.

After the implants have been chosen, make a final check to ensure that all components are compatible. If the resected surfaces of the tibia and/or femur are sclerotic, drill multiple holes with a small drill (2.0 mm–3.2 mm) to improve cement intrusion. Mix cement following the manufacturer's guidelines for cement preparation including but not limited to mix, work, and set times.

## 16.1. Tibial Plate

Sublux the tibia anteriorly to allow adequate clearance to insert the tibial implant into the prepared bone. **DO NOT** apply substances other than bone cement to the tibial implant (e.g., **DO NOT** dip implant into antibiotics or other substances). Keep the implant clean and free of debris prior to cementing. At a minimum, place a layer of cement on the underside of the tibial baseplate, around the keel, around the metal component of the CTE implant up to the PEEK-Titanium interface (excluding the PEEK nosecone) as shown in Figure 36, and on the resected tibial surface. When increased fixation is desired, you can use full cementation around the CTE Implant (including the PEEK nosecone) and in the tibial IM canal without affecting the performance or wireless communications of the CTE Implant.

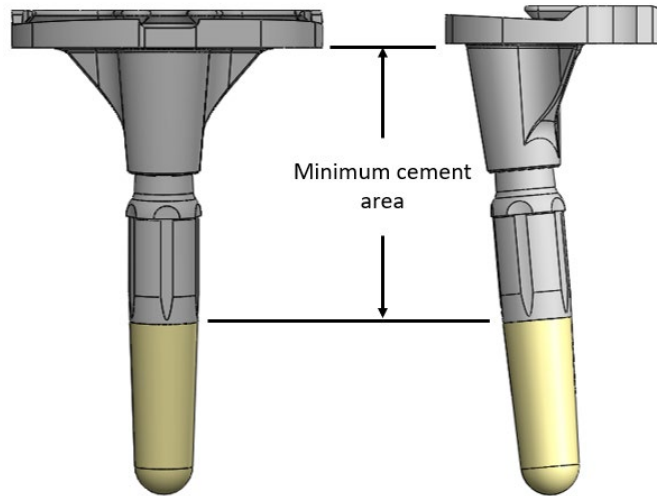

*Figure 36*

Assemble the quick connect handle to the tibial impactor head. Unlock collar and hold, insert handle into impactor head, release collar, and rotate handle until “click” is heard (**Figure 37**).



*Figure 37*

Position the tibial plate onto the tibia and use the tibial impactor to impact it until fully seated (**Figure 38**).



*Figure 38*

Thoroughly remove any excess cement in a consistent manner. Allow the cement to fully cure before performing a trial ROM or inserting the bearing per the manufacturer's recommended guidelines.

OPTIONAL: After completing implantation, run Self-Test from the Implant Self-Test instructions in Section 9 to verify the CTE implant is still working

## 17. Linking the CTE and Persona IQ® Implant Components to the Patient

After the surgery is complete, use the OR PC Application and Barcode Scanner to link the patient’s implant components with the patient in the patient’s account.

1. Connect the USB cable to the Base Station and Laptop. Connect the Barcode Scanner to the Laptop.
2. Plug the Laptop into a power outlet (if needed) and turn on the Laptop.
3. The Canary Medical Operating Room Application (OR App) will start automatically.
4. Ensure the OR Base Station and Laptop are connected. This is indicated by the green “Base Station” icon at the top of the Laptop screen.
5. Ensure an Internet connection has been established and the OR App is connected to the Canary Medical Cloud. This is indicated by the green Internet and Cloud icons at the top of the Laptop screen.
6. Click on the image of the implant in the center of the screen.
7. Enter your authorized Username and Password and click the “Login” button. This will take you to the Main Menu screen. (Figure 39)
8. Under “Postoperative,” click on the “Link Implant – Patient” icon. Figure 39.

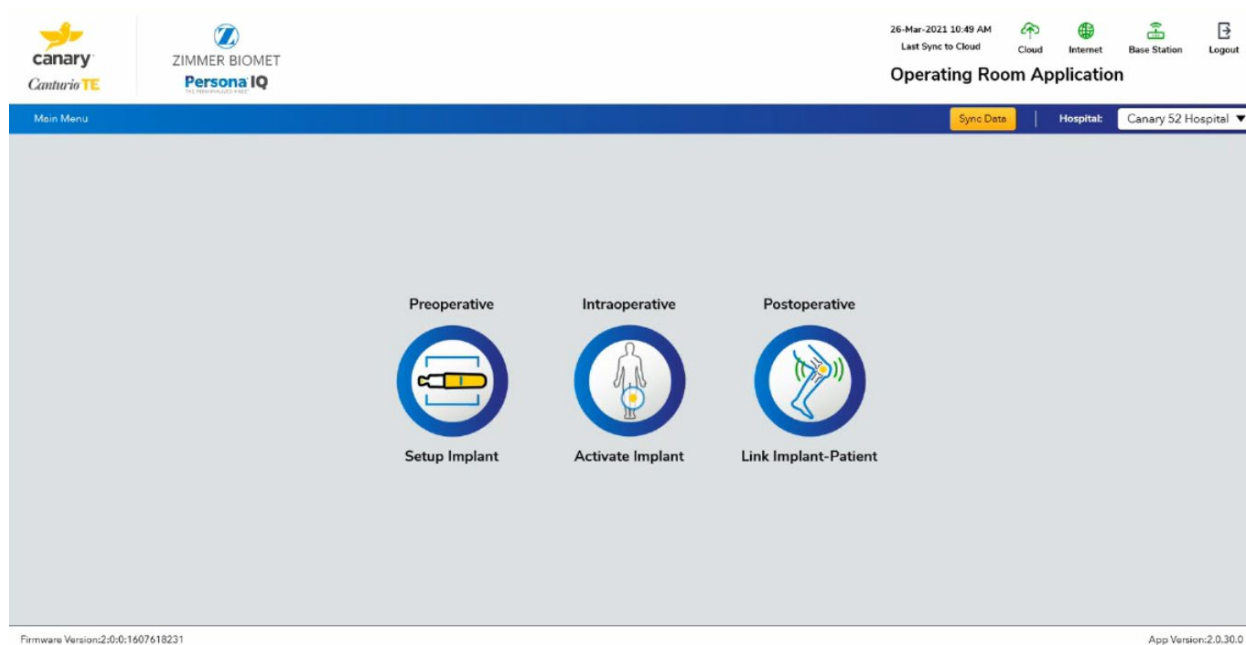

Figure 39: Main Menu



9. Choose the patient's name from the list. **Figure 40.**
- a. If a patient's name is not on the list, click "Manually Enter Patient."

The screenshot displays the 'Operating Room Application' interface. At the top, there are logos for 'canary Canturio TE' and 'ZIMMER BIOMET Persona IQ'. The status bar shows the date and time as '26-Mar-2021 10:49 AM' and 'Last Sync to Cloud'. There are also icons for 'Cloud', 'Internet', and 'Base Station'. The main content area features a 'Patient List' table with columns for 'Patient First Name', 'Patient Last Name', 'DOB', 'Implant Location', 'Surgery Date', and 'Surgery Time'. Two patient entries are visible, both with 'Demo' as the last name and '01-Feb-1970' as the DOB. The first entry is for a 'Right Knee' implant, and the second is for a 'Left Knee' implant. Both surgery dates are '26-Mar-2021' and the time is '02:00 PM'. A 'Manually Enter Patient' button is located in the top right corner of the table area. A 'Main Menu' button is located in the bottom right corner of the interface. The footer contains the text 'Firmware Version:2.0.0:1607618231' on the left and 'App Version:2.0.30.0' on the right.

Patient First Name	Patient Last Name	DOB	Implant Location	Surgery Date	Surgery Time
Patient	Demo	01-Feb-1970	Right Knee	26-Mar-2021	02:00 PM
Patient	Demo	01-Feb-1970	Left Knee	26-Mar-2021	02:00 PM

**Figure 40: Choose Patient from List or Click "Manually Enter Patient"**

- b. If manually entering patient's information, (**Figure 41**), click "Next" when finished.



08-Jun-2021 07:49 AM  
Last Sync to Cloud



Cloud



Internet



Base Station

## Operating Room Application

Main Menu | [Link Implant-Patient](#)

### Manually Enter Patient

Patient First Name*	<input type="text"/>
Patient Last Name*	<input type="text"/>
DOB*	<input type="text" value="08-Jun-1960"/>
Hospital Name*	<input type="text" value="ZB Training Hospital"/>
Surgery Date*	<input type="text" value="08-Jun-2021"/>

\* Required Fields

Cancel

Next

Firmware Version:2:1:0:1617655881

App Version:2.0.44.0

Figure 41: Manually Enter Patient Information

10. Choose the implant location (left or right knee). **Figure 42.**

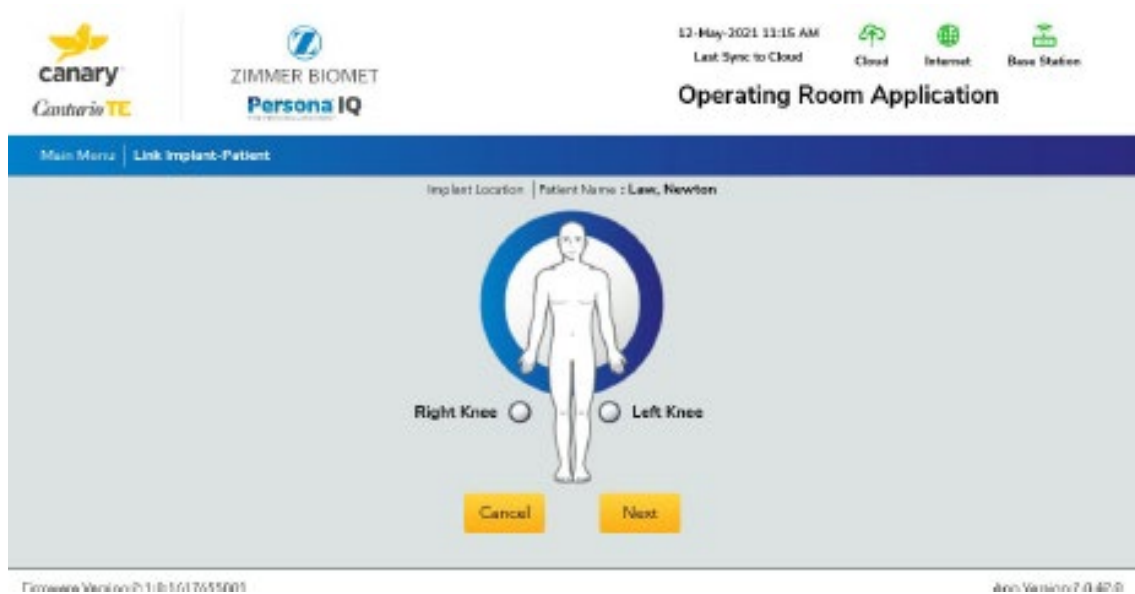

**Figure 42: Choose Implant Location**

11. Click “Right Knee” or “Left Knee.”
12. Click in the text boxes to enter or scan the serial numbers of the CTE and other implant components. When finished, click “Submit” to save the information to the patient’s account.

**Figure 43.**

**NOTE:** If scanning, place the barcode scanner over the 2D bar code on the label, as shown in the example image below.



Main Menu | Link Implant-Patient

Implant Location : **Right Knee** | Patient Name : **Demo, Patient**

Component Detail	Right Knee CTE Serial Number
CTE serial number*	<input type="text"/> <input checked="" type="checkbox"/> Smart Knee
Femoral component*	<input type="text"/>
Tibial component*	<input type="text"/>
Linear component*	<input type="text"/>
Patella component	<input type="text"/>

\* Required Fields

Cancel Submit

Firmware Version:2.0.0:1607618231 App Version:2.0.30.0

Figure 43: Add Component Information

All content herein is protected by copyright, trademarks and other intellectual property rights, as applicable, owned by or licensed to Zimmer Biomet or its affiliates unless otherwise indicated, and must not be redistributed, duplicated or disclosed, in whole or in part, without the express written consent of Zimmer Biomet. For indications, contraindications, warnings, precautions, potential adverse effects and patient counseling information, see the package insert or contact your local representative; visit [www.zimmerbiomet.com](http://www.zimmerbiomet.com) for additional product information.

This material is intended for health care professionals. Distribution to any other recipient is prohibited.

Zimmer Biomet does not practice medicine. This technique was developed in conjunction with healthcare professionals. This document is intended for surgeons and is not intended for laypersons. Animations and virtual reality are provided as a visual guide based on surgical techniques. Each surgeon should exercise his or her own independent judgment in the diagnosis and treatment of an individual patient, and this information does not purport to replace the comprehensive training surgeons have received. As with all surgical procedures, the technique used in each case will depend on the surgeon's medical judgment as the best treatment for each patient. Results will vary based on health, weight, activity and other variables. Not all patients are candidates for this product and/or procedure. Caution: Federal (USA) law restricts this device to sale by or on the order of a surgeon. Rx only.

©2021 Zimmer Biomet

JDoctor canturio is an imaginary doctor with a fabricated surname.

HCP canturio is an imaginary health care provider with a fabricated surname.

Canary Medical Logo, Canary Medical, CANARY *canturio*<sup>™</sup>, *Canturio*<sup>™</sup>, and CHIRP are the exclusive property of Canary Medical and its affiliates.

Persona IQ<sup>®</sup> and The Personalized Knee<sup>®</sup> are registered trademarks of Zimmer, Inc. The Smart Knee<sup>™</sup> is a trademark of Zimmer, Inc. All other trademarks are the property of their respective owners.

This material is intended for health care professionals. Distribution to any other recipient is prohibited.

©2021 Canary Medical Inc. All Rights Reserved.

canturio<sup>™</sup>te Manufactured for:

Canary Medical USA LLC

2710 Loker Ave. West, Suite 350

Carlsbad, California 92010

Customer Service: 1-833-722-6279 or 1-833-7CANARY

[www.canarymedical.com](http://www.canarymedical.com)

---

canturio<sup>™</sup>te Exclusively Distributed by:

Zimmer, Inc.

1800 West Center St.

Warsaw, Indiana 46581-0587 USA

[zimmerbiomet.com](http://zimmerbiomet.com)

---

Persona<sup>®</sup> Knee Legal Manufacturer:

Zimmer, Inc.

1800 West Center St.

Warsaw, Indiana 46581-0587 USA

[zimmerbiomet.com](http://zimmerbiomet.com)

K01-CTE-300005, Rev. B  
3640.1-US-en-Issue Date 2021-08-12