

A.L.P.S.[®] Distal Tibia Plating System

Surgical Technique



A.L.P.S. Distal Tibia Plating System

Contents

The Distal Tibia Locking Plate System	5
F.A.S.T. Guide and F.A.S.T. Tabs Technologies.....	7
Locking, Non-Locking, and Multi-Directional Screw Options	9
Introduction	11
Anterolateral Distal Tibia Locking Plate	12
Anterolateral Plate Specifications	13
Medial Distal Tibia Locking Plate.....	14
Medial Plate Specifications	15
Staged Protocol.....	16
Surgical Approaches.....	17
Internal Fixation of Fibula and Malleolus.....	19
Reconstruction of the Tibia	20
Plate Selection.....	21
Plates	22
Application of the Plates	24
Screw Insertion.....	26
Ordering Information	33

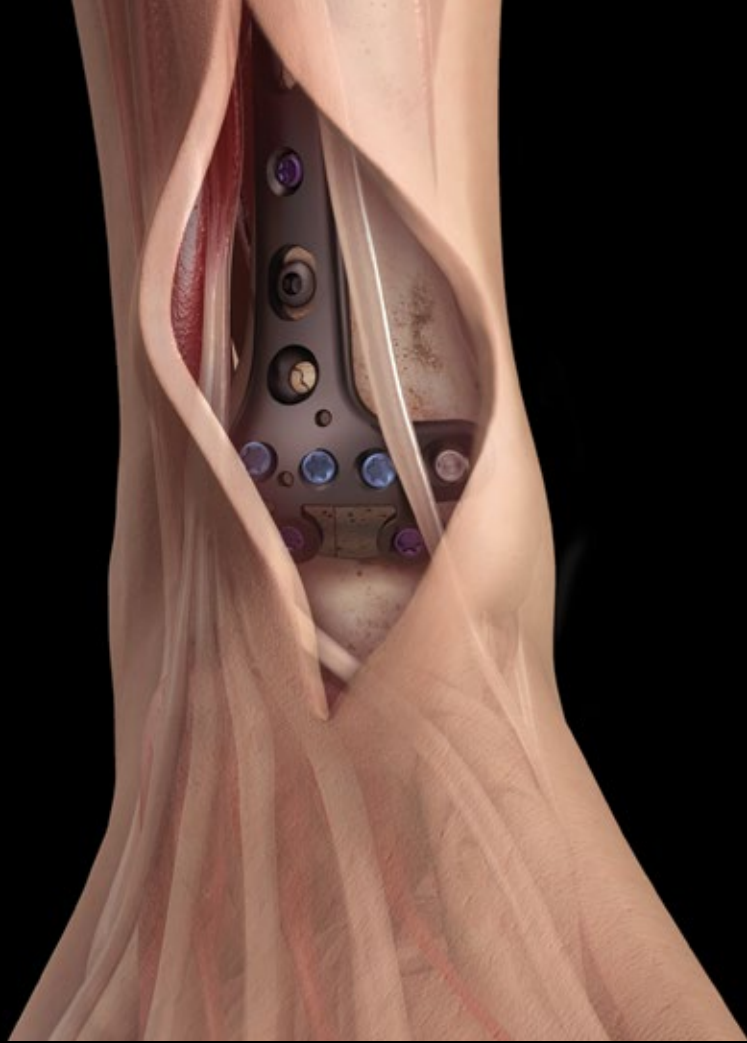

A.L.P.S. Distal Tibia Plating System

Low Profile Anatomically Contoured

The Distal Tibia Locking Plate System

- A low-profile designed to help minimize potential discomfort and soft tissue irritation
- Contoured plates mimic the anatomy of the distal tibia
- Anterolateral plate is available in wide and narrow widths to suit patient size
- Bullet tip designed to minimize soft tissue disruption during insertion
- Plate insertion handle simplifies submuscular application

For distal tibia procedures that often involve complex fractures and minimal tissue coverage, the Distal Tibia Plating System provides both strength and low-profile advantages. Having a slim profile with the capability to contour in-situ, these plates may be used successfully to treat even the most challenging cases.

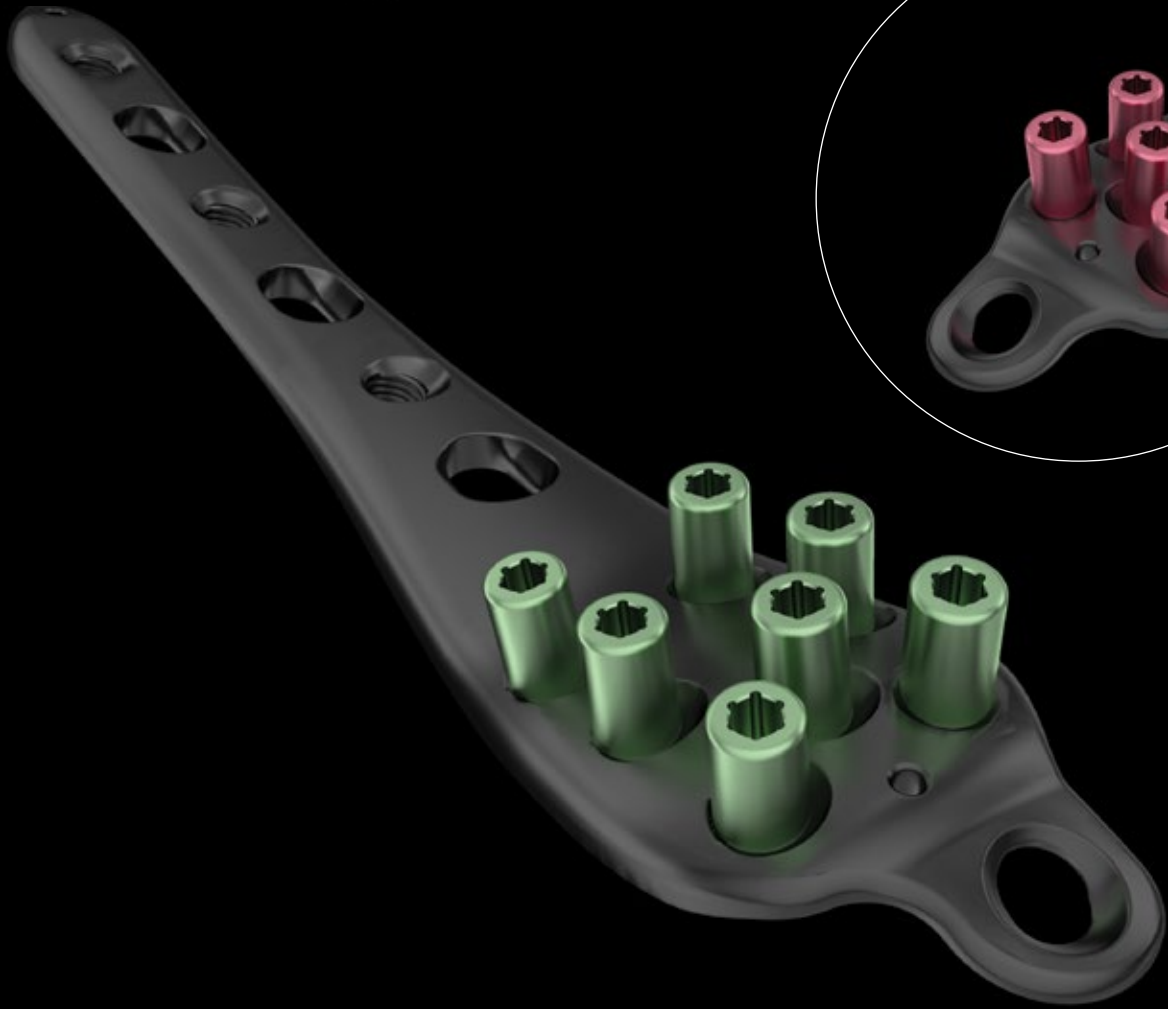
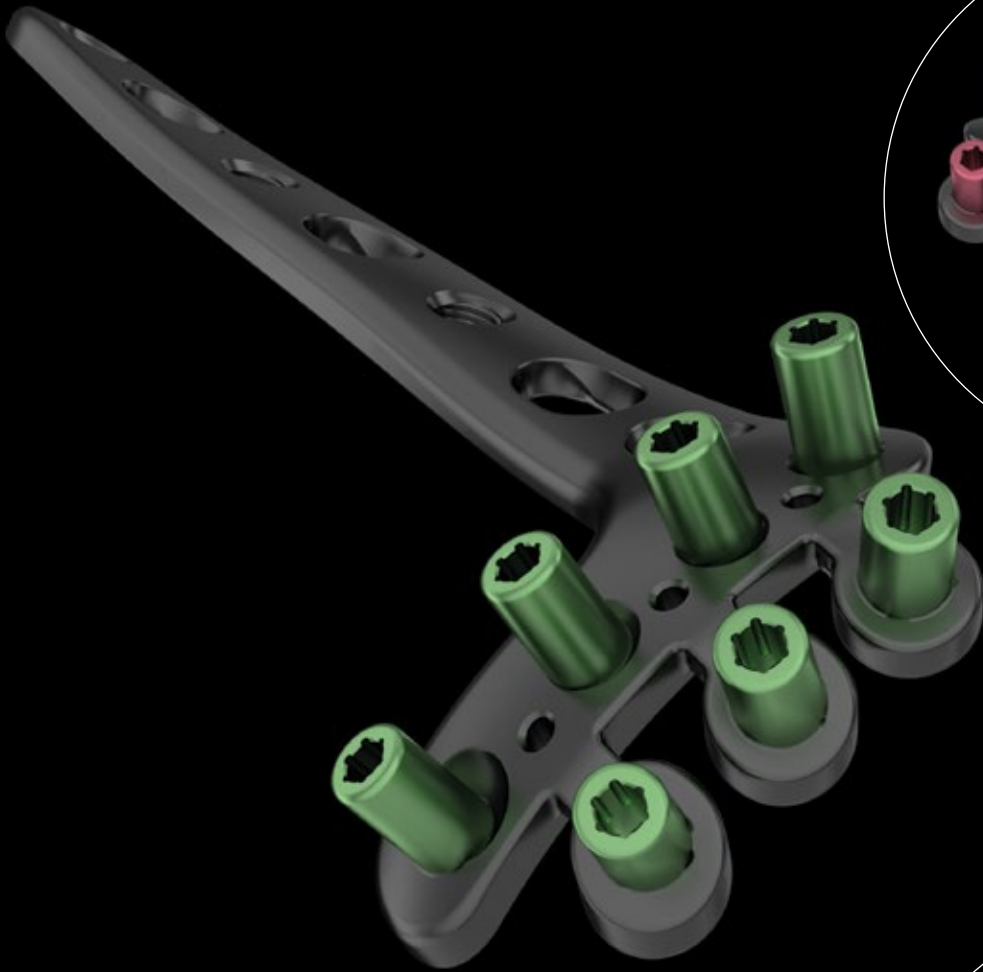

A.L.P.S. Distal Tibia Plating System

Fast, Accurate Surgeries

F.A.S.T. Guide[®] and F.A.S.T. Tabs[®] Technologies

F.A.S.T. Guide

- Facilitates accurate drilling
- Pre-loaded and disposable
- Saves time in the OR since no intraoperative assembly is required
- Color-coded guides make identification easy: Red guide=Right, Lime guide=Left

F.A.S.T. Tabs

- Distal tabs of the Anterolateral Plate easily contour to conform to the bone
- Threaded holes in the tabs of the Anterolateral Plate allow screws to lock to the plate, providing stability and support
- Interlocking alignment of distal screws can create a subchondral scaffold for rigid fixation

To facilitate surgical procedures even more, our Distal Tibia Plates come pre-loaded with Fixed Angle Screw Targeting Guides - F.A.S.T. Guide inserts - that direct the trajectory of the drill right into the plate. Additionally, our F.A.S.T. Tabs technology provides a robust interlocking construct for bone fragments.

Note: The F.A.S.T. Guide inserts are NOT to be removed prior to sterilization.



A.L.P.S. Distal Tibia Plating System

Versatility in construct

Locking, non-locking, and multi-directional screw options

- Choose Locking, Non-Locking, or Multi-Directional Screws according to need
- All options available in each construct
- Tapered, threaded screws lock into position when tightened to establish a fixed angle construct for strong fixation or when optimal screw purchase is required
- Locking Multi-Directional Screws (MDS) allow for up to 15 degrees of angulation from center
- Non-Locking Screws can be positioned and used in compression, neutral, and buttress modes

Particularly helpful in challenging fracture cases, the interlocking screw construct of the Distal Tibia Plates provides both versatility and strength.



Introduction

The Zimmer Biomet A.L.P.S. Distal Tibia Plating System represents the next generation in anatomic plate design. It combines the benefits of low-profile titanium plate metallurgy with the advantages of multiplanar locked screw technology. These features allow the formation of a three dimensional matrix of fixed and variable angle screws to create a true subchondral scaffold that can provide strong fixation in comminuted fractures or osteopenic bone.

The Zimmer Biomet A.L.P.S. Distal Tibia Plating System features Type 2 Anodized Titanium Alloy low-profile, anatomically contoured implants. In distal tibial surgery where soft tissue coverage is at risk, these low-profile plates are designed to minimize discomfort and soft tissue irritation matching the anatomy of the distal tibia, while still having the required strength.

The System features F.A.S.T. Guide and F.A.S.T. Tabs technology to facilitate surgical procedures and save time in the operating room. F.A.S.T. Guide inserts allow for accurate drilling and placement of screws. F.A.S.T. Guide come preloaded and do not require intraoperative assembly, which can result in significant time savings. F.A.S.T. Tabs are distal versatile tabs with threaded screw holes to lock small distal articular fragments to the plate. Screws placed in these locking holes create an intersecting three-dimensional scaffold to support the distal articular surface.

Additionally, the Zimmer Biomet A.L.P.S. Distal Tibia Plating System allows the use of locking, variable angle, and standard screws. This hybrid fixation concept allows the surgeon to stabilize the fracture either by the use of lag screw techniques through the plate, or by compression plating techniques. Locking screws serve to provide stability to comminuted, unstable metaphyseal fractures or in osteopenic bone.

The Medial Locking Plate is indicated for:

- Pilon Fractures: distal tibial intra-articular fractures
- High medial malleolar fractures
- Low boot type rotational distal extra-articular shaft fractures

The Anterolateral Locking Plate is indicated for:

- Distal intra-articular tibia fractures
- Proximal tibia fractures
- Proximal and distal humerus fractures

A.L.P.S. Distal Tibia Plating System

Anterolateral Distal Tibia Locking Plate

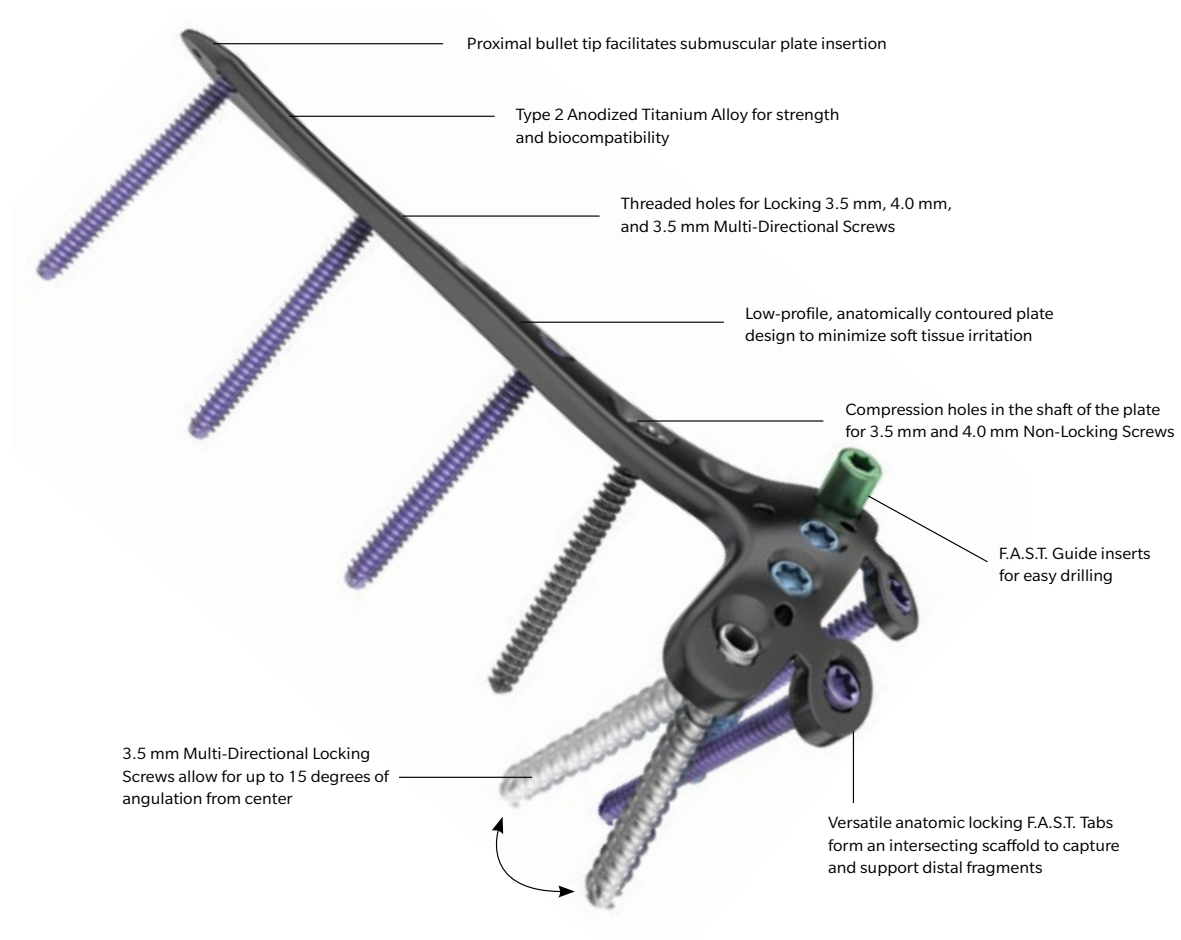

Non-Locking Screws



3.5 mm Cortical Screws



4.0 mm Cancellous Screws, Full Thread



4.0 mm Cancellous Lag Screws



4.0 mm Cannulated Cancellous Lag Screws

Locking Screws



3.5 mm Cortical Screws



4.0 mm Cancellous Screws



3.5 mm Multi-Directional Screws

Anterolateral Plate Specifications

Anterolateral Plate	Wide	Narrow
Head Width	39 mm	34 mm
Head Thickness	3 mm	3 mm
Tab Thickness	3 mm	3 mm
Shaft Width	12 mm	12 mm
Shaft Thickness	3 mm	3 mm
Distance between center holes of shaft	14 mm	14 mm
Orientations	Left / Right	Left / Right
Lengths	6H, 9H, 12H, 15H	6H, 9H, 12H, 15H

3.5 mm Locking Cortical Screw:

- Large core diameter and shallow thread pitch for bending and shear strength
- Self-tapping tip minimizes the need for pre-tapping and eases screw insertion
- Tapered screw head helps ensure alignment of the screw head into the plate hole
- Tapered threaded head minimizes screw back-out and construct pullout
- T-15 drive
- Available in lengths of 10 – 70 mm

3.5 mm Locking Multi-Directional Screw:

- Cobalt-Chrome screw with large core diameter
- Multi-directional capability offers 15 degrees of angulation from center
- Creates own thread in plate to help provide strong and stable construct
- Screw head designed to prevent it from going through the threaded screw hole
- Self-tapping tip minimizes the need for pre-tapping and eases screw insertion
- 2.2 mm square drive
- Available in lengths of 20 – 60 mm

4.0 mm Locking Cancellous Screw:

- Self-tapping tip minimizes the need for pre-tapping and eases screw insertion
- Tapered screw head helps ensure alignment of the screw head into the plate hole
- Tapered threaded head minimizes screw back-out and construct pullout
- T-15 drive
- Available in lengths of 10 – 70 mm

A.L.P.S. Distal Tibia Plating System

Medial Distal Tibia Locking Plate

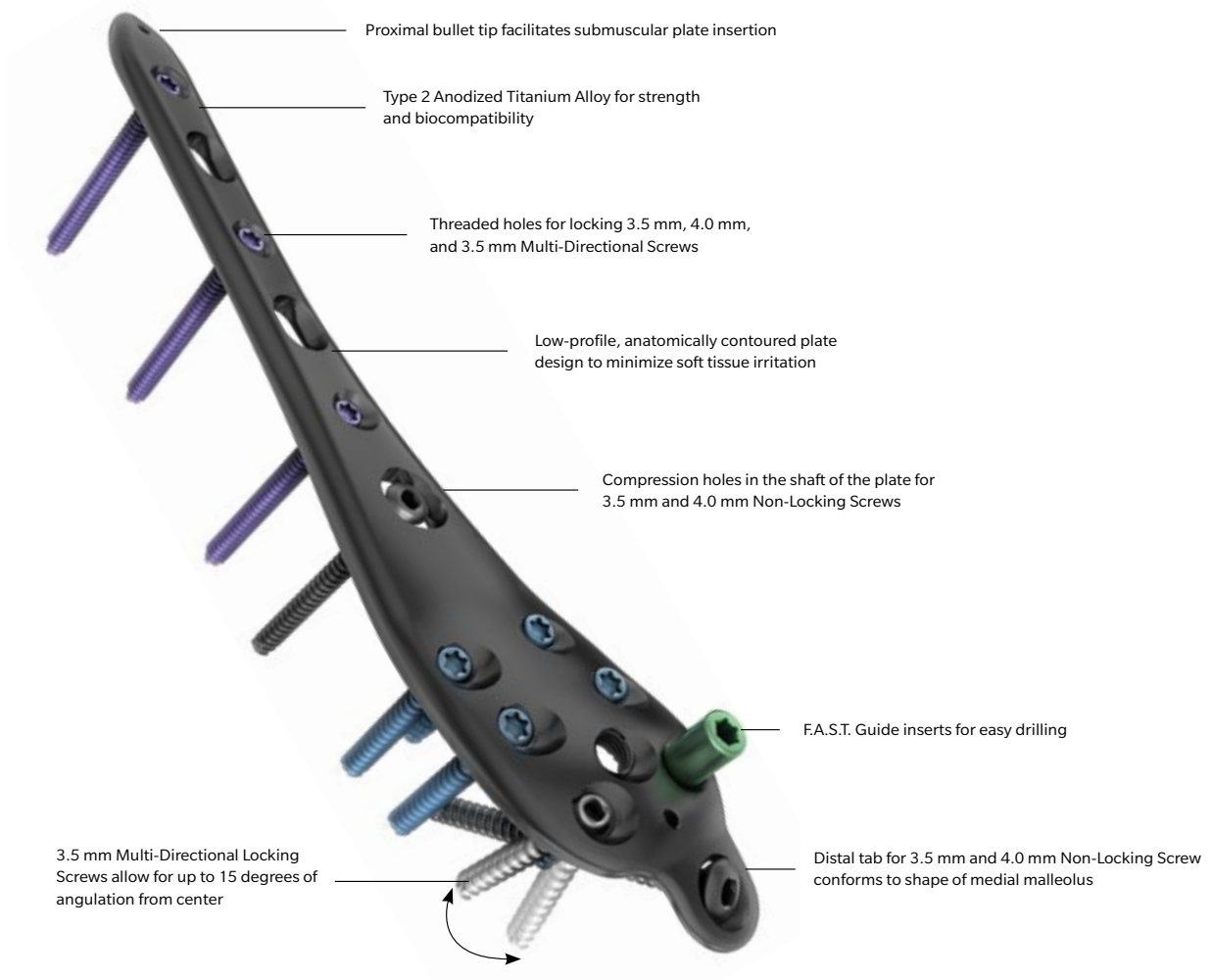

Non-Locking Screws



3.5 mm cortical screws



4.0 mm cancellous screws, full thread



4.0 mm cancellous lag screws



4.0 mm cannulated cancellous lag screws

Locking Screws



3.5 mm cortical screws



4.0 mm cancellous screws



3.5 mm multi-directional screws

Medial Plate Specifications

Medial Plate	
Head Width	23 mm
Average Head Thickness	3 mm
Tab Thickness	2 mm
Shaft Width	12 mm
Shaft Thickness	3 mm
Distance between center holes of shaft	14 mm
Orientations	Left / Right
Lengths	6H, 9H, 12H, 15H

3.5 mm Locking Cortical Screw:

- Large core diameter and shallow thread pitch for bending and shear strength
- Self-tapping tip minimizes the need for pre-tapping and eases screw insertion
- Tapered screw head helps ensure alignment of the screw head into the plate hole
- Tapered threaded head minimizes screw back-out and construct pullout
- T-15 drive
- Available in lengths of 10 – 70 mm

4.0 mm Locking Cancellous Screw:

- Self-tapping tip minimizes the need for pre-tapping and eases screw insertion
- Tapered screw head helps ensure alignment of the screw head into the plate hole
- Tapered threaded head minimizes screw back-out and construct pullout
- T-15 drive
- Available in lengths of 10 – 70 mm

3.5 mm Locking Multi-Directional Screw:

- Cobalt-Chrome screw with large core diameter
- Multi-directional capability offers 15 degrees of angulation from center
- Creates own thread in plate to help provide strong and stable construct
- Screw head designed to prevent it from going through the threaded screw hole
- Self-tapping tip minimizes the need for pre-tapping and eases screw insertion
- 2.2 mm square drive
- Available in lengths of 20 – 60 mm

A.L.P.S. Distal Tibia Plating System



Figure 1

When planning to treat a distal tibia fracture surgically using plates, application of a spanning external fixator should be performed as soon as possible.

Portable Traction

When planning to treat a distal tibia fracture surgically using plates, application of a spanning external fixator should be performed as soon as possible (Figure 1).

Pin placement distally is dependent on the type of frame employed. Proximally placed tibial pins should be away from planned incisions to avoid pin tracts possibly infecting the surgical site. When placing frames, the surgeon should verify that the tibial shaft is in acceptable alignment, as posterior subluxation of the talus and hindfoot can lead to pressure necrosis of the anterior skin. Once the multi-planar frame has been applied, the patient should undergo a CT scan, with sagittal and transverse reconstructions.

Zimmer Biomet's temporary spanning fixation device is TempFix[®]. It is offered with a U-ring (Cat. No. 8081-09-000 - Left, 8081-10-000 - Right) or without (Cat. No. 8081-11-000).

After review of the CT scans and plane films, a determination can be made regarding the correct surgical approach and plate application. The fibula should undergo internal fixation after the CT scan has been performed, in order to determine the location of the incisions.



Figure 2

One of three surgical approaches can be used.
An example of an Antero-Medial approach.

Surgical Approaches

Approaches include an antero-medial incision, a standard anterior incision, or the lateral Böhler approach. When plating the fibula through a standard lateral approach, the surgeon should identify the tibial incision first to avoid narrow skin bridges between the two incisions.

1. The Antero-Medial Approach

Begin at the level of the distal shaft of the tibia, just lateral to the anterior crest, and continue distally as far as needed, staying medial to the anterior tibial tendon. Take the skin together with the subcutaneous tissue and the periosteum in a full thickness flap to prevent separation of the medial skin from its periosteal blood supply. Expose the joint through major tears in the soft tissue envelope. If needed, the joint capsule can be incised in line with the skin incision, to visualize the articular surface. This approach offers the surgeon an excellent view of the medial and anterior distal tibia, but visualization of the lateral tibial articular surface will be limited (Figure 2).

A.L.P.S. Distal Tibia Plating System



Figure 3
Standard Anterior approach.



Figure 4
Lateral approach.

2. The Standard Anterior Approach

Make an 8 - 10 cm skin incision centered over the ankle, with most of the incision proximal to the joint. Distally, the incision stops at the level of the talo-navicular joint. Find and protect the superficial peroneal nerve, which crosses the wound from the lateral side. Incise the extensor retinaculum in line with the skin incision, and expose the anterior tibial (AT) and extensor hallucis longus (EHL) tendons. Locate and protect the anterior tibial artery and deep peroneal nerve just medial to the EHL tendon at the level of the joint. Move the neurovascular bundle laterally along with the EHL; the AT should be moved medially. This exposes the ankle capsule. The exposure of the joint should be through the major tears in the soft tissue envelope. Excellent visualization of the medial, and anterior tibial plafond are possible with this approach, but visualization of the lateral tibial plafond again is somewhat limited (Figure 3).

3. The Lateral Approach

Start 5 cm proximal to the ankle joint and slightly medial to Chaput's tubercle. Continue distally in a straight line toward the base of the third and fourth metatarsals. Identify and protect the superficial peroneal nerve and proceed through the subcutaneous tissue to expose the superior and inferior extensor retinaculum, and the tendons of the extensor digitorum longus, peroneus tertius, hallucis brevis, and the extensor hallucis longus. After dividing the extensor retinaculum, the tendons of the extensor digitorum longus and peroneus tertius, the deep peroneal nerve, and the dorsalis pedis artery are moved medially. In the distal aspect of the incision, the muscle belly of the extensor digitorum brevis can be seen, and, if greater distal exposure is needed, this can be mobilized. At completion, the exposure should allow visualization of the entire anterior face of the distal tibia, with excellent visualization of the lateral articular surface of the tibia. It will be impossible to apply a medial plate from this incision (Figure 4).

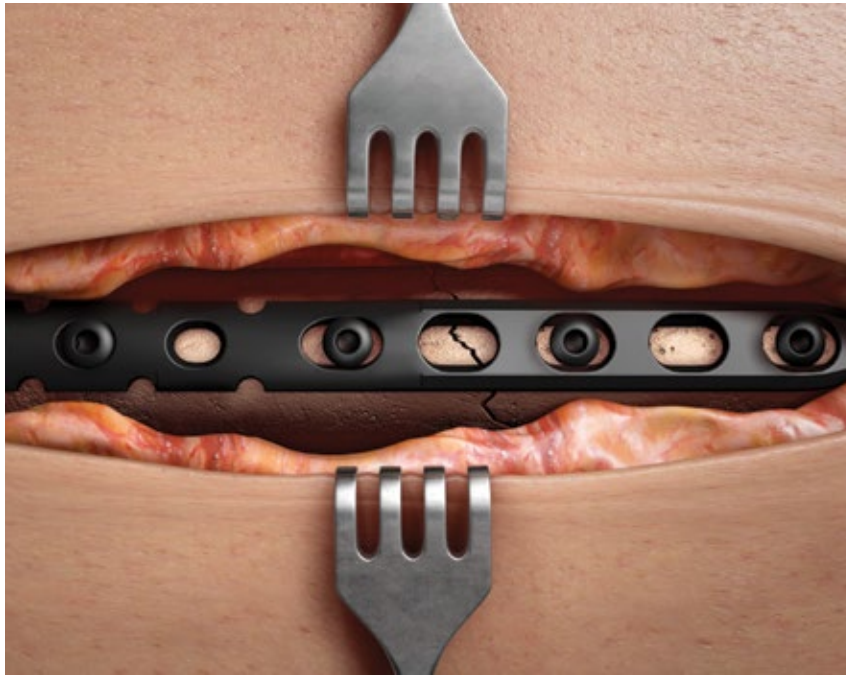

Figure 5

The fibular shaft should be reconstructed initially using standard techniques.

Internal Fixation of Fibula and Malleolus

Fibula and Posterior Malleolar Reconstruction

The fibular shaft and lateral malleolus should be reconstructed initially, depending on the tibial incision planned. If a midline or antero-medial incision is planned, a straight lateral or postero-lateral incision can be used. Standard techniques of fibular plating (Cat. No. 8141-23-0XX) are used (Figure 5). If an anterolateral approach to the tibia is employed, a postero-lateral incision can be used to fix the fibula. Alternately, both tibial and fibular fixation may be

performed through the same anterolateral incision. Furthermore, if plain films and CT scan indicate that the posterior malleolus is “free floating”, then this fragment must be fixed at the time of fibula fixation so that a stable fragment exists to reconstruct the articular surface. If this is not performed, the joint will be mal-reduced at the end of the surgery.

Note: A.L.P.S. Distal Tibia Anterolateral and Medial Plates are not indicated to treat fibular fractures.

A.L.P.S. Distal Tibia Plating System

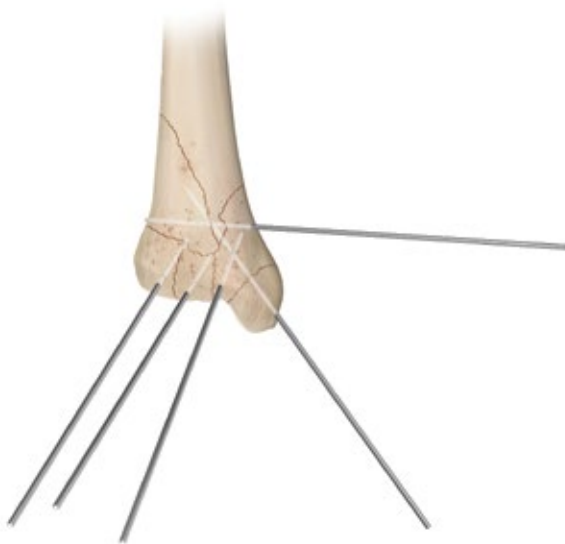

Figure 6

Reconstruct the articular surface by using 1.6 mm K-wires, either with direct reduction of one fragment to another, or by wedging small fragments between larger fragments.

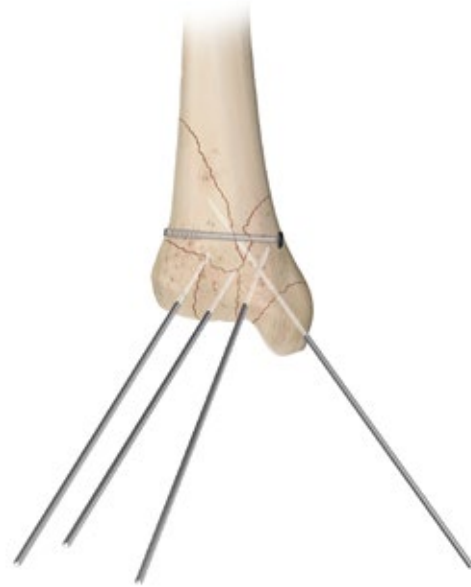

Figure 7

The reconstructed articular block can then be attached to the meta-diaphyseal shaft.

Tibial Reconstruction

When reducing a long bone fracture, axial alignment is the predominant functional requirement. When reducing an articular fracture, both anatomic reconstruction of the joint surface, as well as axial alignment of the shaft is required. While a millimeter step in the joint will result in mild angular mal-alignment in the metaphysis, a millimeter offset in the metaphysis will translate to several millimeters of joint incongruity. For this reason, the articular surface should be approached first.

First externally rotate the medial malleolar fragment. Next, apply ligamentotaxis through distraction using either an external fixator or a femoral distractor. In this way, the comminuted central articular surface can be visualized. Reduce the comminuted fragments by using the constant postero-lateral fragment as the key to the articular reduction. Rebuild the articular surface by using 1.6 mm K-wires (Cat. No. 14425-6), either with direct reduction of one fragment to another, or by wedging small fragments between larger fragments. When the surface has been reconstructed, the medial malleolus is reduced and provisionally pinned (Figure 6).

Once satisfied with the articular reduction, the metaphysis is evaluated. Impaction fractures associated with metaphyseal crush require a cancellous bone graft. Once completed, each critical K-wire is replaced with an isolated 3.5 mm cortical, or 4.0 mm cancellous lag screw. The reconstructed articular block can then be attached to the meta-diaphyseal shaft using either isolated lag screws and a neutralization plate, or a plate alone in compression mode, with or without lag screws through the plate (Figure 7).



Figure 8



Figure 9



Figure 10

Plate Selection

Medial plates cannot be applied using a lateral incision. Similarly lateral plates cannot be applied through a medial incision. While a midline incision allows application of a lateral plate, a medial plate can be applied only with difficulty. Therefore:

- If the fracture is unstable, with lateral comminution, and anterior metaphyseal crush is evident, a lateral approach is chosen, and an anterolateral plate is recommended (Figure 8).
- If the fracture is more comminuted medially, and lateral joint involvement is minimal, a medial incision is used and a medial plate is applied (Figure 9).
- If comminution is both anterior, medial and lateral, then a midline incision may be best, coupled with an antero-lateral plate (Figure 10).

A.L.P.S. Distal Tibia Plating System



Figure 11

Anterolateral Plates are available in 4 lengths and in wide and narrow widths. Wide plates have three F.A.S.T. Tabs, while narrow plates have two F.A.S.T. Tabs.

Plates

Anterolateral Distal Tibial Plate (Cat. No. 8162-0X-0XX).

The Anterolateral Distal Tibial Plate is a low-profile, anatomically contoured plate, designed to fit on the anterolateral aspect of the distal tibia. These thin plates are designed to minimize discomfort and soft tissue irritation around the ankle, while still having the strength needed to achieve rigid fixation of the distal tibial fracture. All plates come with F.A.S.T. Guide inserts for accurate drilling and placement of screws, with locking, lagging, or variable angle screw options available in the same construct (Figure 11).

These plates are pre-contoured and need little, if any, secondary adjustments to their shape. In addition, wide and narrow widths are available to accommodate patient size. Wide plates contain three F.A.S.T. Tabs, while narrow plates contain two F.A.S.T. Tabs.

Contourable F.A.S.T. Tabs with threaded screw holes are present distally to lock small distal articular fragments to the plate. These tabs are adjustable with Plate Tab Benders that fit over the F.A.S.T. Guide inserts for easy and secure control. Contouring can be performed before application, or in situ. Should these tabs not be desired, they are cleanly removed with a few bending cycles, without leaving sharp edges. Alternatively, they may be clipped off with a wire cutter. Screws placed in these rows will create an intersecting scaffold to support the distal articular surface.



Figure 12

Medial Plates are available in 4 lengths.

Medial Tibial Plate (Cat. No. 8162-1X-0XX).

Similar to the Anterolateral Plate, the Medial Plate is a low-profile, anatomically contoured plate, designed to fit the medial aspect of the distal tibia. These thin plates are designed to minimize discomfort and soft tissue irritation around the ankle, while still having the strength needed to achieve rigid fixation of the distal tibial fracture. All plates come with F.A.S.T. Guide inserts for accurate drilling and placement of screws, with locking, lagging, or variable angle screw options available in the same construct (Figure 12).

In addition, these plates are precontoured and need little, if any, secondary adjustments to their shape.

A plate handle can be attached to the distal end of the plate to facilitate insertion and positioning of the plate. The distal tab with a non-locking hole is present to connect distal fragments to the plate. If this tab is not desired, it can remain unfilled. Alternatively, it can be easily removed with a wire cutter.

A.L.P.S. Distal Tibia Plating System



Figure 13
The optimal position of the Anterolateral Plate F.A.S.T. Tabs in relation to the joint is approximately 2 mm from the anterior articular surface.

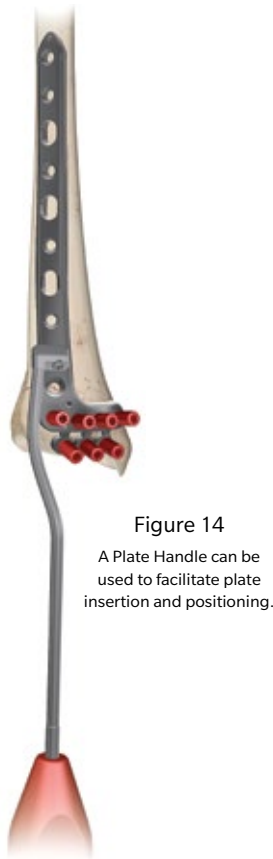

Figure 14
A Plate Handle can be used to facilitate plate insertion and positioning.

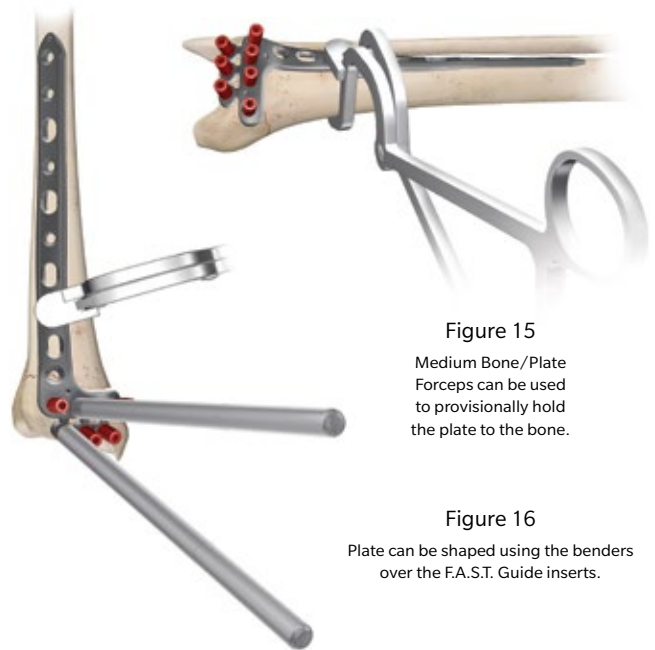

Figure 15
Medium Bone/Plate Forceps can be used to provisionally hold the plate to the bone.

Figure 16
Plate can be shaped using the benders over the F.A.S.T. Guide inserts.

Application of the Plates

The proper plate length is selected by ensuring at least 3-4 screw holes are present proximal to the most proximal extent of the shaft component of the fracture.

Application of the Anterolateral Plate

Slide the shaft of the Anterolateral Plate submuscularly along the lateral border of the tibia, beneath the anterior compartment muscles and neurovascular bundle. The optimal position of the distal plate F.A.S.T. Tabs in relation to the joint is approximately 2 mm from the anterior articular surface (Figure 13). There should be enough clearance to permit full dorsiflexion of the ankle. Use fluoroscopic imaging during plate placement in both the AP and lateral planes to ensure a safe implant position proximally along the lateral tibia.

The Plate Handle can be attached to the plate to facilitate insertion and position the plate in either an open or percutaneous manner (Figure 14). The Plate Handle comes in right (Cat. No. 8163-01-003) and left (Cat. No. 8163-01-004) orientations. The Plate Handle

connects to the distal compression hole on the shaft of the plate. The Plate Handle is secured to the plate by tightening the set screw with the T-15 driver until secured tightly with two fingers. The plate is provisionally clamped to the bone using the Medium Bone/Plate Forceps (Cat. No. 8163-01-006) proximally (Figure 15).

In most cases the pre-contoured plate will fit without the need for further bending. The distal tabs may be contoured as needed using F.A.S.T. Guide inserts and Plate Tab Benders (Cat. No. 8163-01-001).

To contour the F.A.S.T. Tabs, place the benders over a F.A.S.T. Guide insert in each row and exert pressure on the distal bender until the desired contour is achieved (Figure 16).

CAUTION: Bending the distal tabs beyond 25 degrees may result in breakage. Continuous bending will also fatigue the tab and cause it to break.



Figure 17

Slide the Medial Plate under the soft tissue using Plate Handle.

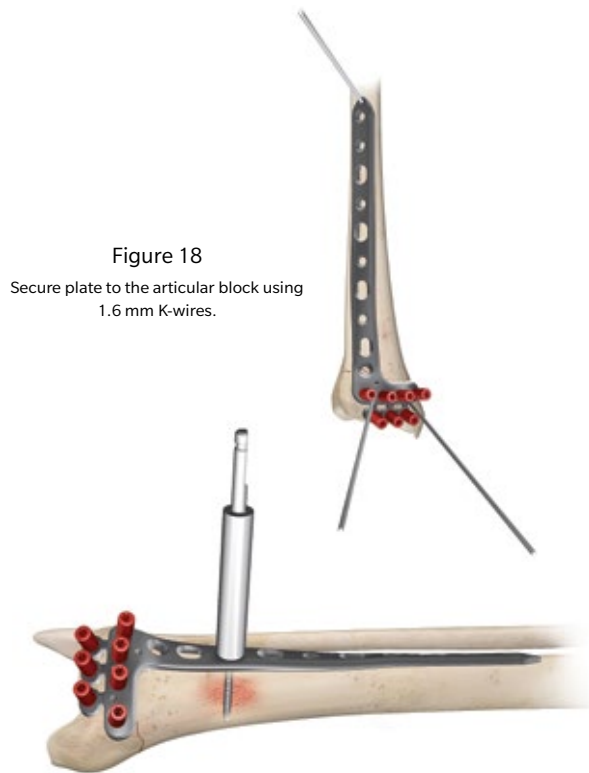

Figure 18

Secure plate to the articular block using 1.6 mm K-wires.

Figure 19

A provisional Fixation Pin may also be used to secure the plate temporarily.

Application of the Medial Plate

Slide the Medial Plate proximally under the soft tissue. The plate conforms to the shape of the distal tibia and the distal end of the plate should conform to the shape of the medial malleolus (Figure 17).

The Plate Handle can be attached to the plate to facilitate insertion and position the plate in either an open or percutaneous manner. The Plate Handle connects to the distal compression hole on the shaft of the plate. The plate handle is secured to the plate by tightening the set screw with the T-15 driver until secured tightly with 2 fingers.

Provisional Fixation

Once the fit of either the Anterolateral Plate or the Medial Plate has been confirmed both visually and fluoroscopically, 1.6 mm K-wires can be placed into the distal K-wire holes to secure the plate to the articular block (Figure 18).

A Provisional Fixation Pin (Cat. No. 8242-99-000/1) may also be used to secure the plate temporarily. The pin has a self-drilling tip and an AO quick connection for power insertion. Advance the pin slowly until the shoulder of the pin contacts the plate and pulls the plate down to the bone. Advancing the pin beyond that point could result in the threads stripping in the bone (Figure 19).

When placing screws in the plate, the plate should be secured from the distal end to the proximal end to prevent the plate from “walking” distally.

If the surgeon desires for the distal end of the plate to sit flush against the bone, then a 4.0 mm non-locked lag screw should be used. Instructions on how to insert a 4.0 mm lag screw can be found in the section titled, “Insertion of a 4.0 mm Non-Locking Screw”.

Note: If a lag screw is used in the metaphyseal part of the plate or distal tabs, then that F.A.S.T. Guide insert needs to be removed prior to drilling.

A.L.P.S. Distal Tibia Plating System



Figure 20

Slide the Measuring Drill Sleeve onto the 2.7 mm Calibrated Drill Bit.

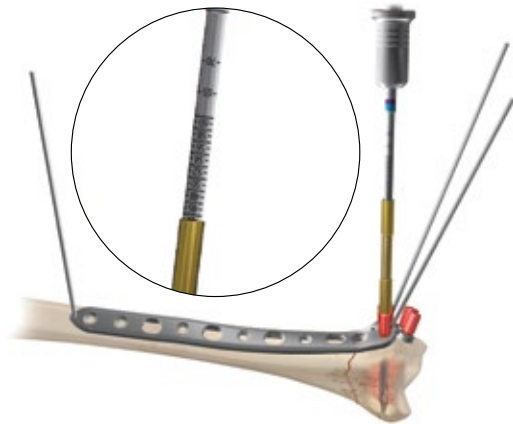

Figure 21

Drill through the F.A.S.T. Guide insert with the 2.7 mm Drill Bit. Slide the Measuring Drill Sleeve to the top end of the F.A.S.T. Guide insert and read the measurement of the Locking Screw length from the proximal end.

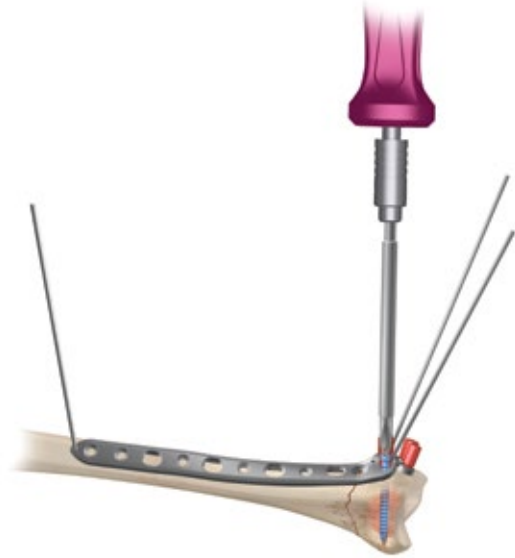

Figure 22

Insert the pre-determined Locking Screw using the T-15 Driver attached to Torque Limiting Driver Handle.

Screw Insertion

Insertion of a 3.5 mm Cortical Locking Screw (Cat. No. 8161-35-0XX) or 4.0 mm Cancellous Locking Screw (Cat. No. 8161-40-0XX) into a Distal Threaded Hole.

Slide the Measuring Drill Sleeve (Cat. No. 8163-01-005) onto the 2.7 mm Calibrated Drill Bit (Cat. No. 2142-27-070) (Figure 20). Drill through the F.A.S.T. Guide insert until the far cortex is reached. Slide the Measuring Drill Sleeve onto the top end of the F.A.S.T. Guide insert and read the measurement of the locking screw length from the proximal end of the Drill Measuring Sleeve (Figure 21). Next, remove the F.A.S.T. Guide insert with the T-15 Driver that is attached to the Ratchet Handle (8261-66-000) and insert the pre-determined locking screw using the T-15 Driver that is attached to the 2.0 Nm Torque-Limiting Screwdriver Handle (Cat. No. 2141-18-001) (Figure 22).

Note: Using a power screwdriver is not recommended for insertion of any locking screws.

If using power, it should be at a slow speed. Perform all final screw tightening by hand with the torque-limiting screwdriver.

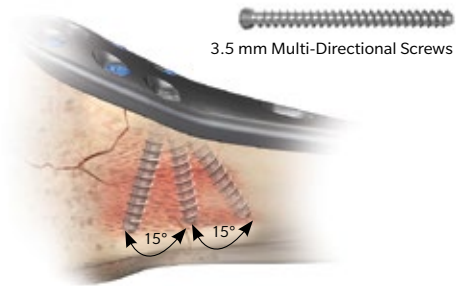

Figure 23

MDS Screw allows up to 15 degrees of angulation from center.



Figure 24

Drill with the 2.7 mm Drill Bit through the 2.0/2.7 mm Drill Guide.



Figure 25

Take a direct reading from the LOCK Line on the Depth Gauge.



Figure 26

Insert the MDS screw using the 2.2 mm Square Driver coupled to the Ratchet Handle.

Insertion of a 3.5 mm Multi-Directional Locking Screw in a Threaded Locking Hole (Cat. No. 8163-35-0XX).

Note: If a 3.5 mm Multi-Directional Screw is used in the metaphyseal part of the plate or distal tabs, then that F.A.S.T. Guide insert needs to be removed prior to drilling. Additionally, note that the Torque Limiting Handle should not be used.

Insert the 2.7 mm end of the 2.0/2.7 mm Drill Guide (Cat. No. 9399-99-435) into the plate hole and angle the drill as needed within an arc of 15 degrees (Figure 23). Drill through both cortices with the 2.7 mm Drill Bit (Figure 24).

Measure the drilled hole with the Small Fragment Depth Gauge (Cat. No. 2142-35-100) by taking a direct reading from the LOCK line (Figure 25) and insert the appropriate length 3.5 mm Multi-Directional Screw with the 2.2 mm Square Driver (Cat. No. 8163-01-000) coupled to the Ratchet Handle (Cat. No. 8261-66-000) (Figure 26).

A.L.P.S. Distal Tibia Plating System

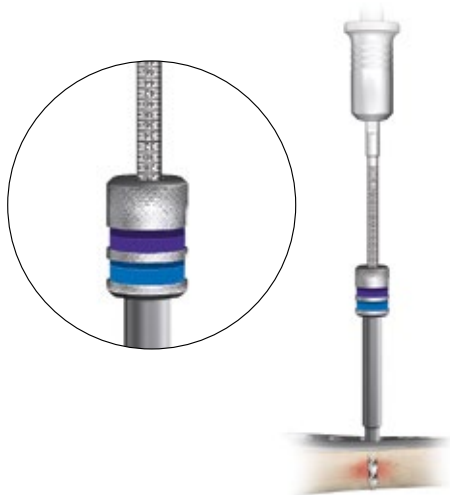

Figure 27

Drill with the 2.7 mm Calibrated Drill Bit reading the depth from the top of the Drill Guide.



Figure 29

Insert the Locking Screw using the T-15 Driver coupled to the Torque-Limiting Screwdriver Handle.

Figure 28

Take reading directly from the LOCK Line on the Small Fragment Depth Gauge.

The proximal end of the plate can now be secured to the bone. This can be achieved through the following options:

Insertion of a Locking Screw (3.5 mm Cortical Cat. No. 8161-35-0XX or 4.0 mm Cancellous Cat. No. 8161-40-0XX) in a Threaded Hole.

Screw the 2.7 mm Locking Drill Guide (Cat. No. 2142-07-027) into a threaded plate hole until fully seated. Drill both cortices with the 2.7 mm Calibrated Drill Bit to the desired depth and read the depth measurement from the calibrated drill bit at the top of the Drill Guide (Figure 27). Remove the 2.7 mm Locking Drill Guide.

Note: If a second method of measurement is desired, measure the drilled hole by taking a direct reading from the LOCK line on the Small Fragment Depth Gauge (Figure 28).

Insert the selected locking screw with the T-15 Driver coupled to the 2.0 Nm Torque-Limiting Screwdriver Handle (Figure 29).

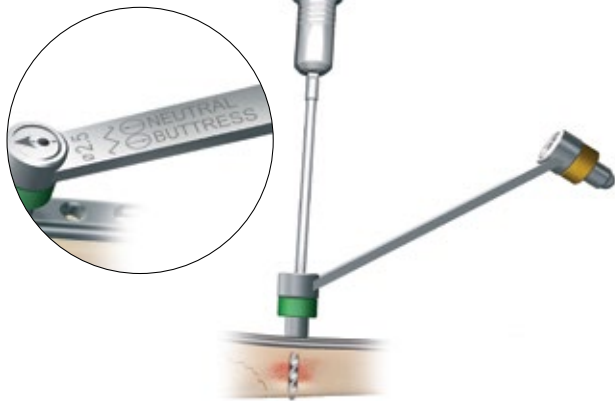

Figure 30

Drill with the 2.5 mm Drill Bit in the neutral position.



Figure 31

Take a depth reading from the NON-L Line.

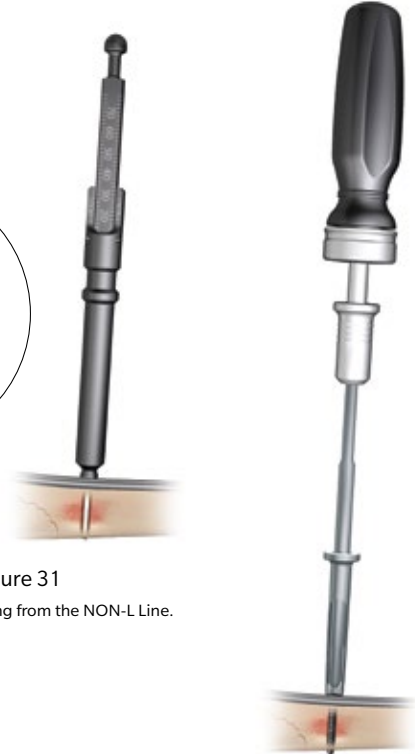

Figure 32

Insert the 3.5 mm Non-Locking Cortical Screw using the 2.5 mm Hex Driver.

Neutral insertion of a 3.5mm Non-Locking Cortical Screw (Cat. No. 8150-37-0XX) in a Compression Slot.

Apply the neutral (green) end of the 2.5 mm ACP Drill Guide (Cat. No. 8241-68-000) onto a compression slot in the plate, with the arrow pointed toward the fracture line (Figure 30). Drill through both cortices with the 2.5 mm Drill Bit (Cat. No. 8290-29-070).

Measure the drilled hole with the Small Fragment Depth Gauge (Figure 31) by taking a direct reading from the NON-L line.

Insert the 3.5 mm Non-Locking Cortical Screw with the Screw Holder Sleeve (Cat. No. 8241-66-000) over the 2.5 mm Hex Driver (Cat. No. 8241-57-071) in the Ratchet Handle (Cat. No. 8261-66-000) (Figure 32).

Caution: The arrow on the neutral (green) end of the 2.5 mm ACP Drill Guide must point toward the fracture site to ensure neutral screw placement.

A.L.P.S. Distal Tibia Plating System

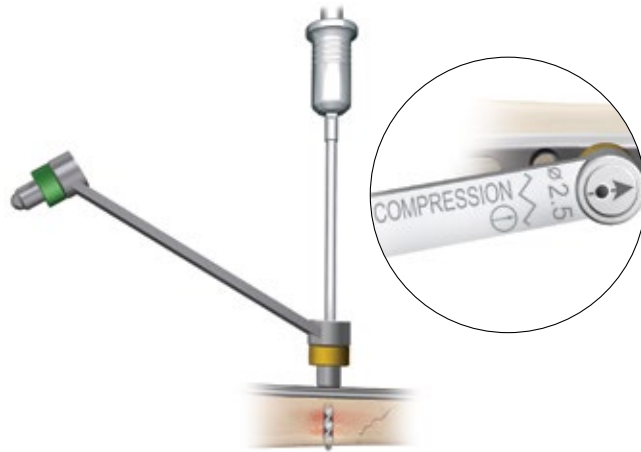

Figure 33

Drill with the 2.5 mm Drill Bit in the eccentric position.

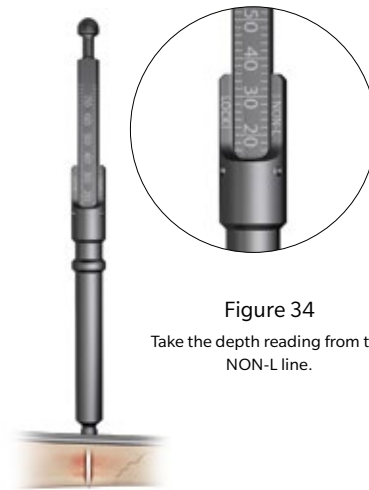

Figure 34

Take the depth reading from the NON-L line.



Figure 35

Insert the 3.5 mm Non-Locking Cortical Screw using the 2.5 mm Hex Driver.

Dynamic compression using a 3.5 mm Non-Locking Cortical Screw in a Compression Slot.

Apply the compression (gold) end of the 2.5 mm ACP Drill Guide onto the compression slot with the arrow pointed toward the fracture line (Figure 33). Drill through both cortices with the 2.5 mm Drill Bit.

Measure the drilled hole with the Small Fragment Depth Gauge (Figure 33) by taking a direct reading from the NON-Line (Figure 34).

Insert the appropriate length 3.5 mm Non-Locking Cortical Screw with the Screw Holder Sleeve over the 2.5 mm Hex Driver coupled to the Ratchet Handle (Figure 35).



Figure 36

Drill with the 2.5 mm Drill Bit through the 2.5/3.5 mm Drill Guide.



Figure 37

Take a depth reading from the NON-L Line.

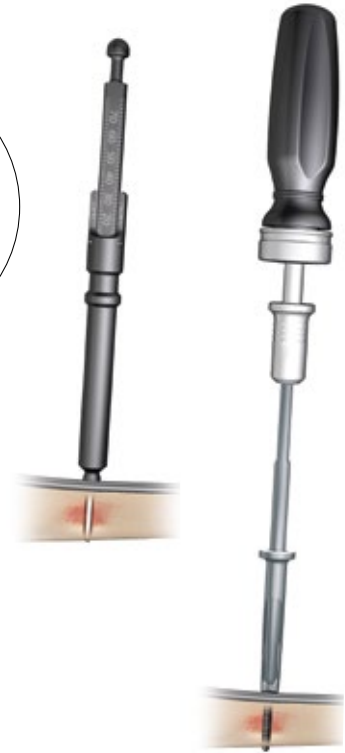

Figure 38

Insert the 3.5 mm Non-Locking Cortical Screw using the 2.5 mm Hex Driver.

Insertion of a 3.5 mm Non-Locking Cortical Screw in a Threaded Hole.

Insert the 2.5 mm end of the 2.5/3.5 mm Drill Guide (Cat. No. 8241-96-000) into the threaded hole and drill through both cortices with the 2.5 mm Drill Bit (Figure 36).

Measure the drilled hole with the Small Fragment Depth Gauge (Figure 37) by taking a direct reading from the NON-L line.

Insert the appropriate length 3.5 mm Non-Locking Cortical Screw with the Screw Holder Sleeve over the 2.5 mm Hex Driver coupled to the Ratchet Handle (Figure 38).

A.L.P.S. Distal Tibia Plating System



Figure 39

Drill using 2.9 mm Drill Bit through 2.9/4.0 mm Drill Guide.



Figure 40

Take a depth reading from the NON-L Line.

Figure 41

Insert the 4.0 mm Non-Locking Screw using the 2.5 mm Hex Driver.

4.0 mm Non-Locking Screw (Cancellous Full Thread Cat. No. 8153-41-0XX or Cancellous Lag Cat. No. 8155-40-0XX) into any Plate Hole.

Insert the 2.9 mm end of the 2.9/4.0 mm Drill Guide (Cat. No. 2141-29-400) into a plate hole and drill through both cortices with the 2.9 mm Drill Bit (Cat. No. 8290-31-070) (Figure 39).

Measure the drilled hole with the Small Fragment Depth Gauge by taking a direct reading from the NON-L line (Figure 40).

Insert the appropriate length 4.0 mm cancellous screw with the screw holder sleeve over the 2.5 mm Hex Driver coupled to the Ratchet Handle (Figure 41).

Instruments and Implants

Ordering Information

Instruments

Order Code	Description
8241-68-000	2.5 mm ACP Drill Guide
8241-76-000	Bending Sticks
8261-66-000	Cannulated Ratchet Handle
2142-35-100	Depth Gauge
8163-01-007	Distal Tibia Handle Set Screw
8163-01-003	Distal Tibia Plate Handle, Right
8163-01-004	Distal Tibia Plate Handle, Left
9399-99-435	2.0 / 2.7 mm Drill Guide
8241-96-000	2.5 / 3.5 mm Drill Guide
2141-29-400	2.9 / 4.0 mm Drill Guide
2312-18-015	1.6 mm F.A.S.T. Guide Adapter
8241-57-071	2.5 mm Hex Driver
2142-07-027	2.7 mm Locking Drill Guide
8163-01-006	Medium Plate / Bone Forceps
8163-01-001	Plate Tab Benders
8162-99-001	20.0 mm Provisional Fixation Pin
8162-99-006	40.0 mm Provisional Fixation Pin
8241-66-000	Screw Holder Sleeve
8163-01-000	2.2 mm Square Driver
2142-15-070	T-15 Driver
2141-18-001	20Nm Torque-Limiting Screwdriver
8163-05-006	Left Distal Tibial Anterolateral Wide Plate Template, 6 Hole
8163-05-009	Left Distal Tibial Anterolateral Wide Plate Template, 9 Hole
8163-05-015	Left Distal Tibial Anterolateral Wide Plate Template, 12/15 Hole
8163-05-106	Right Distal Tibial Anterolateral Wide Plate Template, 6 Hole
8163-05-109	Right Distal Tibial Anterolateral Wide Plate Template, 9 Hole
8163-05-115	Right Distal Tibial Anterolateral Wide Plate Template, 12/15 Hole
8163-05-206	Left Distal Tibial Anterolateral Narrow Plate Template, 6 Hole
8163-05-209	Left Distal Tibial Anterolateral Narrow Plate Template, 9 Hole
8163-05-215	Left Distal Tibial Anterolateral Narrow Plate Template, 12/15 Hole
8163-05-306	Right Distal Tibial Anterolateral Narrow Plate Template, 6 Hole
8163-05-309	Right Distal Tibial Anterolateral Narrow Plate Template, 9 Hole
8163-05-315	Right Distal Tibial Anterolateral Narrow Plate Template, 12/15 Hole
8163-06-006	Left Distal Tibia Medial Plate Template, 6 Hole
8163-06-009	Left Distal Tibia Medial Plate Template, 9 Hole
8163-06-015	Left Distal Tibia Medial Plate Template, 12/15 Hole
8163-06-106	Right Distal Tibia Medial Plate Template, 6 Hole
8163-06-109	Right Distal Tibia Medial Plate Template, 9 Hole
8163-06-115	Right Distal Tibia Medial Plate Template, 12/15 Hole
8163-07-315	Small Metal Plate Template, 3/5 Hole
8163-07-305	Large Metal Plate Template, 3/5 Hole
8163-07-403	Medial Pilon Plate Template, 3 Hole
8163-07-407	Medial Pilon Plate Template, 5 Hole

Instruments and Implants

Ordering Information

Instrument Cases

Order Code	Description
8299-53-500	A.L.P.S. Tibia and Fibula Sterile Case
8299-53-000	A.L.P.S. Tibia Non-Sterile Case

Disposables

Order Code	Description
8563-01-005	Drill Sleeve
2142-27-160	2.7 Calibrated Drill Bit
8295-16-150	1.6 mm K-wire
8290-29-170	2.5 mm Drill Bit
8290-31-170	2.9 mm Drill Bit

Implants

Non-Sterile	Sterile	Description
8162-00-006	8562-00-006	Right Distal Tibial Anterolateral Locking Wide Plate, 6 Hole
8162-00-009	8562-00-009	Right Distal Tibial Anterolateral Locking Wide Plate, 9 Hole
8162-00-012	8562-00-012	Right Distal Tibial Anterolateral Locking Wide Plate, 12 Hole
8162-00-015	8562-00-015	Right Distal Tibial Anterolateral Locking Wide Plate, 15 Hole
8162-01-006	8562-01-006	Left Distal Tibial Anterolateral Locking Wide Plate, 6 Hole
8162-01-009	8562-01-009	Left Distal Tibial Anterolateral Locking Wide Plate, 9 Hole
8162-01-012	8562-01-012	Left Distal Tibial Anterolateral Locking Wide Plate, 12 Hole
8162-01-015	8562-01-015	Left Distal Tibial Anterolateral Locking Wide Plate, 15 Hole
8162-02-006	8562-02-006	Right Distal Tibial Anterolateral Locking Narrow Plate, 6 Hole
8162-02-009	8562-02-009	Right Distal Tibial Anterolateral Locking Narrow Plate, 9 Hole
8162-02-012	8562-02-012	Right Distal Tibial Anterolateral Locking Narrow Plate, 12 Hole
8162-02-015	8562-02-015	Right Distal Tibial Anterolateral Locking Narrow Plate, 15 Hole
8162-03-006	8562-03-006	Left Distal Tibial Anterolateral Locking Narrow Plate, 6 Hole
8162-03-009	8562-03-009	Left Distal Tibial Anterolateral Locking Narrow Plate, 9 Hole
8162-03-012	8562-03-012	Left Distal Tibial Anterolateral Locking Narrow Plate, 12 Hole
8162-03-015	8562-03-015	Left Distal Tibial Anterolateral Locking Narrow Plate, 15 Hole
8162-10-006	8562-10-006	Right Distal Tibia Medial Locking Plate, 6 Hole
8162-10-009	8562-10-009	Right Distal Tibia Medial Locking Plate, 9 Hole
8162-10-012	8562-10-012	Right Distal Tibia Medial Locking Plate, 12 Hole
8162-10-015	8562-10-015	Right Distal Tibia Medial Locking Plate, 15 Hole
8162-11-006	8562-11-006	Left Distal Tibia Medial Locking Plate, 6 Hole
8162-11-009	8562-11-009	Left Distal Tibia Medial Locking Plate, 9 Hole
8162-11-012	8562-11-012	Left Distal Tibia Medial Locking Plate, 12 Hole
8162-11-015	8562-11-015	Left Distal Tibia Medial Locking Plate, 15 Hole



Screws

Ordering Information

Non-Locking Cortical Screw



Non-Sterile	Sterile	Description
8150-37-010	8550-37-010	3.5 x 10.0 mm Non-Locking Cortical Screw
8150-37-012	8550-37-012	3.5 x 12.0 mm Non-Locking Cortical Screw
8150-37-014	8550-37-014	3.5 x 14.0 mm Non-Locking Cortical Screw
8150-37-016	8550-37-016	3.5 x 16.0 mm Non-Locking Cortical Screw
8150-37-018	8550-37-018	3.5 x 18.0 mm Non-Locking Cortical Screw
8150-37-020	8550-37-020	3.5 x 20.0 mm Non-Locking Cortical Screw
8150-37-022	8550-37-022	3.5 x 22.0 mm Non-Locking Cortical Screw
8150-37-024	8550-37-024	3.5 x 24.0 mm Non-Locking Cortical Screw
8150-37-026	8550-37-026	3.5 x 26.0 mm Non-Locking Cortical Screw
8150-37-028	8550-37-028	3.5 x 28.0 mm Non-Locking Cortical Screw
8150-37-030	8550-37-030	3.5 x 30.0 mm Non-Locking Cortical Screw
8150-37-032	8550-37-032	3.5 x 32.0 mm Non-Locking Cortical Screw
8150-37-034	8550-37-034	3.5 x 34.0 mm Non-Locking Cortical Screw
8150-37-036	8550-37-036	3.5 x 36.0 mm Non-Locking Cortical Screw
8150-37-038	8550-37-038	3.5 x 38.0 mm Non-Locking Cortical Screw
8150-37-040	8550-37-040	3.5 x 40.0 mm Non-Locking Cortical Screw
8150-37-042	8550-37-042	3.5 x 42.0 mm Non-Locking Cortical Screw
8150-37-044	8550-37-044	3.5 x 44.0 mm Non-Locking Cortical Screw
8150-37-046	8550-37-046	3.5 x 46.0 mm Non-Locking Cortical Screw
8150-37-048	8550-37-048	3.5 x 48.0 mm Non-Locking Cortical Screw
8150-37-050	8550-37-050	3.5 x 50.0 mm Non-Locking Cortical Screw
8150-37-055	8550-37-055	3.5 x 55.0 mm Non-Locking Cortical Screw
8150-37-060	8550-37-060	3.5 x 60.0 mm Non-Locking Cortical Screw
8150-37-065	8550-37-065	3.5 x 65.0 mm Non-Locking Cortical Screw
8150-37-070	8550-37-070	3.5 x 70.0 mm Non-Locking Cortical Screw

Screws

Ordering Information

Low-Profile Cortical Screw



Non-Sterile	Sterile	Description
1312-18-010	8512-35-010	3.5 x 10.0 mm Low-Profile Cortical Screw
1312-18-012	8512-35-012	3.5 x 12.0 mm Low-Profile Cortical Screw
1312-18-014	8512-35-014	3.5 x 14.0 mm Low-Profile Cortical Screw
1312-18-016	8512-35-016	3.5 x 16.0 mm Low-Profile Cortical Screw
1312-18-018	8512-35-018	3.5 x 18.0 mm Low-Profile Cortical Screw
1312-18-020	8512-35-020	3.5 x 20.0 mm Low-Profile Cortical Screw
1312-18-022	8512-35-022	3.5 x 22.0 mm Low-Profile Cortical Screw
1312-18-024	8512-35-024	3.5 x 24.0 mm Low-Profile Cortical Screw
1312-18-026	8512-35-026	3.5 x 26.0 mm Low-Profile Cortical Screw
1312-18-028	8512-35-028	3.5 x 28.0 mm Low-Profile Cortical Screw
1312-18-030	8512-35-030	3.5 x 30.0 mm Low-Profile Cortical Screw
1312-18-032	8512-35-032	3.5 x 32.0 mm Low-Profile Cortical Screw
1312-18-034	8512-35-034	3.5 x 34.0 mm Low-Profile Cortical Screw
1312-18-036	8512-35-036	3.5 x 36.0 mm Low-Profile Cortical Screw
1312-18-038	8512-35-038	3.5 x 38.0 mm Low-Profile Cortical Screw
1312-18-040	8512-35-040	3.5 x 40.0 mm Low-Profile Cortical Screw
1312-18-042	8512-35-042	3.5 x 42.0 mm Low-Profile Cortical Screw
1312-18-044	8512-35-044	3.5 x 44.0 mm Low-Profile Cortical Screw
1312-18-046	8512-35-046	3.5 x 46.0 mm Low-Profile Cortical Screw
1312-18-048	8512-35-048	3.5 x 48.0 mm Low-Profile Cortical Screw
1312-18-050	8512-35-050	3.5 x 50.0 mm Low-Profile Cortical Screw

Screws

Ordering Information

Locking Cortical Screw



Non-Sterile	Sterile	Description
8161-35-010	8561-35-010	3.5 x 10.0 mm Locking Cortical Screw
8161-35-012	8561-35-012	3.5 x 12.0 mm Locking Cortical Screw
8161-35-014	8561-35-014	3.5 x 14.0 mm Locking Cortical Screw
8161-35-016	8561-35-016	3.5 x 16.0 mm Locking Cortical Screw
8161-35-018	8561-35-018	3.5 x 18.0 mm Locking Cortical Screw
8161-35-020	8561-35-020	3.5 x 20.0 mm Locking Cortical Screw
8161-35-022	8561-35-022	3.5 x 22.0 mm Locking Cortical Screw
8161-35-024	8561-35-024	3.5 x 24.0 mm Locking Cortical Screw
8161-35-026	8561-35-026	3.5 x 26.0 mm Locking Cortical Screw
8161-35-028	8561-35-028	3.5 x 28.0 mm Locking Cortical Screw
8161-35-030	8561-35-030	3.5 x 30.0 mm Locking Cortical Screw
8161-35-032	8561-35-032	3.5 x 32.0 mm Locking Cortical Screw
8161-35-034	8561-35-034	3.5 x 34.0 mm Locking Cortical Screw
8161-35-036	8561-35-036	3.5 x 36.0 mm Locking Cortical Screw
8161-35-038	8561-35-038	3.5 x 38.0 mm Locking Cortical Screw
8161-35-040	8561-35-040	3.5 x 40.0 mm Locking Cortical Screw
8161-35-042	8561-35-042	3.5 x 42.0 mm Locking Cortical Screw
8161-35-044	8561-35-044	3.5 x 44.0 mm Locking Cortical Screw
8161-35-046	8561-35-046	3.5 x 46.0 mm Locking Cortical Screw
8161-35-048	8561-35-048	3.5 x 48.0 mm Locking Cortical Screw
8161-35-050	8561-35-050	3.5 x 50.0 mm Locking Cortical Screw
8161-35-052	8561-35-052	3.5 x 52.0 mm Locking Cortical Screw
8161-35-054	8561-35-054	3.5 x 54.0 mm Locking Cortical Screw
8161-35-056	8561-35-056	3.5 x 56.0 mm Locking Cortical Screw
8161-35-058	8561-35-058	3.5 x 58.0 mm Locking Cortical Screw
8161-35-060	8561-35-060	3.5 x 60.0 mm Locking Cortical Screw
8161-35-065	8561-35-065	3.5 x 65.0 mm Locking Cortical Screw
8161-35-070	8561-35-070	3.5 x 70.0 mm Locking Cortical Screw

Screws

Ordering Information

Non-Locking Cancellous Screw



Non-Sterile	Sterile	Description
8153-41-010	8553-40-010	4.0 x 10.0 Non-Locking Cancellous Screw
8153-41-012	8553-40-012	4.0 x 12.0 Non-Locking Cancellous Screw
8153-41-014	8553-40-014	4.0 x 14.0 Non-Locking Cancellous Screw
8153-41-016	8553-40-016	4.0 x 16.0 Non-Locking Cancellous Screw
8153-41-018	8553-40-018	4.0 x 18.0 Non-Locking Cancellous Screw
8153-41-020	8553-40-020	4.0 x 20.0 Non-Locking Cancellous Screw
8153-41-022	8553-40-022	4.0 x 22.0 Non-Locking Cancellous Screw
8153-41-024	8553-40-024	4.0 x 24.0 Non-Locking Cancellous Screw
8153-41-026	8553-40-026	4.0 x 26.0 Non-Locking Cancellous Screw
8153-41-028	8553-40-028	4.0 x 28.0 Non-Locking Cancellous Screw
8153-41-030	8553-40-030	4.0 x 30.0 Non-Locking Cancellous Screw
8153-41-032	8553-40-032	4.0 x 32.0 Non-Locking Cancellous Screw
8153-41-034	8553-40-034	4.0 x 34.0 Non-Locking Cancellous Screw
8153-41-036	8553-40-036	4.0 x 36.0 Non-Locking Cancellous Screw
8153-41-038	8553-40-038	4.0 x 38.0 Non-Locking Cancellous Screw
8153-41-040	8553-40-040	4.0 x 40.0 Non-Locking Cancellous Screw
8153-41-042	8553-40-042	4.0 x 42.0 Non-Locking Cancellous Screw
8153-41-044	8553-40-044	4.0 x 44.0 Non-Locking Cancellous Screw
8153-41-046	8553-40-046	4.0 x 46.0 Non-Locking Cancellous Screw
8153-41-048	8553-40-048	4.0 x 48.0 Non-Locking Cancellous Screw
8153-41-050	8553-40-050	4.0 x 50.0 Non-Locking Cancellous Screw
8153-41-055	8553-40-055	4.0 x 55.0 Non-Locking Cancellous Screw
8153-41-060	8553-40-060	4.0 x 60.0 Non-Locking Cancellous Screw
8153-41-065	8553-40-065	4.0 x 65.0 Non-Locking Cancellous Screw
8153-41-070	8553-40-070	4.0 x 70.0 Non-Locking Cancellous Screw

Screws

Ordering Information

Locking Cancellous Screw



Non-Sterile	Sterile	Description
8161-40-010	8561-40-010	4.0 x 10.0 mm Locking Cancellous Screw
8161-40-012	8561-40-012	4.0 x 12.0 mm Locking Cancellous Screw
8161-40-014	8561-40-014	4.0 x 14.0 mm Locking Cancellous Screw
8161-40-016	8561-40-016	4.0 x 16.0 mm Locking Cancellous Screw
8161-40-018	8561-40-018	4.0 x 18.0 mm Locking Cancellous Screw
8161-40-020	8561-40-020	4.0 x 20.0 mm Locking Cancellous Screw
8161-40-022	8561-40-022	4.0 x 22.0 mm Locking Cancellous Screw
8161-40-024	8561-40-024	4.0 x 24.0 mm Locking Cancellous Screw
8161-40-026	8561-40-026	4.0 x 26.0 mm Locking Cancellous Screw
8161-40-028	8561-40-028	4.0 x 28.0 mm Locking Cancellous Screw
8161-40-030	8561-40-030	4.0 x 30.0 mm Locking Cancellous Screw
8161-40-032	8561-40-032	4.0 x 32.0 mm Locking Cancellous Screw
8161-40-034	8561-40-034	4.0 x 34.0 mm Locking Cancellous Screw
8161-40-036	8561-40-036	4.0 x 36.0 mm Locking Cancellous Screw
8161-40-038	8561-40-038	4.0 x 38.0 mm Locking Cancellous Screw
8161-40-040	8561-40-040	4.0 x 40.0 mm Locking Cancellous Screw
8161-40-042	8561-40-042	4.0 x 42.0 mm Locking Cancellous Screw
8161-40-044	8561-40-044	4.0 x 44.0 mm Locking Cancellous Screw
8161-40-046	8561-40-046	4.0 x 46.0 mm Locking Cancellous Screw
8161-40-048	8561-40-048	4.0 x 48.0 mm Locking Cancellous Screw
8161-40-050	8561-40-050	4.0 x 50.0 mm Locking Cancellous Screw
8161-40-055	8561-40-055	4.0 x 55.0 mm Locking Cancellous Screw
8161-40-060	8561-40-060	4.0 x 60.0 mm Locking Cancellous Screw
8161-40-065	8561-40-065	4.0 x 65.0 mm Locking Cancellous Screw
8161-40-070	8561-40-070	4.0 x 70.0 mm Locking Cancellous Screw

Screws

Ordering Information

Cancellous Lag Screw



Non-Sterile	Sterile	Description
8155-40-014	8555-40-014	4.0 x 14.0 mm Cancellous Lag Screw
8155-40-016	8555-40-016	4.0 x 16.0 mm Cancellous Lag Screw
8155-40-018	8555-40-018	4.0 x 18.0 mm Cancellous Lag Screw
8155-40-020	8555-40-020	4.0 x 20.0 mm Cancellous Lag Screw
8155-40-022	8555-40-022	4.0 x 22.0 mm Cancellous Lag Screw
8155-40-024	8555-40-024	4.0 x 24.0 mm Cancellous Lag Screw
8155-40-026	8555-40-026	4.0 x 26.0 mm Cancellous Lag Screw
8155-40-028	8555-40-028	4.0 x 28.0 mm Cancellous Lag Screw
8155-40-030	8555-40-030	4.0 x 30.0 mm Cancellous Lag Screw
8155-40-035	8555-40-035	4.0 x 35.0 mm Cancellous Lag Screw
8155-40-040	8555-40-040	4.0 x 40.0 mm Cancellous Lag Screw
8155-40-045	8555-40-045	4.0 x 45.0 mm Cancellous Lag Screw
8155-40-050	8555-40-050	4.0 x 50.0 mm Cancellous Lag Screw
8155-40-055	8555-40-055	4.0 x 55.0 mm Cancellous Lag Screw
8155-40-060	8555-40-060	4.0 x 60.0 mm Cancellous Lag Screw
8155-40-065	8555-40-065	4.0 x 65.0 mm Cancellous Lag Screw
8155-40-070	8555-40-070	4.0 x 70.0 mm Cancellous Lag Screw
8155-40-075	8555-40-075	4.0 x 75.0 mm Cancellous Lag Screw
8155-40-080	8555-40-080	4.0 x 80.0 mm Cancellous Lag Screw
8155-40-085	8555-40-085	4.0 x 85.0 mm Cancellous Lag Screw
8155-40-090	8555-40-090	4.0 x 90.0 mm Cancellous Lag Screw
8155-40-095	8555-40-095	4.0 x 95.0 mm Cancellous Lag Screw
8155-40-100	8555-40-100	4.0 x 100.0 mm Cancellous Lag Screw

Screws

Ordering Information

Cannulated Cancellous Lag Screw

Non-Sterile	Sterile	Description
1437610	8514-40-010	4.0 x 10.0 mm Cannulated Cancellous Lag Screw
1437612	8514-40-012	4.0 x 12.0 mm Cannulated Cancellous Lag Screw
1437614	8514-40-014	4.0 x 14.0 mm Cannulated Cancellous Lag Screw
1437616	8514-40-016	4.0 x 16.0 mm Cannulated Cancellous Lag Screw
1437618	8514-40-018	4.0 x 18.0 mm Cannulated Cancellous Lag Screw
1437620	8514-40-020	4.0 x 20.0 mm Cannulated Cancellous Lag Screw
1437622	8514-40-022	4.0 x 22.0 mm Cannulated Cancellous Lag Screw
1437624	8514-40-024	4.0 x 24.0 mm Cannulated Cancellous Lag Screw
1437626	8514-40-026	4.0 x 26.0 mm Cannulated Cancellous Lag Screw
1437628	8514-40-028	4.0 x 28.0 mm Cannulated Cancellous Lag Screw
1437630	8514-40-030	4.0 x 30.0 mm Cannulated Cancellous Lag Screw
1437632	8514-40-032	4.0 x 32.0 mm Cannulated Cancellous Lag Screw
1437634	8514-40-034	4.0 x 34.0 mm Cannulated Cancellous Lag Screw
1437636	8514-40-036	4.0 x 36.0 mm Cannulated Cancellous Lag Screw
1437638	8514-40-038	4.0 x 38.0 mm Cannulated Cancellous Lag Screw
1437640	8514-40-040	4.0 x 40.0 mm Cannulated Cancellous Lag Screw
1437642	8514-40-042	4.0 x 42.0 mm Cannulated Cancellous Lag Screw
1437644	8514-40-044	4.0 x 44.0 mm Cannulated Cancellous Lag Screw
1437646	8514-40-046	4.0 x 46.0 mm Cannulated Cancellous Lag Screw
1437648	8514-40-048	4.0 x 48.0 mm Cannulated Cancellous Lag Screw
1437650	8514-40-050	4.0 x 50.0 mm Cannulated Cancellous Lag Screw
1437655	8514-40-055	4.0 x 55.0 mm Cannulated Cancellous Lag Screw
1437660	8514-40-060	4.0 x 60.0 mm Cannulated Cancellous Lag Screw
1437665	8514-40-065	4.0 x 65.0 mm Cannulated Cancellous Lag Screw
1437670	8514-40-070	4.0 x 70.0 mm Cannulated Cancellous Lag Screw

Screws

Ordering Information

Multi-Directional Locking Screw



Non-Sterile	Sterile	Description
8163-35-010	8563-35-010	3.5 x 10.0 mm Multi-Directional Locking Screw
8163-35-012	8563-35-012	3.5 x 12.0 mm Multi-Directional Locking Screw
8163-35-014	8563-35-014	3.5 x 14.0 mm Multi-Directional Locking Screw
8163-35-016	8563-35-016	3.5 x 16.0 mm Multi-Directional Locking Screw
8163-35-018	8563-35-018	3.5 x 18.0 mm Multi-Directional Locking Screw
8163-35-020	8563-35-020	3.5 x 20.0 mm Multi-Directional Locking Screw
8163-35-022	8563-35-022	3.5 x 22.0 mm Multi-Directional Locking Screw
8163-35-024	8563-35-024	3.5 x 24.0 mm Multi-Directional Locking Screw
8163-35-026	8563-35-026	3.5 x 26.0 mm Multi-Directional Locking Screw
8163-35-028	8563-35-028	3.5 x 28.0 mm Multi-Directional Locking Screw
8163-35-030	8563-35-030	3.5 x 30.0 mm Multi-Directional Locking Screw
8163-35-032	8563-35-032	3.5 x 32.0 mm Multi-Directional Locking Screw
8163-35-034	8563-35-034	3.5 x 34.0 mm Multi-Directional Locking Screw
8163-35-036	8563-35-036	3.5 x 36.0 mm Multi-Directional Locking Screw
8163-35-038	8563-35-038	3.5 x 38.0 mm Multi-Directional Locking Screw
8163-35-040	8563-35-040	3.5 x 40.0 mm Multi-Directional Locking Screw
8163-35-042	8563-35-042	3.5 x 42.0 mm Multi-Directional Locking Screw
8163-35-044	8563-35-044	3.5 x 44.0 mm Multi-Directional Locking Screw
8163-35-046	8563-35-046	3.5 x 46.0 mm Multi-Directional Locking Screw
8163-35-048	8563-35-048	3.5 x 48.0 mm Multi-Directional Locking Screw
8163-35-050	8563-35-050	3.5 x 50.0 mm Multi-Directional Locking Screw
8163-35-052	8563-35-052	3.5 x 52.0 mm Multi-Directional Locking Screw
8163-35-054	8563-35-054	3.5 x 54.0 mm Multi-Directional Locking Screw
8163-35-056	8563-35-056	3.5 x 56.0 mm Multi-Directional Locking Screw
8163-35-058	8563-35-058	3.5 x 58.0 mm Multi-Directional Locking Screw
8163-35-060	8563-35-060	3.5 x 60.0 mm Multi-Directional Locking Screw

Indications for Use:**The Medial Locking Plate is indicated for:**

- Pilon Fractures: distal tibial intra-articular fractures.
- High medial malleolar fractures.
- Low boot type rotational distal extra-articular shaft fractures.

while the Anterolateral Locking Plate is indicated for:

- Distal intra-articular tibia fractures.
- Proximal tibia fractures.
- Proximal and distal humerus fractures.

Contraindications:

Contraindications (orthopaedic screws, intramedullary nails, plates, compression hip screws, pins and wires):

- Cases where there is an active infection.
- Conditions which tend to retard healing such as, blood supply limitations, previous infections, etc.
- Insufficient quantity or quality of bone to permit stabilization of the fracture.
- Conditions that restrict the patient's ability or willingness to follow postoperative instructions during the healing process.
- Foreign body sensitivity – where material sensitivity is suspected, appropriate tests should be made and sensitivity ruled out prior to implantations.
- Cases where the implant(s) would cross open epiphyseal plates in skeletally immature patients.

Additional Contraindications – Orthopaedic Screws and Plates Only:

Cases with malignant primary or metastatic tumors which preclude adequate bone support or screw fixations, unless supplemental fixation or stabilization methods are utilized.

This material is intended for healthcare professionals and the Zimmer Biomet sales force. Distribution to any other recipient is prohibited. For indications, contraindications, warnings, precautions, potential adverse effects and patient counseling information, see the package insert or contact your local representative; visit www.zimmerbiomet.com for additional product information. All content herein is protected by copyright, trademarks and other intellectual property rights, as applicable, owned by or licensed to Zimmer Biomet or its affiliates unless otherwise indicated, and must not be redistributed, duplicated or disclosed, in whole or in part, without the express written consent of Zimmer Biomet.

Check for country product clearances and reference product specific instructions for use. Zimmer Biomet does not practice medicine. This technique was developed in conjunction with health care professional. This document is intended for surgeons and is not intended for laypersons. Each surgeon should exercise his or her own independent judgment in the diagnosis and treatment of an individual patient, and this information does not purport to replace the comprehensive training surgeons have received. As with all surgical procedures, the technique used in each case will depend on the surgeon's medical judgment as the best treatment for each patient. Results will vary based on health, weight, activity and other variables. Not all patients are candidates for this product and/or procedure. Caution: Federal (USA) law restricts this device to sale by or on the order of a surgeon. Rx only.

CE Mark on the surgical technique is not valid unless there is a CE Mark on the product (description) label.

©2019, 2021 Zimmer Biomet



Legal Manufacturer
Biomet Trauma
56 East Bell Drive
P.O. Box 587
Warsaw, Indiana 46581
USA

CE2797